

SCALE 1:5,000
0 100 200 300m

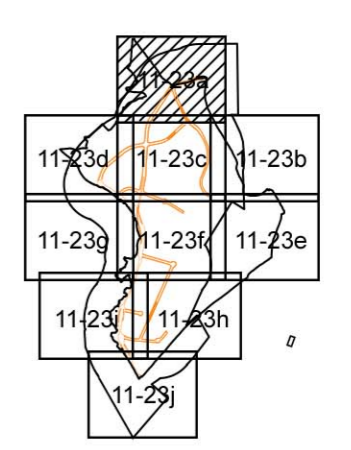

KEYPLAN

- LEGEND**
- 500m Assessment Area Boundary
 - - - Project Boundary
 - - - DP1
 - - - DP2
 - - - DP5
 - - - DP6
 - - - DP12

- LCA1** MISCELLANEOUS RURAL FRINGE LANDSCAPE = 413986 SQM
- LCA2** MISCELLANEOUS URBAN FRINGE LANDSCAPE = 70215 SQM
- LCA3** RESIDENTIAL URBAN LANDSCAPE = 770 SQM
- LCA4** UPLAND AND HILLSIDE LANDSCAPE = 4938 SQM
- LCA6** RURAL COASTAL PLAIN LANDSCAPE = 4849 SQM



Agreement No. CE 2/2011 (CE)
Hung Shui Kiu New Development Area Planning and Engineering Study - Investigation
Landscape Character Area Impacts Enlargement Plan 01

SCALE	1:5,000@A3	DATE	AUG 2016
CHECK	AM	DRAWN	PN
JOB No.	60222570	FIGURE	11.23a
		REV	

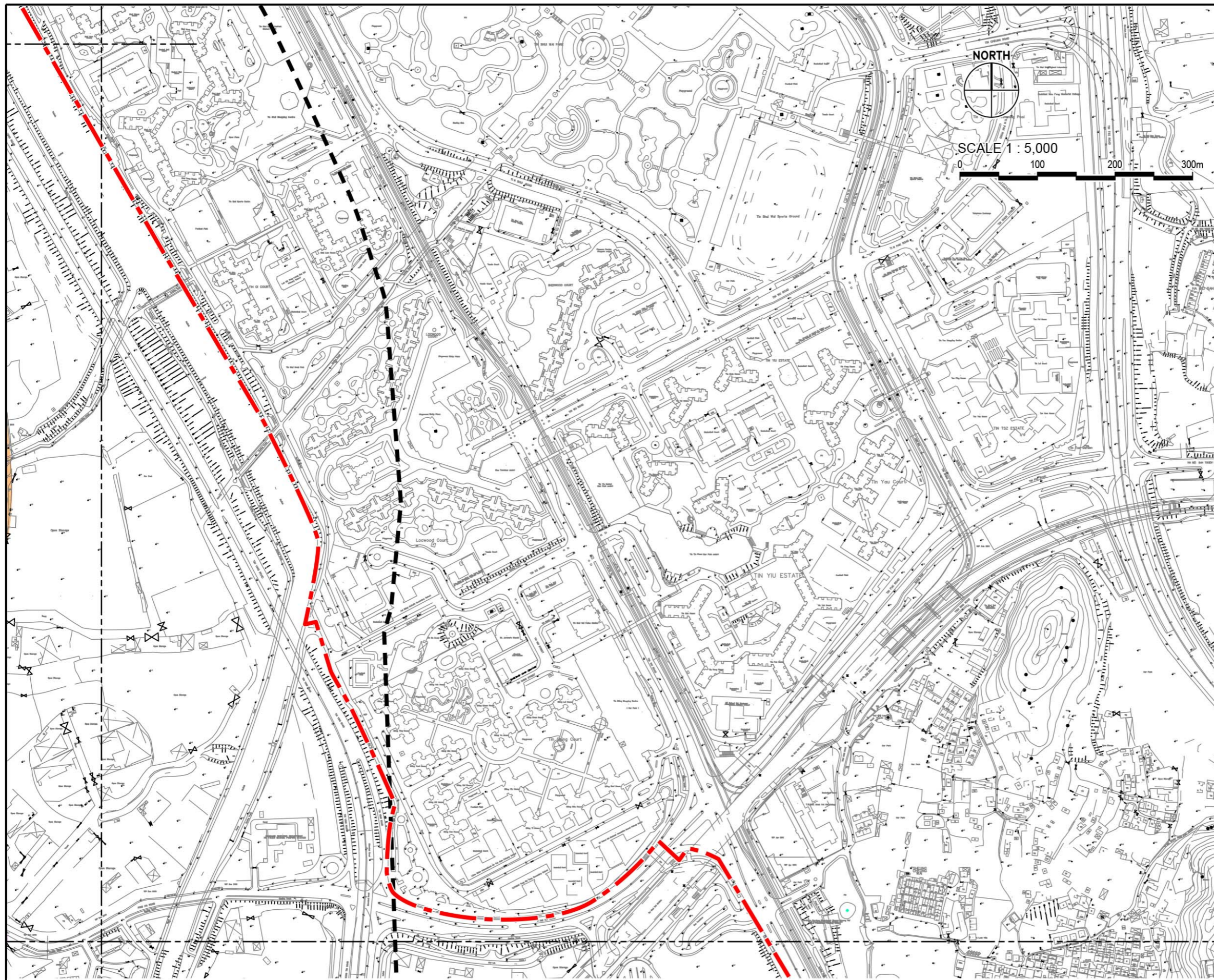

SCALE 1 : 5,000

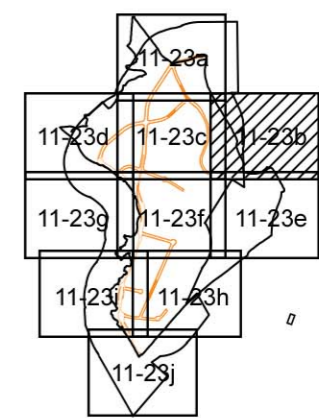

KEYPLAN

LEGEND

- 500m Assessment Area Boundary
- Project Boundary
- DP1
- DP2
- DP5
- DP6
- DP12

- LCA1** MISCELLANEOUS RURAL FRINGE LANDSCAPE = 413986 SQM
- LCA2** MISCELLANEOUS URBAN FRINGE LANDSCAPE = 70215 SQM
- LCA3** RESIDENTIAL URBAN LANDSCAPE = 770 SQM
- LCA4** UPLAND AND HILLSIDE LANDSCAPE = 4938 SQM
- LCA6** RURAL COASTAL PLAIN LANDSCAPE = 4849 SQM



Agreement No. CE 2/2011 (CE)
 Hung Shui Kiu New Development Area Planning and Engineering Study - Investigation
Landscape Character Area Impacts Enlargement Plan 02

SCALE	1:5,000@A3	DATE	AUG 2016
CHECK	AM	DRAWN	PN
JOB No.	60222570	FIGURE	11.23b
		REV	

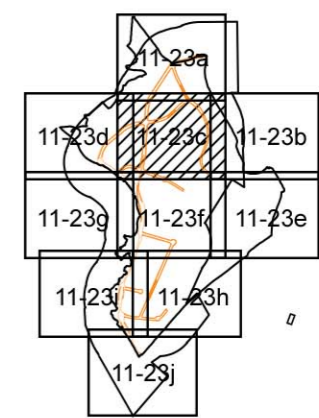
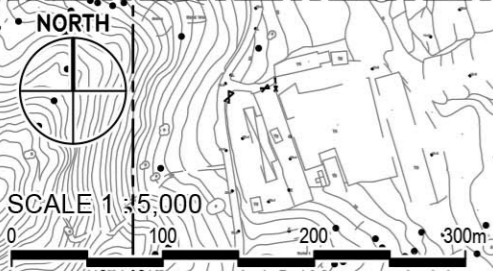
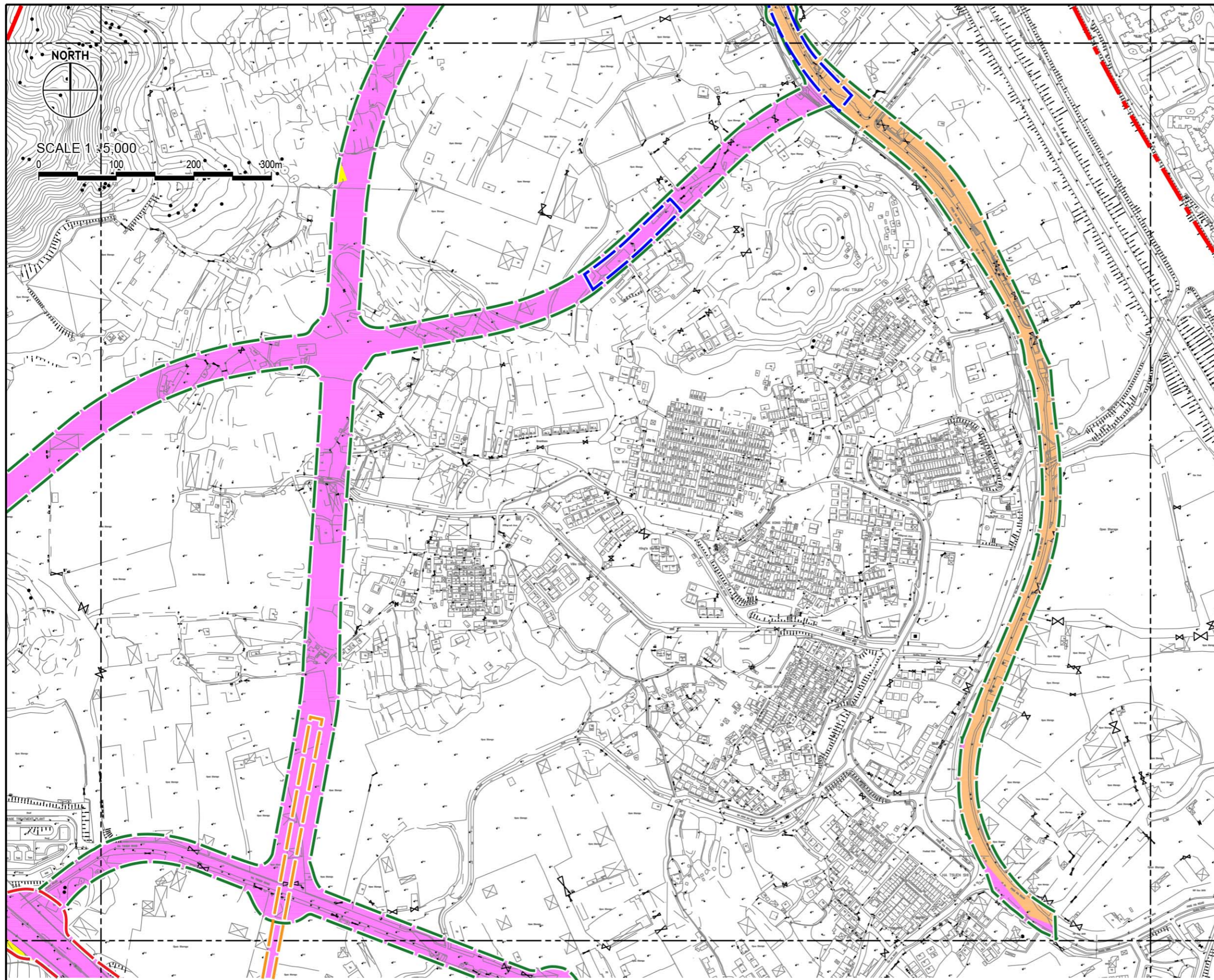

KEYPLAN

- LEGEND**
- 500m Assessment Area Boundary
 - Project Boundary
 - DP1
 - DP2
 - DP5
 - DP6
 - DP12

- LCA1** MISCELLANEOUS RURAL FRINGE LANDSCAPE = 413986 SQM
- LCA2** MISCELLANEOUS URBAN FRINGE LANDSCAPE = 70215 SQM
- LCA3** RESIDENTIAL URBAN LANDSCAPE = 770 SQM
- LCA4** UPLAND AND HILLSIDE LANDSCAPE = 4938 SQM
- LCA6** RURAL COASTAL PLAIN LANDSCAPE = 4849 SQM



Agreement No. CE 2/2011 (CE)
 Hung Shui Kiu New Development Area Planning and Engineering Study - Investigation
Landscape Character Area Impacts Enlargement Plan 03

SCALE	1:5,000@A3	DATE	AUG 2016
CHECK	AM	DRAWN	PN
JOB No.	60222570	FIGURE	11.23c
		REV	

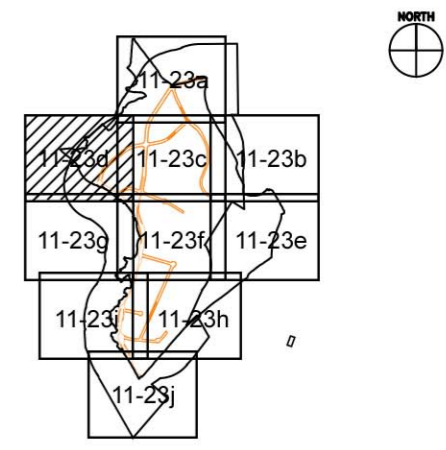
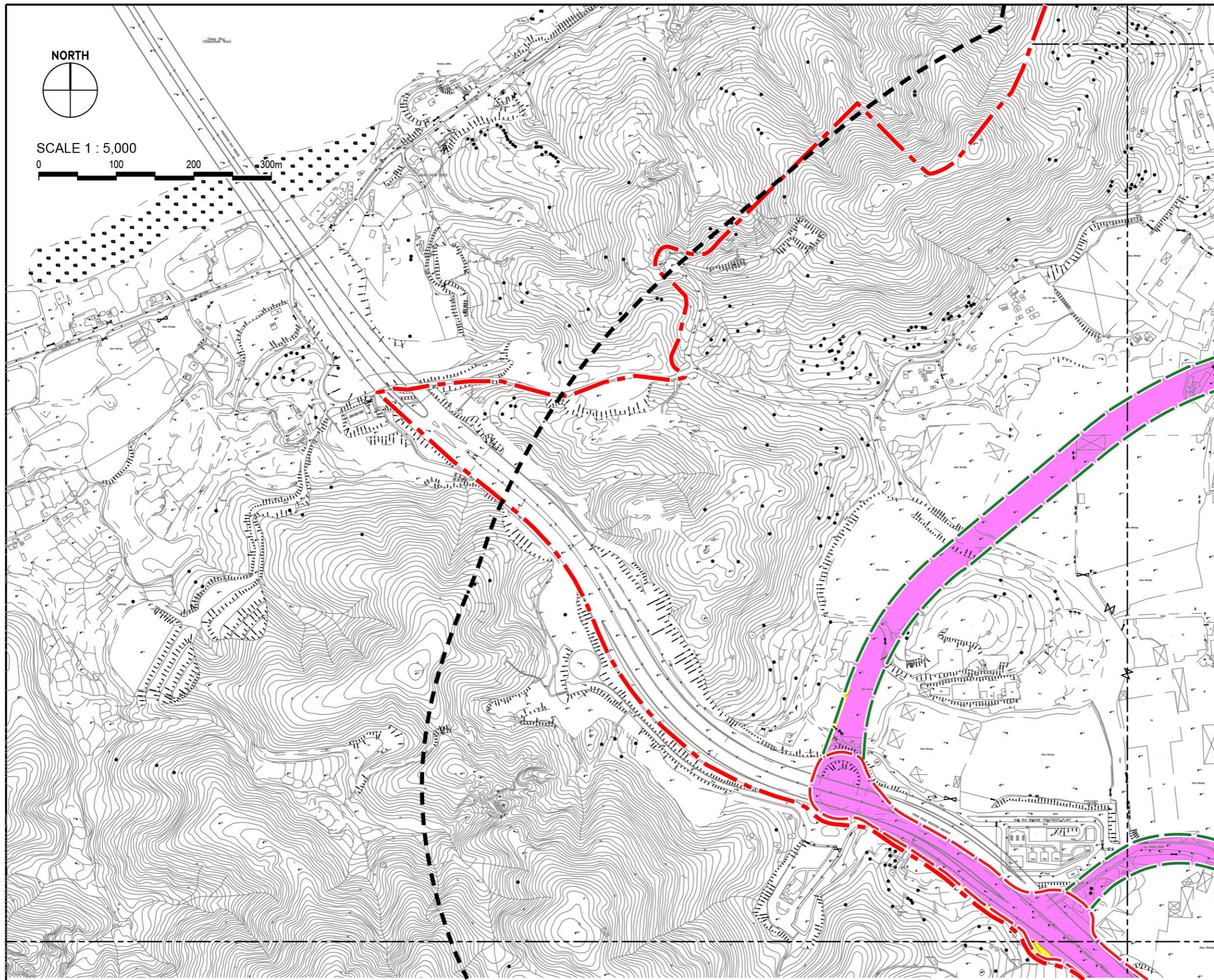

KEYPLAN

- LEGEND**
- 500m Assessment Area Boundary
 - - - Project Boundary
 - - - DP1
 - - - DP2
 - - - DP5
 - - - DP6
 - - - DP12

- LCA1** MISCELLANEOUS RURAL FRINGE LANDSCAPE = 413986 SQM
- LCA2** MISCELLANEOUS URBAN FRINGE LANDSCAPE = 70215 SQM
- LCA3** RESIDENTIAL URBAN LANDSCAPE = 770 SQM
- LCA4** UPLAND AND HILLSIDE LANDSCAPE = 4938 SQM
- LCA6** RURAL COASTAL PLAIN LANDSCAPE = 4849 SQM



Agreement No. CE 2/2011 (CE)
 Hung Shui Kiu New Development Area Planning and Engineering Study - Investigation
Landscape Character Area Impacts Enlargement Plan 04

SCALE	1:5,000@A3	DATE	AUG 2016
CHECK	AM	DRAWN	PN
JOB No.	60222570	FIGURE	11.23d
		REV	

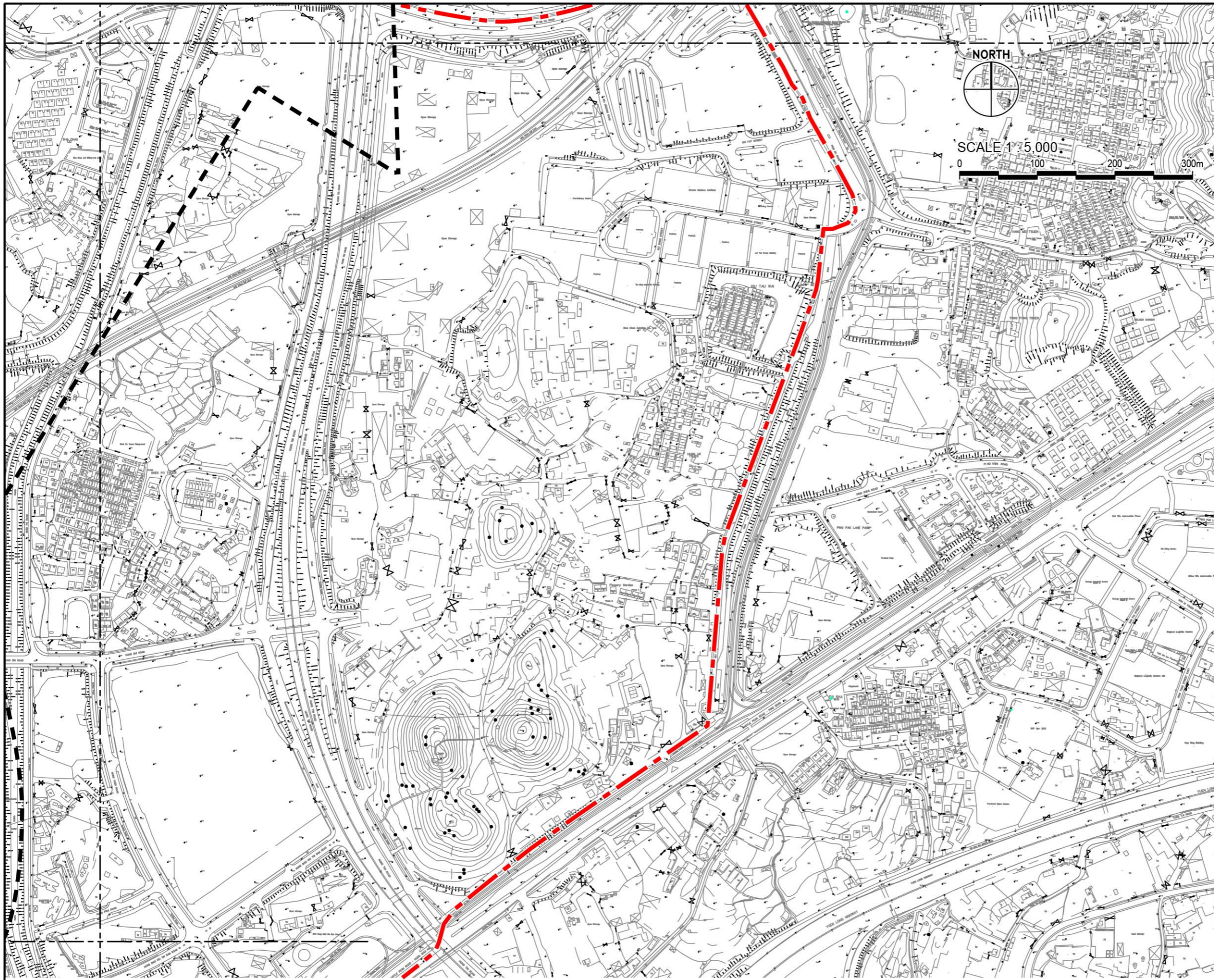

SCALE 1:5,000
0 100 200 300m

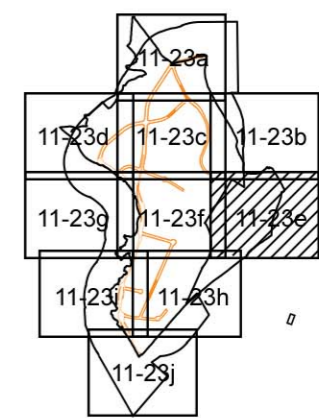

KEYPLAN

- LEGEND**
- 500m Assessment Area Boundary
 - Project Boundary
 - DP1
 - DP2
 - DP5
 - DP6
 - DP12

- LCA1** MISCELLANEOUS RURAL FRINGE LANDSCAPE = 413986 SQM
- LCA2** MISCELLANEOUS URBAN FRINGE LANDSCAPE = 70215 SQM
- LCA3** RESIDENTIAL URBAN LANDSCAPE = 770 SQM
- LCA4** UPLAND AND HILLSIDE LANDSCAPE = 4938 SQM
- LCA6** RURAL COASTAL PLAIN LANDSCAPE = 4849 SQM



Agreement No. CE 2/2011 (CE)
Hung Shui Kiu New Development Area Planning and Engineering Study - Investigation
Landscape Character Area Impacts Enlargement Plan 05

SCALE	1:5,000@A3	DATE	AUG 2016
CHECK	AM	DRAWN	PN
JOB No.	60222570	FIGURE	11.23e
		REV	

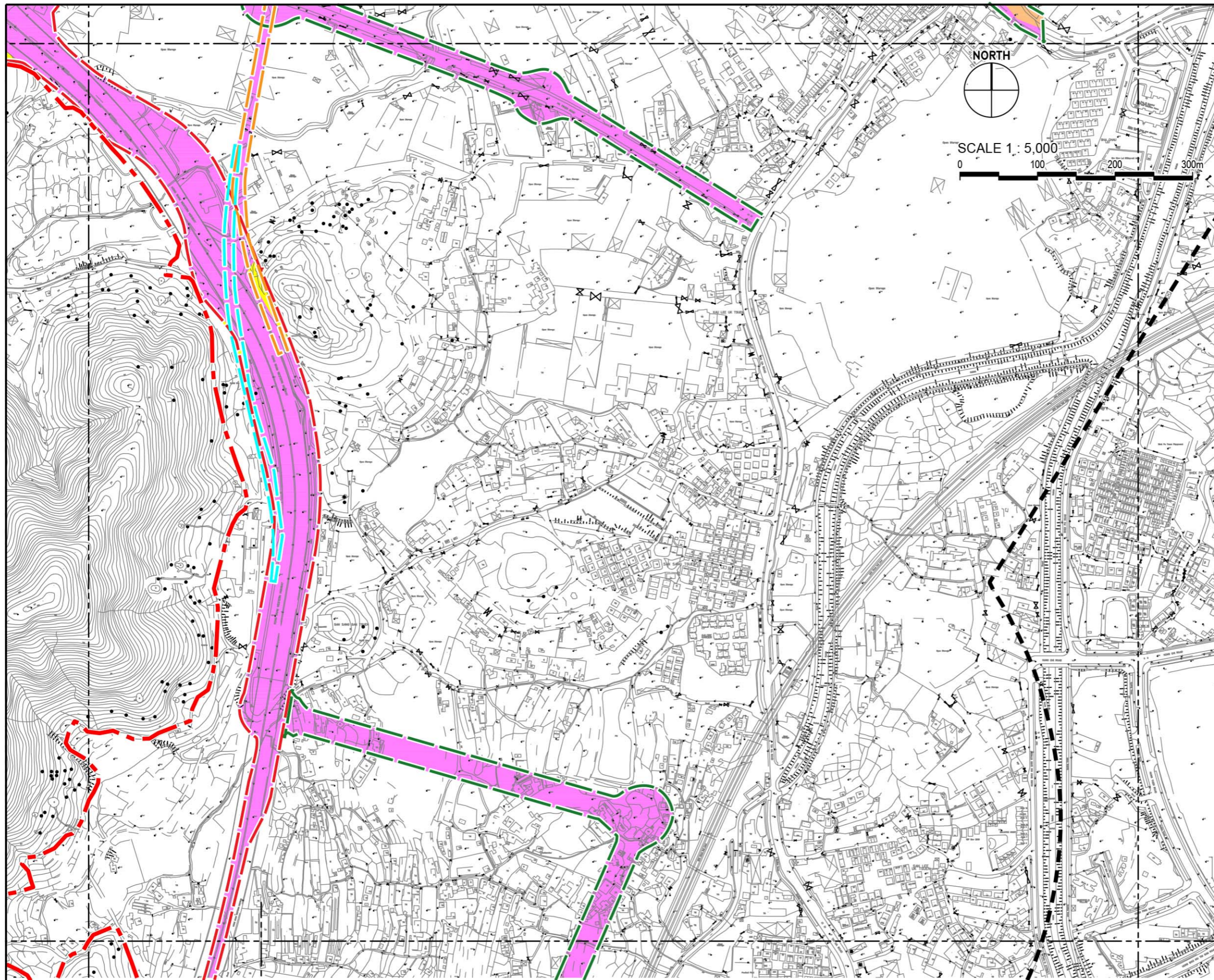

SCALE 1 : 5,000
0 100 200 300m

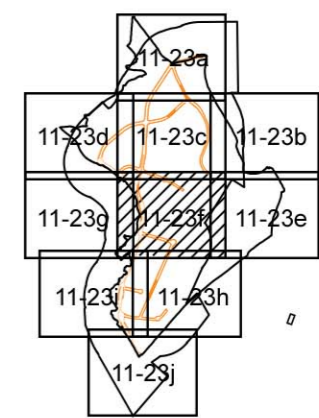

KEYPLAN

- LEGEND**
- 500m Assessment Area Boundary
 - Project Boundary
 - DP1
 - DP2
 - DP5
 - DP6
 - DP12

- LCA1** MISCELLANEOUS RURAL FRINGE LANDSCAPE = 413986 SQM
- LCA2** MISCELLANEOUS URBAN FRINGE LANDSCAPE = 70215 SQM
- LCA3** RESIDENTIAL URBAN LANDSCAPE = 770 SQM
- LCA4** UPLAND AND HILLSIDE LANDSCAPE = 4938 SQM
- LCA6** RURAL COASTAL PLAIN LANDSCAPE = 4849 SQM



Agreement No. CE 2/2011 (CE)
Hung Shui Kiu New Development Area Planning and Engineering Study - Investigation
Landscape Character Area Impacts Enlargement Plan 06

SCALE	1:5,000@A3	DATE	AUG 2016
CHECK	AM	DRAWN	PN
JOB No.	60222570	FIGURE 11.23f	REV

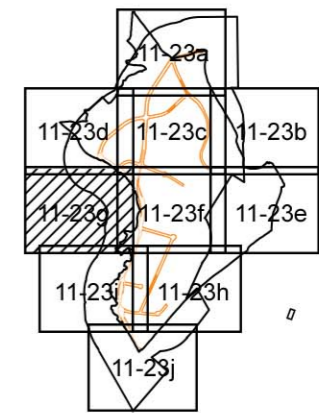
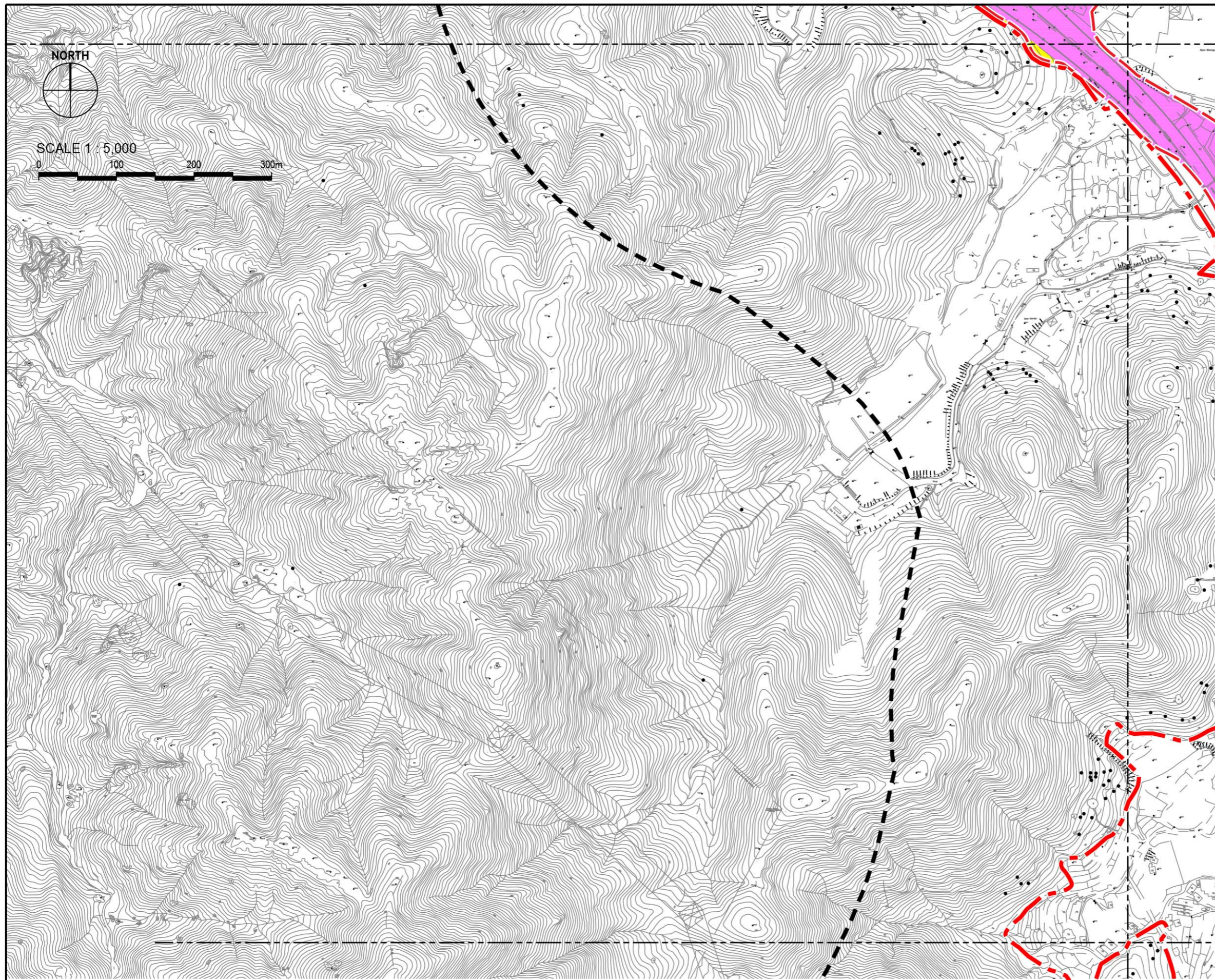

KEYPLAN

LEGEND

- 500m Assessment Area Boundary
- Project Boundary
- DP1
- DP2
- DP5
- DP6
- DP12

- LCA1** MISCELLANEOUS RURAL FRINGE LANDSCAPE = 413986 SQM
- LCA2** MISCELLANEOUS URBAN FRINGE LANDSCAPE = 70215 SQM
- LCA3** RESIDENTIAL URBAN LANDSCAPE = 770 SQM
- LCA4** UPLAND AND HILLSIDE LANDSCAPE = 4938 SQM
- LCA6** RURAL COASTAL PLAIN LANDSCAPE = 4849 SQM



Agreement No. CE 2/2011 (CE)
 Hung Shui Kiu New Development Area Planning and Engineering Study - Investigation
Landscape Character Area Impacts Enlargement Plan 07

SCALE	1:5,000@A3	DATE	AUG 2016
CHECK	AM	DRAWN	PN
JOB No.	60222570	FIGURE	11.23g
		REV	

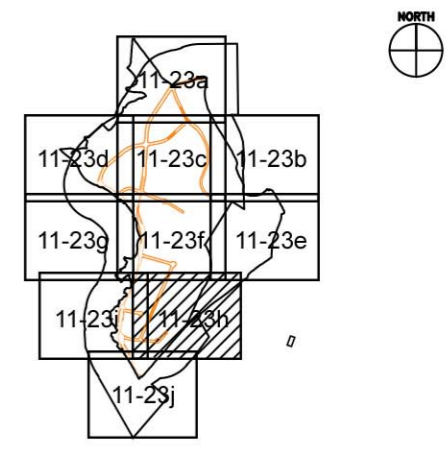
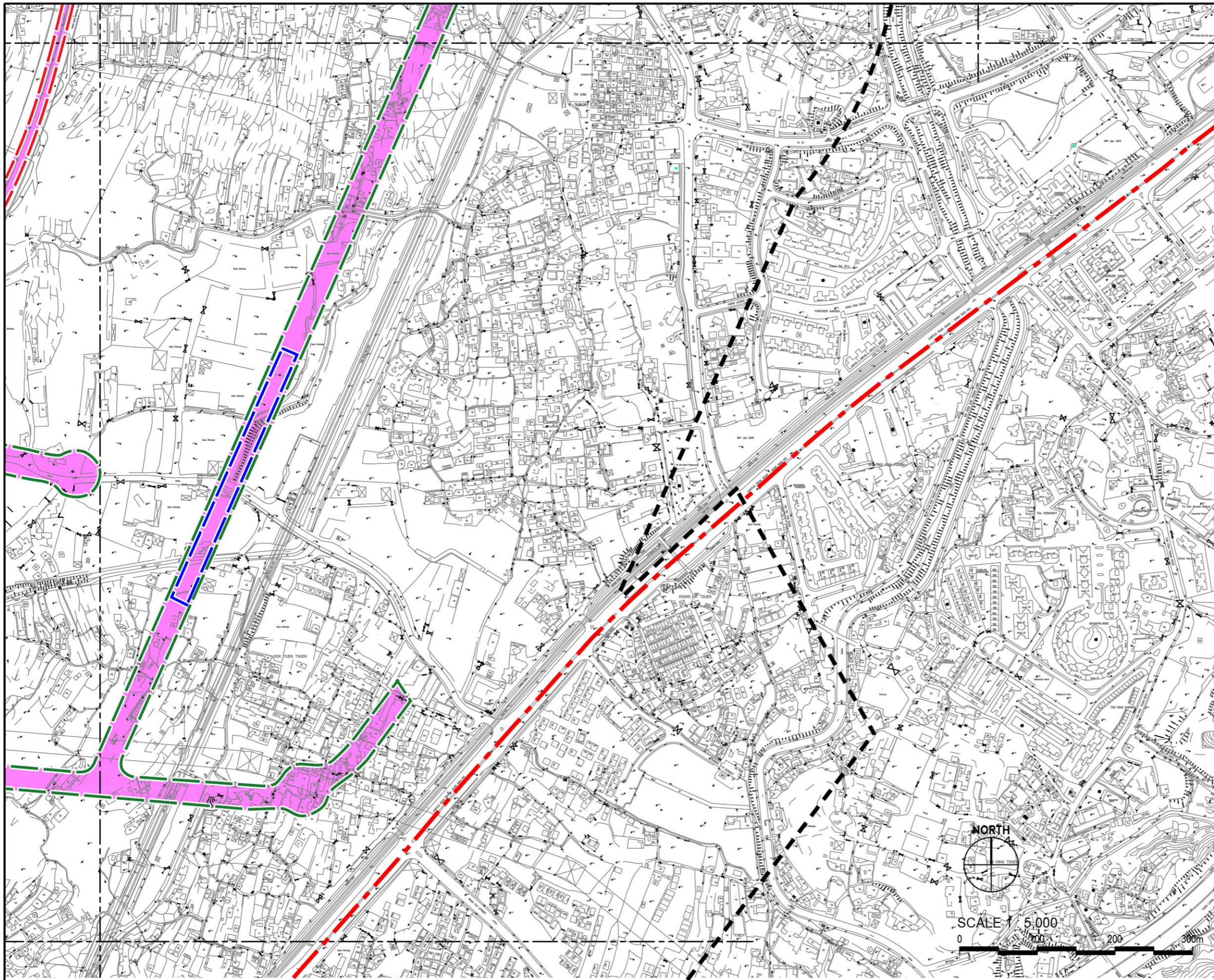

KEYPLAN

- LEGEND**
- 500m Assessment Area Boundary
 - - - Project Boundary
 - - - DP1
 - - - DP2
 - - - DP5
 - - - DP6
 - - - DP12

- LCA1** MISCELLANEOUS RURAL FRINGE LANDSCAPE = 413986 SQM
- LCA2** MISCELLANEOUS URBAN FRINGE LANDSCAPE = 70215 SQM
- LCA3** RESIDENTIAL URBAN LANDSCAPE = 770 SQM
- LCA4** UPLAND AND HILLSIDE LANDSCAPE = 4938 SQM
- LCA6** RURAL COASTAL PLAIN LANDSCAPE = 4849 SQM



Agreement No. CE 2/2011 (CE)
 Hung Shui Kiu New Development Area Planning and Engineering Study - Investigation
Landscape Character Area Impacts Enlargement Plan 08

SCALE	1:5,000@A3	DATE	AUG 2016
CHECK	AM	DRAWN	PN
JOB No.	60222570	FIGURE	11.23h
		REV	

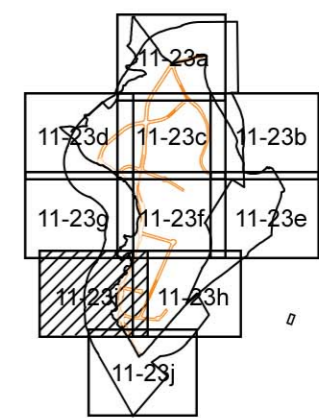
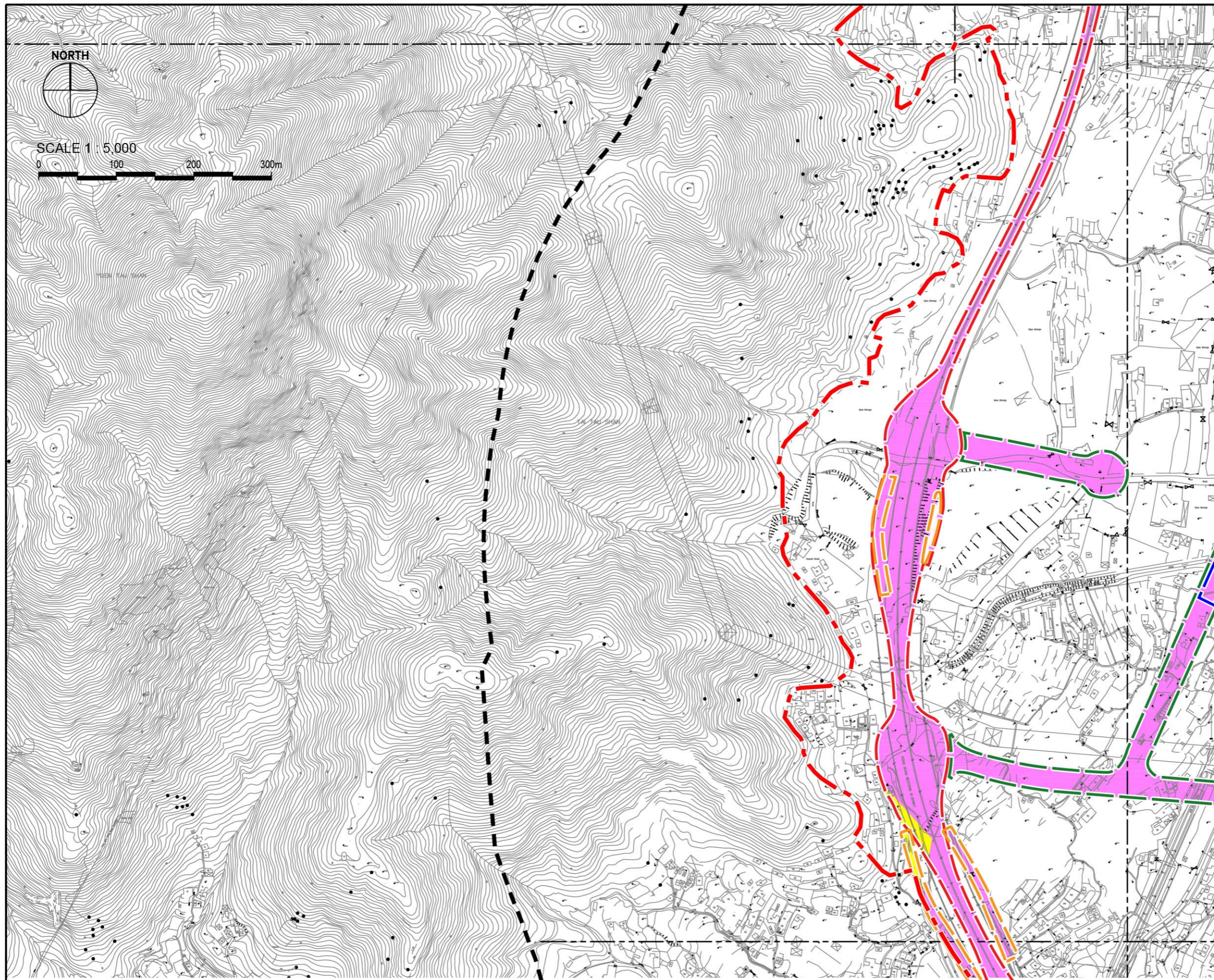

KEYPLAN

- LEGEND**
- 500m Assessment Area Boundary
 - - - Project Boundary
 - - - DP1
 - - - DP2
 - - - DP5
 - - - DP6
 - - - DP12

- LCA1** MISCELLANEOUS RURAL FRINGE LANDSCAPE = 413986 SQM
- LCA2** MISCELLANEOUS URBAN FRINGE LANDSCAPE = 70215 SQM
- LCA3** RESIDENTIAL URBAN LANDSCAPE = 770 SQM
- LCA4** UPLAND AND HILLSIDE LANDSCAPE = 4938 SQM
- LCA6** RURAL COASTAL PLAIN LANDSCAPE = 4849 SQM



Agreement No. CE 2/2011 (CE)
 Hung Shui Kiu New Development Area Planning and Engineering Study - Investigation
Landscape Character Area Impacts Enlargement Plan 09

SCALE	1:5,000@A3	DATE	AUG 2016
CHECK	AM	DRAWN	PN
JOB No.	60222570	FIGURE	11.23i
		REV	

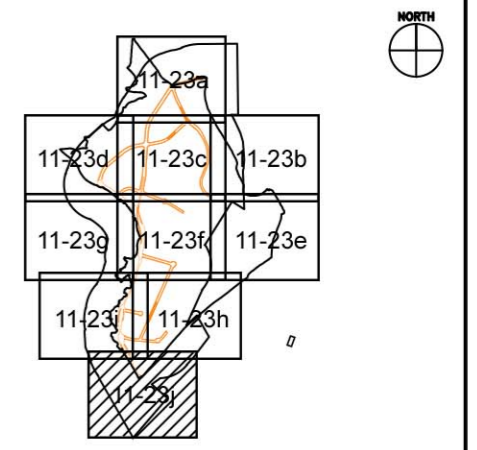
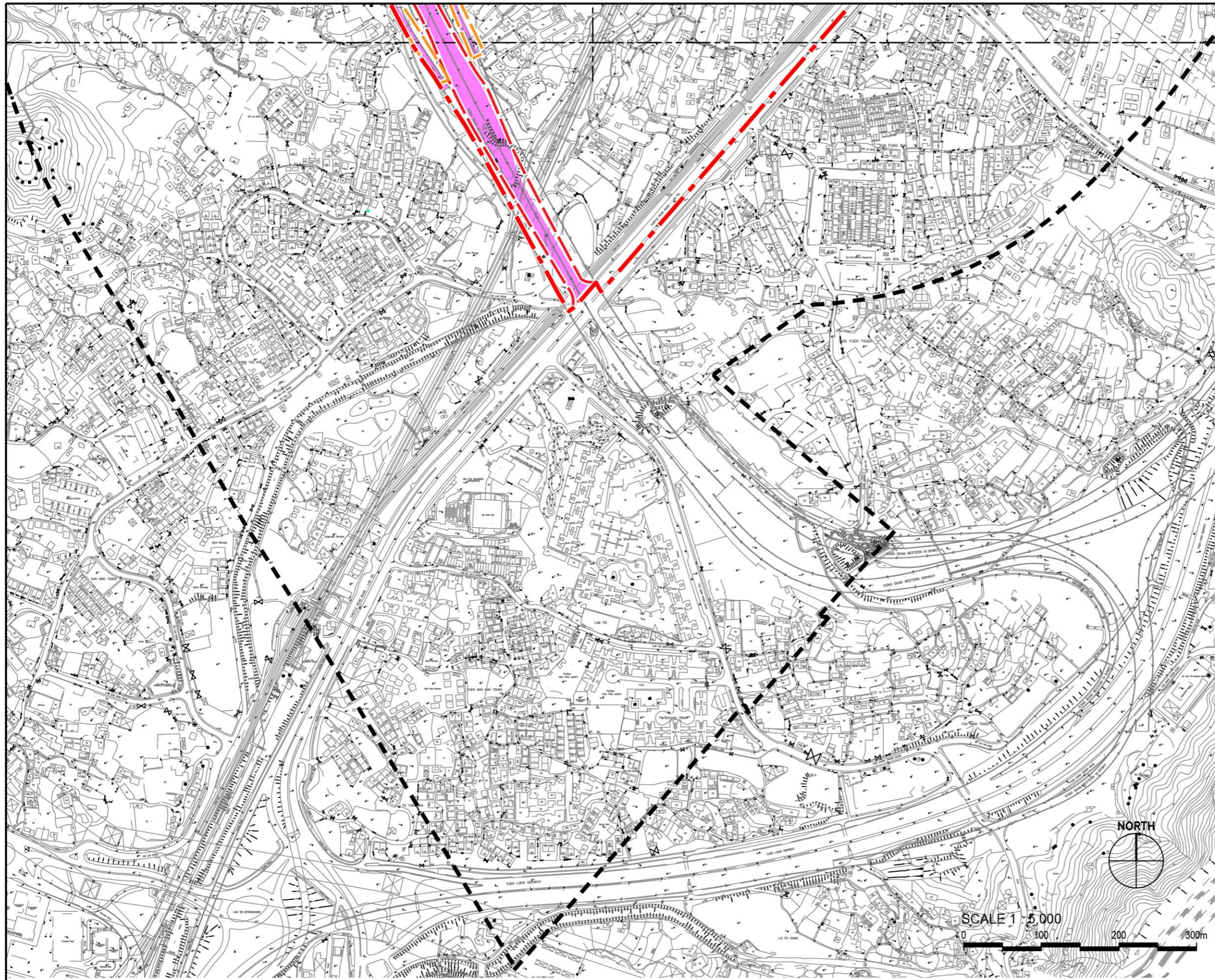

KEYPLAN

- LEGEND**
- 500m Assessment Area Boundary
 - - - - Project Boundary
 - - - - DP1
 - - - - DP2
 - - - - DP5
 - - - - DP6
 - - - - DP12

- LCA1** MISCELLANEOUS RURAL FRINGE LANDSCAPE = 413986 SQM
- LCA2** MISCELLANEOUS URBAN FRINGE LANDSCAPE = 70215 SQM
- LCA3** RESIDENTIAL URBAN LANDSCAPE = 770 SQM
- LCA4** UPLAND AND HILLSIDE LANDSCAPE = 4938 SQM
- LCA6** RURAL COASTAL PLAIN LANDSCAPE = 4849 SQM

SCALE 1:5,000
0 100 200 300m



Agreement No. CE 2/2011 (CE)
Hung Shui Kiu New Development Area Planning and Engineering Study - Investigation
Landscape Character Area Impacts Enlargement Plan 10

SCALE	1:5,000@A3	DATE	AUG 2016
CHECK	AM	DRAWN	PN
JOB No.	60222570	FIGURE 11.23j	REV