

MTR Corporation Limited

South Island Line (East)

Monthly EM&A Report No. 9

April 2012

Verified by:

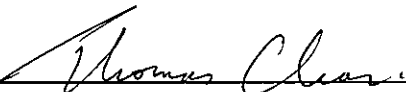
  
\_\_\_\_\_

Thomas Chan

Independent Environmental Checker

Date:

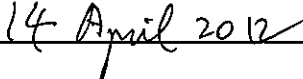
  
\_\_\_\_\_

MTR Corporation Limited

South Island Line (East)

Monthly EM&A Report No. 9

April 2012

Certified by:

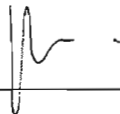

Richard Kwan

Environmental Team Leader

Date:

14 April, 2012

## ***EXECUTIVE SUMMARY***

With the main civil works contracts of the South Island Line (East) (SIL(E)) Project awarded in May 2011, the commencement date of construction of the Project was on 25 June 2011. The Environmental Monitoring and Audit (EM&A) programme of the Project also commenced on 25 June 2011. This is the ninth Monthly EM&A Report for SIL(E) Project. The Report presents the results of EM&A works undertaken during the period of 1 March 2012 to 31 March 2012. The major construction activities in the reporting period included piling, excavation and slope stabilization works as well as blasting works at WCH depot site.

Impact monitoring for air quality and noise were conducted in the reporting period. No exceedance was found and there was no breach of Action / Limit Levels for air quality and noise. Impact water quality monitoring was undertaken at Aberdeen Channel in the reporting period. Exceedances in DO against Action/ Limit Levels were recorded and the exceedances were considered not related to the project works.

Three noise complaints were referred by EPD in March 2012. All complaint investigations have been carried out in accordance with the EM&A Manual and investigation reports have been sent to EPD. No notification of summon or prosecution related to the environmental issue was received in the reporting period.

Regular site inspections were conducted by the Environmental Team (ET) to check the implementation of environmental mitigation measures. No non-conformance to the environmental requirements was identified in the reporting period.

Future key issues envisaged in the coming month include noise and dust emission from site works. The ET will continue the implementation of the EM&A programme in accordance to the EM&A Manual.

## **EXECUTIVE SUMMARY**

- 1 INTRODUCTION**
  - 1.1 Project Background**
  - 1.2 Project Programme**
  - 1.3 Coverage of the EM&A Report**
- 2 PROJECT INFORMATION**
  - 2.1 Project Organization and Management Structure**
  - 2.2 Construction Activities in the Reporting Month**
  - 2.3 Construction Activities for the Coming Month**
  - 2.4 Project Areas and Environmental Monitoring Locations**
  - 2.5 Summary of EM&A Requirements**
- 3 IMPACT MONITORING**
  - 3.1 Air Quality**
  - 3.2 Noise**
  - 3.3 Water Quality**
  - 3.4 Action taken in Event of Exceedence**
- 4 LANDSCAPE AND VISUAL**
  - 4.1 EM&A Requirements**
  - 4.2 Site Audit Results**
- 5 ECOLOGY**
  - 5.1 EM&A Requirements**
  - 5.2 Site Audit Results**
- 6 WASTE MANAGEMENT**
- 7 RECORD OF ENVIRONMENTAL COMPLAINTS**
- 8 RECORD OF NON- COMPLIANCES**
- 9 RECORD OF NOTIFICATION OF SUMMONS AND SUCCESSFUL PROSECUTIONS**
- 10 STATUS OF STATUTORY SUBMISSIONS**
  - 10.1 Submissions required under Environmental Permit**
  - 10.2 Statutory Permits and Licenses**
- 11 SITE INSPECTIONS**
  - 11.1 Implementation of Environmental Mitigation Measures**
  - 11.2 Observations**
  - 11.3 Solid and Liquid Waste Management Status**
  - 11.4 Other Notable Events**
- 12 FUTURE KEY ISSUES**
- 13 CONCLUSIONS**

### **List of Figures**

Figures 1 to 2 Works Areas of the Project

Figures 3 to 6 Location of Construction Air Quality Monitoring Stations

Figures 7 to 8 Location of Construction Noise Monitoring Stations

Figures 9 Location of Water Quality Monitoring Stations

**List of Appendices**

Appendix A1 *Project Organization*

Appendix A2 *Contact List of Key Personnel of the Project*

Appendix B1 *Action and Limit Levels for Construction Noise and Air Quality*

Appendix B2 *Action and Limit Levels for Water Quality*

Appendix C *Calibration Details*

Appendix D Graphical Plots of Air Quality, Noise & Water Quality Impact Monitoring and Monitoring Results for Water Quality

Appendix E Review of Exceedance in Water Quality Monitoring

## **1 INTRODUCTION**

### **1.1 Project Background**

The South Island Line (East) (SIL(E)) of 7.0km approximately is a new medium capacity railway with stations at South Horizons (SOH), Lei Tung (LET), Wong Chuk Hang (WCH), Ocean Park (OCP) and Admiralty (ADM), comprising underground and elevated structures. A depot is required at Wong Chuk Hang to provide maintenance support for the SIL(E).

### **1.2 Project Programme**

Main civil works contracts of the SIL(E) was awarded in May 2011. The commencement date of construction of the Project was on 25 June 2011. The construction of the Project is expected to complete in 2015.

### **1.3 Coverage of EM&A Report**

The Environmental Monitoring and Audit (EM&A) programme of the Project commenced on 25 June 2011. This is the ninth Monthly Environmental Monitoring and Audit (EM&A) Report for the Project. The Report presents the results of EM&A undertaken during the period of 1 to 31 March 2012.

## **2 PROJECT INFORMATION**

### **2.1 Project Organization and Management Structure**

The project organization is shown in **Appendix A1**. Contacts of key personnel of the Project are shown in **Appendix A2**.

### **2.2 Construction Activities in the Reporting Month**

Major construction activities carried out by the respective SIL(E) civil works contractors during the reporting period include:

#### **Contract No. 901**

<b>Site</b>	<b>Construction Activities</b>
Harcourt Garden	<ul style="list-style-type: none"><li>- ISL/TWL cofferdam</li><li>- Secant piles, diaphragm wall and plunge columns works</li><li>- Construction of site office</li><li>- Construction of capping beam</li><li>- Excavate and install 2nd and 3rd level of walings and struts</li><li>- Excavation and ELS for SEE Shaft</li><li>- Covered walkway at Harcourt Road</li></ul>

**Contract No. 902**

Site	Construction Activities
Hong Kong Park Ventilation Shaft	<ul style="list-style-type: none"> <li>- Construction for plant room</li> <li>- Utility diversion</li> <li>- Temporary traffic arrangement</li> <li>- Provision of temporary RCP and DG stores to LCSD</li> </ul>
Nam Fung Portal	<ul style="list-style-type: none"> <li>- Temporary haul road construction</li> <li>- Pile cap excavation and construction</li> <li>- Pier construction</li> <li>- Drilling and grouting works for soft ground tunnel</li> <li>- ELS works (Shaft portion)</li> <li>- Erection of site hoarding and noise barrier</li> <li>- Relocation of temporary site office</li> <li>- Trenches for Town Gas and installation of dewatering wells at Nam Fung Road</li> </ul>
Chung Hom Shan Magazine	<ul style="list-style-type: none"> <li>- FSD / Police / Mines inspections completed</li> <li>- Operation of Magazine</li> </ul>
Telegraph Bay Barging Point	<ul style="list-style-type: none"> <li>- Site preparation</li> <li>- Construction of the barging ramp footings and structural steel works</li> <li>- Construction of noise enclosure</li> </ul>

**Contract No. 903**

Site	Construction Activities
OCP Station	<ul style="list-style-type: none"> <li>- Bored piling</li> <li>- Formation / Groundwork for OCP substructure</li> <li>- Pre-bored socket H piling for OCP Footbridges</li> <li>- Pile caps for OCP footbridge</li> </ul>
WCH Station	<ul style="list-style-type: none"> <li>- Bored piling</li> <li>- Construction of new nullah wall</li> <li>- Construction of Station Pad Footing</li> <li>- Nullah deck construction</li> </ul>
Zone B (Ex-Canadian Site to OCP Station)	<ul style="list-style-type: none"> <li>- Pier and Cross Head construction</li> </ul>
Zone C (OCP Station to WCH Station)	<ul style="list-style-type: none"> <li>- Bored piling</li> <li>- Pile cap construction</li> <li>- Slope stabilisation</li> <li>- Hoarding erection</li> <li>- Construction of nullah wall</li> </ul>
Zone D (WCH Station to WCH nullah)	<ul style="list-style-type: none"> <li>- Gravity wall</li> <li>- Pile caps</li> <li>- Bored piling</li> </ul>
Zone E (Aberdeen Channel)	<ul style="list-style-type: none"> <li>- Pier stem</li> <li>- Bored piling</li> </ul>

**Contract No. 904**

Site	Construction Activities
Ex-Harbour Mission School	<ul style="list-style-type: none"> <li>- Pipe piling and excavation</li> <li>- Installation of ground anchor</li> <li>- Demolition of caisson wall</li> <li>- Tunnel box construction</li> <li>- Joint bay and duct back excavation outside Sham Wan Tower</li> </ul>
Lee Wing Street	<ul style="list-style-type: none"> <li>- Tunnel portal excavation</li> <li>- Blast door erection</li> <li>- Conveyor footing along Lee Nam Road</li> <li>- Drill and blast at Adit Tunnel</li> </ul>

LET Station Entrance A	<ul style="list-style-type: none"> <li>- Site clearance and formation</li> <li>- Drainage construction</li> <li>- Excavation</li> <li>- Piling works</li> </ul>
LET Station Entrance B	<ul style="list-style-type: none"> <li>- Site clearance and preparation</li> <li>- Construction of retaining wall, manhole and pipe laying</li> <li>- Formation of new bus bay</li> </ul>
South Horizons	<ul style="list-style-type: none"> <li>- Water mains diversion</li> <li>- Installation of pipe piles</li> </ul>
South Horizons Plant Building	<ul style="list-style-type: none"> <li>- Site clearance and preparation</li> <li>- Erection of safety fence</li> <li>- Haul road excavation</li> </ul>
Project site office at Ap Lei Chau Bridge Playground	<ul style="list-style-type: none"> <li>- Establishment of welfare facility</li> <li>- Operation of project site office</li> </ul>

**Contract No. 907**

Site	Construction Activities
WCH Depot	<ul style="list-style-type: none"> <li>- Site formation</li> <li>- Pipe piling</li> <li>- Blasting</li> <li>- Utility diversions</li> </ul>
Lee Nam Road Barging Facility	<ul style="list-style-type: none"> <li>- Barging facility in operation</li> </ul>

**2.3 Construction Activities for the Coming Month**

The scheduled major construction activities in the next reporting month are as follows:

**Contract No. 901**

Site	Construction Activities
Harcourt Garden	<ul style="list-style-type: none"> <li>- ISL/TWL cofferdam</li> <li>- Secant piles, diaphragm wall and plunge columns works</li> <li>- Construction of site office</li> <li>- Excavate and install 2nd and 3rd level of walings and struts</li> <li>- Excavation and ELS for SEE Shaft</li> <li>- Covered walkway at Harcourt Road</li> <li>- Temporary CITIC footbridge diversion</li> <li>- Installation of Tower Crane</li> </ul>

**Contract No. 902**

Site	Construction Activities
Hong Kong Park Ventilation Shaft	<ul style="list-style-type: none"> <li>- Construction for plant room</li> <li>- Demolition of existing RCP building</li> <li>- Utility diversion</li> <li>- Temporary traffic arrangement</li> <li>- Provision of temporary RCP and DG stores to LCSD</li> </ul>
Nam Fung Portal	<ul style="list-style-type: none"> <li>- Pile cap excavation and construction</li> <li>- Pier construction</li> <li>- Drilling and grouting works for soft ground tunnel</li> <li>- ELS works (Shaft portion)</li> <li>- Erection of site hoarding and noise barrier</li> <li>- Relocation of temporary site office</li> <li>- Trenches for Town Gas and installation of dewatering wells at Nam Fung Road</li> </ul>

Chung Hom Shan Magazine	- Operation of Magazine
Telegraph Bay Barging Point	- Site preparation - Construction of the barging ramp footings and structural steel works - Construction of noise enclosure

### Contract No. 903

Site	Construction Activities
OCP Station	- Bored piling - Formation / Groundwork for OCP substructure - Pre-bored Socket H piling for OCP footbridge - Pile cap for OCP footbridge construction
WCH Station	- Construction of station pad footings / depot bored piling - New south nullah wall excavation - Construction of Columns - Utility diversions
Zone B (Ex-Canadian Site to OCP Station)	- Pier construction - Segment erection - Pier and cross head construction
Zone C (OCP Station to WCH Station)	- Pile Cap construction - Pier / portal construction - Construction of nullah wall - Nullah deck construction - Slope stabilization - Mini piling
Zone D (WCH Station to WCH nullah)	- Bored piling - Pile caps - Gravity wall - Piers construction
Zone E (Aberdeen Channel)	- Pile cap construction - Pier construction - Bored piling - Pier Stem - Preparation for span construction

### Contract No. 904

Site	Construction Activities
Ex-Harbour Mission School	- Pipe piling and excavation - Installation of ground anchor - Demolition of caisson wall - Tunnel box construction - Joint bay and duct back excavation outside Sham Wan Tower

Lee Wing Street	- Tunnel portal excavation - Blast door erection - Conveyor footing along Lee Nam Road - Drill and blast at Adit Tunnel
LET Station Entrance A	- Site clearance and formation - Drainage construction - Excavation - Piling works
LET Station Entrance B	- Site clearance and preparation - Construction of retaining wall, manhole and pipe laying - Formation of new bus bay

South Horizons	- Water mains diversion - Installation of pipe piles
South Horizons Plant Building	- Site clearance and preparation - Erection of safety fence - Haul road excavation
Project site office at Ap Lei Chau Bridge Playground	- Operation of project site office

**Contract No. 907**

Site	Construction Activities
WCH Depot	- Site formation - Excavation of piling cap - Pipe piling - Blasting - Utilities diversions
Lee Nam Road Barging Facility	- Barging facility in operation

**2.4 Project Areas and Environmental Monitoring Locations**

The works areas of the Project are shown in **Figures 1 and 2**. The existing barging point at Telegraph Bay for the DSD's HKWDT project will be taken over and used for the SIL(E) project. Impact dust and noise monitoring will be carried out at designated monitoring locations during operation of the Telegraph Bay barging point.

The locations of environmental monitoring stations are shown in **Figures 3 to 9**. Tables 1 and 2 below shows the details of the active monitoring stations as reported in Sections 3.1 to 3.3 below.

**Table 1** Summary of impact dust and noise monitoring stations

ID	Monitoring Station
<b>Dust</b>	
CD1	Wong Chuk Hang San Wai
CD2	Police College – Police Quarters
CD3	San Wui Commercial Society of HK Chan Pak Sha School
CD4	Shan On House
CD5*	South Horizons Phase IV – Block 25
<b>Noise</b>	
CN1	San Wui Commercial Society of HK Chan Pak Sha School (Educational Institution)
CN2	Holy Spirit Seminary (Education Institution)
CN3*	Shun Fung Building (Residential)
CN4*	South Horizons Phase IV – Block 25 Dover Court (Residential)
CN5*	TWGHs Jockey Club Rehabilitation Complex Block A (Convalescent Home)

\* Location updated due to site access problem, or as per the agreement with the premises landlord, and agreed with EPD

**Table 2** Summary of impact water quality monitoring stations

ID	Location	Easting	Northing
WM1	Aberdeen West Typhoon Shelter	833953	811923
WM2	Wong Chuk Hang Nullah	834547	811966
WM3	WSD Brick Hill Seawater Intake	834896	811567
WM4	Aberdeen South Typhoon Shelter	834761	811292
CS1	Control Station	832689	811967
CS2	Control Station	834852	810689

## **2.5 Summary of EM&A Requirements**

The EM&A programme as specified in the EM&A Manual has been implemented during the construction stage.

In the reporting period, impact monitoring of LAeq, 30min noise levels was carried out at the monitoring locations as shown in Table 1 once every week. Also, 24-hour TSP monitoring was conducted at the monitoring locations as shown in Table 1 once every week. Impact water quality monitoring at Aberdeen Channel was also undertaken at the monitoring locations as shown in Table 2 three working days per week at mid-ebb and mid-flood tides.

Action and Limit Levels for construction noise and air quality as well as water quality are shown in Appendices B1 and B2 respectively. Should non-compliance of the criteria occurs, action in accordance with the respective Event and Action Plans for construction noise, air quality and water quality in the EM&A Manual / Updated EM&A Manual should be carried out.

Monthly monitoring of the ardeid night roost location beside Wong Chuk Hang Nullah by qualified ecologist was also conducted.

In addition, regular site inspection to active works areas was carried out. The areas of inspection included the pollution control and mitigation measures within the site. Waste management and landscape and visual aspects were covered.

## **3 IMPACT MONITORING**

### **3.1 Air Quality**

#### *Monitoring Methodology*

24-hour TSP samples were collected by High Volume Sampler (Graseby-Andersen) following United States Environmental Protection Agency regulations.

The sampling procedure follows to that described in the App. B of Pt 50 in 40CFR Ch.1 (U.S. Environmental Protection Agency). TSP is sampled by drawing air through a conditioned, pre-weighed filter paper inside the high volume sampler at a controlled rate. After 24-hour sampling, the filter paper with retained particles is collected and returned to the laboratory for drying in a desiccators followed by weighing. TSP levels are calculated from the ratio of the mass of particulate retained on the filter paper to the total volume of air sampled.

The samplers have been properly maintained. Prior to dust monitoring commencing, appropriate checks have been made to ensure that all equipment and necessary power supply are in good working condition.

### *Calibration Requirements*

The flow rate of the high volume sampler with mass flow controller is calibrated using an orifice calibrator. Initial calibration (five points) is conducted upon installation and prior to commissioning. Calibration will be carried out every six months. The calibration records are shown in **Appendix C**.

### *Monitoring Results*

To examine the construction dust levels, 24-hour TSP monitoring was undertaken at the monitoring locations as shown in Table 1 according to the EM&A Manual.

Monitoring results are presented in the following table (see **Appendix D** for graphical plots). The 24-hour TSP levels were within the Action Level. No exceedance was found. This indicates that the construction activities did not have a noticeable adverse effect on the general air quality of the project areas.

Date	TSP ( $\mu\text{g}/\text{m}^3$ )	Action Level ( $\mu\text{g}/\text{m}^3$ )	Limit Level ( $\mu\text{g}/\text{m}^3$ )	Compliance (Yes/No)	Weather Condition
<b>CD1 Wong Chuk Hang San Wai</b>					
06-Mar	44.5	173	260	Yes	Fine
13-Mar	76.7	173	260	Yes	Cloudy
20-Mar	76.7	173	260	Yes	Fine
27-Mar	125.0	173	260	Yes	Fine
<b>CD2 Police College – Police Quarters</b>					
06-Mar	130.9	184	260	Yes	Fine
13-Mar	178.5	184	260	Yes	Cloudy
20-Mar	144.0	184	260	Yes	Fine
27-Mar	155.3	184	260	Yes	Fine
<b>CD3 San Wui Commercial Society of HK Chan Pak Sha School</b>					
06-Mar	44.6	169	260	Yes	Fine
13-Mar	80.1	169	260	Yes	Cloudy
20-Mar	85.7	169	260	Yes	Fine
27-Mar	139.5	169	260	Yes	Fine
<b>CD4 Shan On House</b>					
01-Mar-12	35.4	176	260	Yes	Fine
07-Mar-12	32.9	176	260	Yes	Fine
14-Mar-12	41.5	176	260	Yes	Fine
20-Mar-12	70.8	176	260	Yes	Fine
28-Mar-12	69	176	260	Yes	Fine
<b>CD5 South Horizons Phase IV – Block 25</b>					
01-Mar-12	38.4	169	260	Yes	Fine
07-Mar-12	33.5	169	260	Yes	Fine
13-Mar-12	70.5	169	260	Yes	Cloudy
20-Mar-12	98.6	169	260	Yes	Fine
28-Mar-12	89.2	169	260	Yes	Fine

Note: Please refer to Figures 3 to 6 for the location of construction air quality monitoring stations

### 3.2 Noise

#### *Monitoring Methodology*

Monitoring was conducted using B&K sound analysis equipment – B&K SLM 2250. Microphone was extended 1 meter from building facades and oriented towards the works area.

#### *Calibration Requirements*

B&K 2250 sound level meters and B&K 4231 calibrators which complied with the International Electrotechnical Commission Publication 651:1979 (Type 1) and 804:1985 (Type 1), specification as referred to in the Technical Memoranda to the NCO were used for the impact monitoring. The sound level meters and calibrators are verified by the certified laboratory or manufacturer once every two years to ensure they perform to the same level of accuracy as stated in the manufacturer's specifications. The calibration records are shown in **Appendix C**.

Immediately prior to and following each set of measurements at any NSR, the accuracy of the sound level meter was checked using an acoustic calibrator generating a known sound pressure level at a known frequency. If the calibration levels before and after the measurement differs by more than 1.0dB, the measurement shall be repeated to obtain a

reliable result (note: maximum deviation during this initial baseline monitoring period was 0.3dB). Periods of prolonged or repeated overloading of the sound level meter detector were avoided by setting the meter with adequate headroom prior to commencing measurements. Measurements were recorded to the nearest 0.1 dB, with values of 0.05 being rounded up.

### *Monitoring Results*

Impact monitoring of LAeq, 30min noise levels was undertaken to measure construction noise levels in accordance with the Updated EM&A Manual at the monitoring locations as shown in Table 1. The monitoring was conducted during the course of construction works, please refer to S2.2 for major construction activities of the respective SIL(E) civil works contracts in the reporting month. Weather conditions throughout the monitoring period were mild with light wind of not exceeding 2-3m/s on average.

Monitoring results are presented in the following table (see **Appendix D** for graphical plots). No exceedance was found. It was noted that the noise levels recorded at San Wui Commercial Society of HK Chan Pak Sha School on 9, 16, 23, and 28 March 2012 were of 70.8dBA to 71.3dBA. Though this exceeded the construction noise criteria of 70dBA, this was in line with the updated prediction of noise levels as contained in the construction noise mitigation measures plan submitted under the Environmental Permit and thus complied with the Limit Level as defined in the updated EM&A Manual. No further action was taken.

Date	Time	LAeq (dBA)	Limit Level (dBA)	Compliance (Yes/No)	Weather Condition
<b>CN1 San Wui Commercial Society of HK Chan Pak Sha School</b>					
9-Mar	10:30	71.2	70#	Yes	Fine, wind <5m/s
16-Mar	15:00	71.3	70#	Yes	Fine, wind <5m/s
23-Mar	14:15	70.8	70#	Yes	Fine, wind <5m/s
28-Mar	14:50	71	70#	Yes	Fine, wind <5m/s
<b>CN2 Holy Spirit Seminary</b>					
7-Mar	16:00	70	70#	Yes	Fine, wind <5m/s
14-Mar	14:40	69.1	70#	Yes	Fine, wind <5m/s
22-Mar	16:20	68.9	70#	Yes	Fine, wind <5m/s
28-Mar	15:35	69.5	70#	Yes	Fine, wind <5m/s
<b>CN3 Shun Fung Building</b>					
1-Mar	10:30	73.6	75#	Yes	Fine, wind <5m/s
6-Mar	10:00	71.5	75#	Yes	Fine, wind <5m/s
14-Mar	11:20	72.9	75#	Yes	Fine, wind <5m/s
20-Mar	11:10	69	75#	Yes	Fine, wind <5m/s
26-Mar	10:30	72.1	75#	Yes	Fine, wind <5m/s
<b>CN4 South Horizons Phase IV – Block 25 Dover Court</b>					
7-Mar	9:00	74.4	75#	Yes	Fine, wind <5m/s
14-Mar	8:30	75.2	75#	Yes	Fine, wind <5m/s
22-Mar	13:30	74.5	75#	Yes	Fine, wind <5m/s
30-Mar	9:30	74.9	75#	Yes	Fine, wind <5m/s
<b>CN5 TWGHs Jockey Club Rehabilitation Complex Block A</b>					
7-Mar	15:20	71.2	75	Yes	Fine, wind <5m/s
16-Mar	14:15	72.8	75	Yes	Fine, wind <5m/s
22-Mar	10:35	71.4	75	Yes	Fine, wind <5m/s
27-Mar	15:10	71.2	75	Yes	Fine, wind <5m/s

Note: (#)Or updated prediction of noise levels as contained in the construction noise mitigation measures plan  
Please refer to Figures 7 to 8 for the location of construction noise monitoring stations

### 3.3 *Water Quality*

#### *Monitoring Methodology*

Water quality was monitored in terms of the following parameters: Dissolved Oxygen (DO, mg/L) and Dissolved Oxygen Saturation (DO %), temperature (°C), pH, turbidity (NTU), salinity (ppt), suspended solids (mg/L) and water depth (m). All parameters were measured in-situ whereas SS shall be determined by the laboratory.

Water samples were taken with a water sampler, consisting of a transparent PVC cylinder of 2 litres that can be effectively sealed with cups at both ends. The water sampler has a positive latch system to keep it open and prevent premature closure until released by a messenger when the sampler arrives is at the pre-determined depth.

Measurement was taken at 3 water depths, namely, 1m below water surface, mid-depth and 1m above sea bed, except where the water depth less than 6m, the mid-depth station may be omitted. Should the water depth be less than 3m, only the mid-depth station was monitored.

Duplicate in-situ measurements and samples were collected and analyzed to ensure a robust statistically interpretable dataset. Where the difference in value between the first and second measurement of DO or turbidity parameters is more than 25% of the value of the first reading, the reading was discarded and further readings were taken.

Water samples for all monitoring parameters were collected, stored, preserved and analyzed according to APHA Standard Methods. Water samples were stored in high-density polythene bottles, packed in ice and delivered to the laboratory of ETS-Testconsult Limited, a HOKLAS accredited laboratory.

The SS determination work was start within 24 hours after collection of the water samples. The SS analyses followed the standard method APHA 2540D with a detection limit of 1 mg/L as described in APHA Standard Methods for the Examination of Water and Wastewater.

A digital depth detector was employed to determine the water depth at selected stations when flows permit.

#### *Calibration Requirements*

On-site monitoring equipment namely the salinity meter, pH meter, turbidity meter, dissolved oxygen meter and temperature meter were calibrated before use. The methodologies for the calibration are referred to the instruction manual provided by the manufactures respectively. The calibration records are shown in **Appendix C**. Response of sensors and electrodes was checked with certified standard solutions before each use.

#### *Monitoring Results*

Impact water quality monitoring was undertaken in accordance with the EM&A Manual at the six designated monitoring locations at Aberdeen Channel as shown in Table 2 during the reporting period. Monitoring locations WM1-WM4 cover the Aberdeen West Typhoon Shelter, Wong Chuk Hang Nullah, WSD Brick Hill Seawater intake and Aberdeen South Typhoon Shelter while monitoring location CS1 and CS2 are the control stations. CS1 and CS2 are the upstream control stations for the Ebb and Flood tide conditions respectively.

Monitoring results and graphical plots are presented in **Appendix D**.

### **3.4 Action taken in Event of Exceedence**

There was no exceedance in air quality and noise monitoring parameters recorded in the reporting period, therefore no action was taken.

Exceedances in DO against Action/ Limit Levels were recorded at monitoring stations WM1, WM3 & WM4 on 2nd Mar 2012 in the reporting month. The exceedances were considered not related to the project works. Please refer to **Appendix E** for the review of exceedance in water quality monitoring.

## **4 LANDSCAPE AND VISUAL**

### **4.1 EM&A Requirements**

The landscape and visual mitigation measures undertaken by the contractors during the construction phase have been audited on a regular basis according to the EM&A Manual.

### **4.2 Site Audit Results**

Regular inspections and audits were conducted by the Certified Arborist as required by the EP and it was found that the transplanting works and the tree protection works being carried out by the civil works and transplantation contractors were in accordance with the EP/ EIA. No non compliance was identified in the reporting period.

#### Retained Trees

No immediate hazards were noted for any of the OVTs during reporting period.

Health conditions of the two retained and pruned trees, *Ficus elastica*, located at Wong Chuk Hang San Wai have been monitored. The contractor had enhanced the tree protection zone and was reminded to properly maintain the protection zone.

#### Transplanted Tree

Total of 419 trees of the SIL(E) had been transplanted as of the reporting month. They were mostly transplanted to the holding nursery at Chung Hom Shan and Kellett Bay, permanent receptor sites such as Lok Ma Chau or in-situ under project areas.

## **5 ECOLOGY**

### **5.1 EM&A Requirements**

Auditing of the ecological mitigation measures during the construction phase have been carried out on a regular basis according to the EM&A Manual.

### **5.2 Site Audit Results**

#### Ardeid Night Roost

Regular inspections to the works areas around the ardeid night roost have been conducted by the ecologist to check the ecological mitigation measures with regard to the ardeids at Wong Chuk Hang Nullah. Inspections of the ardeid night roost have been made for any active ardeid nests. Whilst ardeids have never been recorded nesting at this site, precautionary checks for active nests or signs of breeding have been made.

Monthly monitoring of the ardeid night roost location was also conducted by the ecologist from a vantage point, the Ap Lei Chau Bridge (on the Wong Chuk Hang side), with an unobstructed view over the area. According to the EM&A Manual, the surveys have been commenced approximately one hour before sunset and continue for 20 minutes after sunset, or until nightfall, which comes sooner. Any aggregation of night roosting ardeid in the degraded woodland or adjacent area have been located and counted.

The monthly night ardeid survey was conducted on 14 March 2012 at 5:32 p.m. A total of 303 ardeids, which included 273 Little Egrets, and 30 Great Egrets, arrived at the roost location at Wong Chuk Hang Nullah and no ardeid breeding behaviour was recorded during the monitoring survey.

Proper tree protection measures have been implemented as practical as possible by the contractor to the current and potential roost trees retained on site. However, potential risks of some of these slope trees were noted and these slope trees had been removed due to the safety concerns.

#### Plant Species of Conservation Interest

Detailed field survey led by the ecologist was undertaken in March and early May 2011 to ascertain the presence of any rare or protected flora species to be affected. The surveys covered all above ground works areas of the project and the survey results were presented in the Detailed Transplanting Baseline Survey Report submitted under the Environmental Permit.

As in the Detailed Transplanting Baseline Survey Report, two plant species of conservation interest recorded in the degraded woodland to the south of Wong Chuk Hang Nullah, namely herb *Houttuynia cordata* and tree *Aquilaria sinensis* (including seedlings), and planted young tree *Ailanthus fordii* (including seedlings) recorded in a plantation area near Hong Kong Park will be influenced by the project works. Other plant species of conservation interest identified will be protected on-site and appropriate tree protection measures would be established if needed. Health condition of the most plant species generally remained unchanged as in the Detailed Transplanting Baseline Survey Report. However, it is noted that health condition of *Ailanthus fordii* (tree no. OCP-T2231), which is outside the active works area at Wong Chuk Hang San Wai, was found to be declining. Two *Aquilaria sinensis*, which are located outside the active works area to the north of Nam Fung Road, were also found in very poor health condition and suspected to be dead specimens.

Regular monitoring on the transplanted *H. cordata*, *Ai. Fordii* has been conducted. The transplanted *H. cordata* was in fair health condition and protection fences have been maintained around the receptor sites. Condition of three specimens of *Ai Fordii* was very poor after transplantation as no new leaves or buds have regenerated, while the seedling remained in fair condition. Monitoring of these tree specimens will be continued to evaluate their potential recovery ability in the coming wet season.

The transplantation works of the two *Aq. Sinensis* had been witnessed by the certified arborist, and AFCD conducted spot inspection before and after the transplantation works. The health condition of the two transplanted *Aq. Sinensis* was fair, and a proper tree protection area had been identified. Regular monitoring will be carried out.

## 6 WASTE MANAGEMENT

Mitigation measures on waste management have been implemented in accordance with the site waste management plans for the respective civil works contracts. The C&D materials have been disposed of at the public fill reception facilities while C&D wastes have been disposed of at the landfills. Quantities of wastes disposed in the reporting period are summarized in the following table:

Contract No	Inert C&D Materials Disposed at Public Fill (m <sup>3</sup> )	Inert C&D Materials Reused (m <sup>3</sup> )	Non-inert Waste Disposed at Landfill (m <sup>3</sup> )	Chemical Waste to Designated Treatment Facility (litre)
Reporting Period: March 2012				
Contract 901	4,564	750	49	800
Contract 902	5,022	108	60	0
Contract 903	9,126	0	141	229
Contract 904	10,508	72	27	0
Contract 907	47,108	0	23	0

## 7 RECORD OF ENVIRONMENTAL COMPLAINTS

Three environmental complaints were referred from EPD in the reporting period:-

1. EPD received a public complaint on 12 March 2012. The complainant claimed that noise nuisance occurred on Sunday after the Chinese new Year 2012, and piling noise generated for whole day. Complaint investigation had been conducted and it is confirmed that there were no major construction works on Sunday with a valid CNP, and no percussive piling had been conducted for the project.

The complaint investigation report had been sent to EPD.

2. EPD received a public complaint on 21 March 2012. The complainant claimed that the percussive piling work near Block 25 of South Horizons from Monday to Saturday induced noise pollution. In addition, blasting works were suddenly conducted. The complainant further expressed that there was no noise mitigation measures on site and induced nuisance. EPD referred the complaint information to MTR on 22 March 2012 for complaint investigation as per the EM&A programme.

No percussive piling work has been involved/ will be involved for the construction of the South Horizons Station under the Project. Driving of pipe piles by drilling rigs were undertaken on site. The masts of the drilling rigs have been covered by noise shrouds. The stationary plants for supporting the construction work have been enclosed by noise fabrics. Fixed power supply distribution has been provided in the works area. Blasting works were carried out at Lee Wing Street. Blasting schedule has been provided and announced for public attention. Noise measurement was conducted and no exceedance was recorded. Regular review of the site activities will be undertaken to check the adequacy of noise mitigation measures to be implemented.

The complaint investigation report had been sent to EPD.

3. An environmental complaint regarding day time construction noise near Block 25 South Horizons was referred from EPD on 29 March 2012, which was received by EPD on 28 March 2012.

Noise mitigation measures have been implemented on site as appropriate to minimize noise nuisance to the nearby residents. Review of the site activities will be undertaken regularly to check the adequacy of noise mitigation measures to be implemented.

The complaint investigation report had been sent to EPD.

4. Regarding the complaint received on 28 February 2012, the complainant claimed about the night time works near Ocean Park. Complaint investigation had been conducted and it is confirmed that the Contractor had strictly follow the CNP requirements, and additional noise mitigation measures had been erected. No adverse comments was then received from the complainant.

The complaint investigation report had been sent to EPD.

## **8 RECORD OF NON-COMPLIANCES**

As detailed in S3.4, exceedances in water quality monitoring parameters against Action/Limit Levels were recorded in the reporting month. The exceedances were considered not related to the project works. There was no other non-compliance identified in the reporting period.

## **9 RECORD OF NOTIFICATIONS OF SUMMONS AND PROSECUTIONS**

No summon or prosecution related to environmental issue was received or made against the Project in the reporting period.

## **10 STATUS OF STATUTORY SUBMISSIONS**

### **10.1 Submissions required under Environmental Permit**

A summary of the status of submissions required under the SIL(E) Environmental Permit as of 31 March 2012 is shown below:

<b>EP Clause No.</b>	<b>Description of Submission</b>	<b>Status</b>
1.11	Commencement date of construction	Submitted on 25 May 2011
1.14	Commencement date of operation	To be submitted no later than 2 months prior to commencement of operation of the Project
2.1 & 2.2	Employment of IEC & ET	Submitted on 6 Apr 2011
2.3	Employment of Qualified Ecologist	Submitted on 6 Apr 2011
2.4	Employment of Certified Arborist	Submitted on 6 Apr 2011
2.5	Management organization of main construction companies	Submitted on 9 Jun 2011
2.6	Construction programme & EP submission schedule	Submitted on 10 Jun 2011
2.7	Set up of Community Liaison Group	Submitted on 20 Apr 2011
2.8	Updated EM&A Manual	EP Condition fulfilled dated 13 February 2012

EP Clause No.	Description of Submission	Status
2.9	Construction noise mitigation measures plan	EP Condition fulfilled dated 13 February 2012
2.11	Construction & demolition materials management plan for barging points	EP Condition fulfilled dated 12 December 2011
2.13 (a)	Ecological planting & landscape plan	EP Condition fulfilled dated 12 December 2011
2.13 (b)	As built drawings of ecological planting & landscape works	To be submitted no later than 1 month after completion of planting works (at Wong Chuk Hang nullah)
2.13 (c)	Final monitoring report of ecological planting & landscape works	To be submitted no later than 1 month after completion of the 3-year post planting care and maintenance period
2.14 (a)	Detailed transplanting baseline survey report for plant species of conservation interest	Resubmitted on 8 Sep 2011
2.14 (b)	Transplantation proposal for plant species of conservation interest	H. cordata: EP Condition fulfilled dated 15 Sep 2011 Aq. sinensis: EP Condition fulfilled dated 21 Feb 2012 Ai. fordii: EP Condition fulfilled dated 18 Oct 2011
2.14 (c)	As built drawings of transplanting works for plant species of conservation interest	H. cordata: EP Condition fulfilled dated 15 Sep 2011 Aq. sinensis: Submitted on 20 Mar 2012 Ai. fordii: EP Condition fulfilled dated 22 Dec 2011
2.15	Tree protection plan	Updated version submitted on 26 Mar 2012
2.16(a)	Silt curtain plan	For Aberdeen Channel: EP Condition fulfilled dated 12 Aug 2011 For Telegraph Bay: EP Condition fulfilled dated 14 Dec 2011
2.19	Operational groundborne noise review plan	To be submitted no later than 1 month after completion of corresponding parts of tunnel excavation
2.20	Operational groundborne noise mitigation measures plan	To be submitted no later than 1 month prior to installation of rail tracks
2.21	As built drawings for operational groundborne noise mitigation measures	To be submitted no later than 1 month after completion of tracks installation
2.23	As built drawings for operational airborne noise mitigation measures on viaduct section	To be submitted no later than 1 month after completion of noise mitigation measures installation on viaduct section
2.24	Noise performance test report	To be submitted no later than 1 month prior to commencement of operation of the Project

EP Clause No.	Description of Submission	Status
2.25	Fixed plant noise audit report	To be submitted no later than 1 month prior to commencement of operation of the Project
2.26	Visual & landscape plan	To be submitted no later than 1 month before commencement of corresponding parts of landscape works
3.3	Baseline monitoring report	EP Condition fulfilled dated 21 February 2012
3.4	Monthly EM&A reports	Submit within 2 weeks after the end of the reporting month
4.2	Internet address of EM&A and project data	Submitted on 25 Jul 2011

## 10.2 Statutory Permits and Licenses

A summary of the status of all relevant environmental permit and licenses as of 31 March 2012 is shown below:

Description	Effective Date	Expiry Date
Environmental Permit for South Island Line (East) EP-407/2010/A	14/12/2011	N/A
<b>Contract 901</b>		
Chemical Waste Producer Licence 5213-124-K3004-01	23/5/2011	N/A
Waste Disposal 7012859	1/6/2011	N/A
Water Discharge Licence WT00009466-2011	4/7/2011	30/7/2016
CNP for plunge column, secant piles, rock splitting and welding works GW-RS0272-12	12/3/2012	6/9/2012
CNP for covered walkway at Harcourt Road	Submitted on 29/2/2012	Rejected
<b>Contract 902</b>		
Chemical Waste Producer Licence 5213-175-N2206-12	24/6/2011	N/A
Chemical Waste Producer Licence 5213-124-N2345-02	28/10/2011	N/A
Waste Disposal 7012912	26/5/2011	N/A
Water Discharge Licence for HK Park WT00009688-2011	22/7/2011	30/7/2016
Water Discharge Licence for Nam Fung Path WT00009749-2011	22/7/2011	30/7/2016
Water Discharge Licence for CHS Magazine WT00009842-2011	11/8/2011	31/8/2016
Water Discharge Licence for Telegraph Bay WT00010649-2011	27/10/2011	31/10/2016
Barging Point		
CNP for Nam Fung Path GW-RS0012-12	13/01/2012	12/06/2012
<b>Contract 903</b>		
Chemical Waste Producer Licence 5213-175-L2174-31	14/6/2011	N/A
Chemical Waste Producer Licence 5213-175-L2174-32	30/6/2011	N/A
Chemical Waste Producer Licence 5213-175-L2174-33	30/6/2011	N/A
Chemical Waste Producer Licence 5213-175-L2174-34	30/6/2011	N/A
Chemical Waste Producer Licence 5213-175-L2174-35	30/6/2011	N/A
Waste Disposal 7012721	12/5/2011	N/A
Water Discharge Licence for Ap Lei Chau (ALC) Bridge WT00009838-2011	5/8/2011	31/8/2016
Water Discharge Licence for WCH Station WT00009928-2011	16/8/2011	31/8/2016
Water Discharge Licence for Zone B WT00009931-2011	16/8/2011	31/8/2016
Water Discharge Licence for OCP station WT00010501-2011	3/10/2011	31/10/2016

Description		Effective Date	Expiry Date
Water Discharge Licence for Zone D	WT00010319-2011	3/10/2011	31/10/2016
Water Discharge Licence for Zone C	WT00010648-2011	24/10/2011	31/10/2016
CNP for Zone D	GW-RS0999-11	4/11/2011	3/5/2012
CNP for Zone E	GW-RS1016-11	11/11/2011	9/5/2012
CNP for Zone E	GW-RS1191-11	30/12/2011	30/3/2012
CNP for Zone C	GW-RS0060-12	30/1/2012	24/7/2012
CNP for Zone C	GW-RS0141-12	17/2/2012	16/8/2012
CNP for TTM	GW-RS0155-12	21/2/2012	15/5/2012
CNP for OCP station	GW-RS0168-12	22/2/2012	20/8/2012
CNP for Zone C	GW-RS0194-12	29/2/2012	29/9/2012
CNP for Segment erection	GW-RS0188-12	28/2/2012	28/4/2012
CNP for Entrance A	GW-RS0248-12	9/3/2012	5/9/2012
CNP for WCH Station	GW-RS0257-12	15/3/2012	29/8/2012
<b><u>Contract 904</u></b>			
Chemical Waste Producer License for ALC Bridge Rd near Sham Wan Towers	5111-174-L2758-04	4/8/2011	N/A
Chemical Waste Producer License for ALC Bridge Rd near Harbour Mission School	5111-174-L2758-03	4/8/2011	N/A
Chemical Waste Producer License for ALC Main Street near Sunny Court	5111-174-L2758-05	4/8/2011	N/A
Chemical Waste Producer License for Lei Tung Estate Rd near Kaifong Primary School	5111-174-L2758-02	4/8/2011	N/A
Chemical Waste Producer License for Lee Nam Rd Sitting Out Area	5111-174-L2758-01	4/8/2011	N/A
Chemical Waste Producer License for Lee Nam Rd Sitting Out Area No. 2	5111-174-L2758-07	4/8/2011	N/A
Chemical Waste Producer License for Yi Nam Rd intersect with Lee Nam Rd & SOH Drive	5111-174-L2758-06	4/8/2011	N/A
Waste Disposal	7012979	25/6/2011	N/A
Water Discharge License for ALC Bridge Rd near Sham Wan Towers	WT00009781-2011	5/8/2011	31/8/2016
Water Discharge License for ALC Bridge Rd near Harbour Mission School	WT00009778-2011	5/8/2011	31/8/2016
Water Discharge License for ALC Main Street near Sunny Court	WT00009777-2011	5/8/2011	31/8/2016
Water Discharge License for Lei Tung Estate Rd near Kaifong Primary School	WT00009780-2011	5/8/2011	31/8/2016
Water Discharge License for Lee Nam Rd Sitting Out Area	WT00009779-2011	5/8/2011	31/8/2016
Water Discharge License for Lee Nam Rd Sitting Out Area No. 2	WT00009783-2011	5/8/2011	31/8/2016
Water Discharge License for Yi Nam Rd intersect with Lee Nam Rd & SOH Drive	WT00009775-2011	5/8/2011	31/8/2016
CNP for Lei Tung Estate Road opposite to Tung Hing House	GW-RS0174-12	22/2/2012	3/3/2012 (Expired)
CNP for Lee Nam Road near Horizon Plaza	GW-RS0139-12	15/2/2012	13/8/2012
CNP for Lee Nam Road near Horizon Plaza	GW-RS0201-12	1/3/2012	31/3/2012 (Expired)
CNP for Ap Lei Chau Bridge Road	GW-RS00289-12	21/3/2012	30/4/2012
CNP for Yi Nam Road near Marina Square East Centre	GW-RS0339-12	30/3/2012	27/9/2012

Description		Effective Date	Expiry Date
<b>Contract 907</b>			
Chemical Waste Producer Licence	5113-175-C3675-01	24/6/2011	N/A
Waste Disposal	7012950	31/5/2011	N/A
Waste Disposal for barges	7013400	26/8/2011	N/A
Water Discharge Licence for barging point	WT00009896-2011	11/8/2011	31/8/2016
Water Discharge Licence for WCH Depot	WT00010365-2011	21/9/2011	30/9/2016
Water Discharge Licence for bus terminus	WT00010366-2011	21/9/2011	30/9/2016
CNP for water mains	GW-RS1159-11	21/12/2011	29/2/2012
CNP for water pumping	GW-RS1168-11	30/12/2011	29/6/2012
CNP for water mains	GW-RS0093-12	3/2/2012	31/3/2012
CNP for utilities	GW-RS0296-12	29/3/2012	19/4/2012

## 11 SITE INSPECTIONS

### 11.1 Implementation of Environmental Mitigation Measures

Regular site inspections were undertaken by the ET in accordance with the EM&A Manual to check the implementation of environmental mitigation measures in the EIA. The contractors' performance on environmental matters was assessed. The environmental mitigation measures are being implemented by the civil works contractors where appropriate.

### 11.2 Observations

The findings from the site inspections and the associated recommendations on improvement to the environmental protection and pollution control works were raised to the contractors for reference and/ or action. Observations against the implementation of the mitigation measures recommended in the EP/ EIA are summarized as follows:

Item	Description	Follow up Status
<b>Contract 901</b>		
1	The contractor was reminded to provide drip trays for chemicals.	On-going
2	The contractor was reminded to enhance dust control for main haul road, demolishing works and earth moving activities.	On-going
3	The contractor was reminded to remove stagnant water.	On-going
4	The contractor was reminded to enhance the segregation of recycle materials.	On-going
5	The contractor was reminded to improve the site drainage system and divert all surface runoff to wastewater treatment system for proper treatment.	On-going
6	The contractor was reminded to operate the air compressor with all the panel door closed.	On-going

Item	Description	Follow up Status
<b>Contract 902</b>		
1	The contractor was reminded to provide drip tray during equipment maintenance works to prevent oil leakage.	Improved and standard to be maintained
2	The contractor was reminded to properly maintain the site drainage system and provide adequate silt removal facilities.	On-going
3	The contractor was reminded to properly maintain the tree protection zone.	Improved and standard to be maintained
4	The contractor was reminded to spray water to the haul road and during handling of dusty materials for dust suppression.	On-going
5	The contractor was reminded to cover stockpiling or remove them as soon as possible.	Improved and standard to be maintained
6	The contractor is reminded to provide adequate temporary noise mitigation measures.	On-going
<b>Contract 903</b>		
2	The contractor was reminded to improve housekeeping of the site.	Improved and standard to be maintained
3	The contractor was reminded to clean the nullah before the re-open of the stop log for the coming wet season. In addition, the contractor should closely monitor the effluent quality during the de-silting of the nullah.	Ongoing
4	The contractor was reminded to improve the tree protection works.	On-going
5	Water spraying system has been installed by the contractor at the WCH station area for dust suppression.	Improved and standard to be maintained
6	Acoustic fabric has been erected nearby the Holy Spirit Seminary for the noisy works. The contractor was reminded to closely monitor the effectiveness of the mitigation measures provided.	On-going
7	The Contractor was reminded to ensure all the trucks should be covered before leaving the site, and remain covered until reaching the loading point.	On-going
8	The Contractor was reminded to conduct regular monitoring and implement proper tree protection measures for the transplanted Aq. Sinensis.	On-going
<b>Contract 904</b>		
1	The contractor was reminded to provide drip trays for chemicals and remove stagnant water inside.	Improved and standard to be maintained
	The contractor was reminded to provide drip tray during equipment maintenance works to prevent oil leakage.	Improved and standard to be maintained
2	The contractor was reminded to maintain good housekeeping.	Improved and standard to be maintained
3	The contractor was reminded to provide adequate silt removal facilities, as well as properly maintain the site drainage system and discharge.	On-going
4	The contractor was reminded to improve dust suppression measures.	On-going
5	The contractor was reminded to improve wheel washing facilities.	On-going
6	The contractor was reminded to provide adequate temporary noise mitigation measures.	On-going

Item	Description	Follow up Status
	<b>Contract 907</b>	
1	The contractor was reminded to provide drip tray for chemicals.	On-going
2	The contractor was reminded to provide drip tray / tarpaulin sheet during equipment maintenance works to prevent oil leakage.	On-going
3	The contractor was reminded to provide appropriate labels for the chemical waste in the chemical waste store.	Improved and standard to be maintained
4	The contractor was reminded to maintain good housekeeping.	On-going
5	The contractor was reminded to increase the water spraying frequency within the breaking zone.	On-going
6	Special construction arrangement had been implemented during the public examination period. Rock breaking works only carried out at those areas with a certain distance apart from the school. The Contractor was reminded to keep on the practice until the end of the public examination period.	On-going

### **11.3 Solid and Liquid Waste Management Status**

Base on the findings of the site inspections, the Contractors' performance in solid and liquid waste management were acceptable and compliance with the EIA requirements were demonstrated. The current management standard should be maintained.

### **11.4 Other Notable Events**

#### IEC Site Inspections

The IEC conducted site inspections for respective works areas on 8, 21, 26 and 27 March 2012. Minor irregularities including provision of movable noise barriers as necessary and enhancing site drainage system and dust suppression measures were observed during the site inspections. Follow up actions had been taken by the respective civil works contractors.

### **12 FUTURE KEY ISSUES**

Future key issues envisaged in the coming month include noise and dust emission from site works, disposal of C&D wastes arising as well as tree protection on site. The ET will continue the implementation of the EM&A programme in accordance to the EM&A Manual.

### **13 CONCLUSIONS**

It is concluded from the environmental monitoring and audit works for the SIL(E) Project that the construction works were undertaken in an appropriately environmentally sensitive manner in the reporting period. The environmental protection and pollution control measures provided by the respective civil works contractors were generally acceptable apart from some minor irregularities which were rectified timely by the contractors.

The ET will continue the implementation of the EM&A programme in accordance to the EM&A Manual and to a level consistent with MTRCL's Corporate Sustainability Policy.

## FIGURES

Figures 1 to 2  
Works Areas of the Project

Figures 3 to 6  
Location of Construction Air Quality  
Monitoring Stations

Figures 7 to 8  
Location of Construction Noise  
Monitoring Stations

Figure 9  
Location of Water Quality Monitoring  
Stations

Figure 1 – Works Areas of the Project (1 of 2)

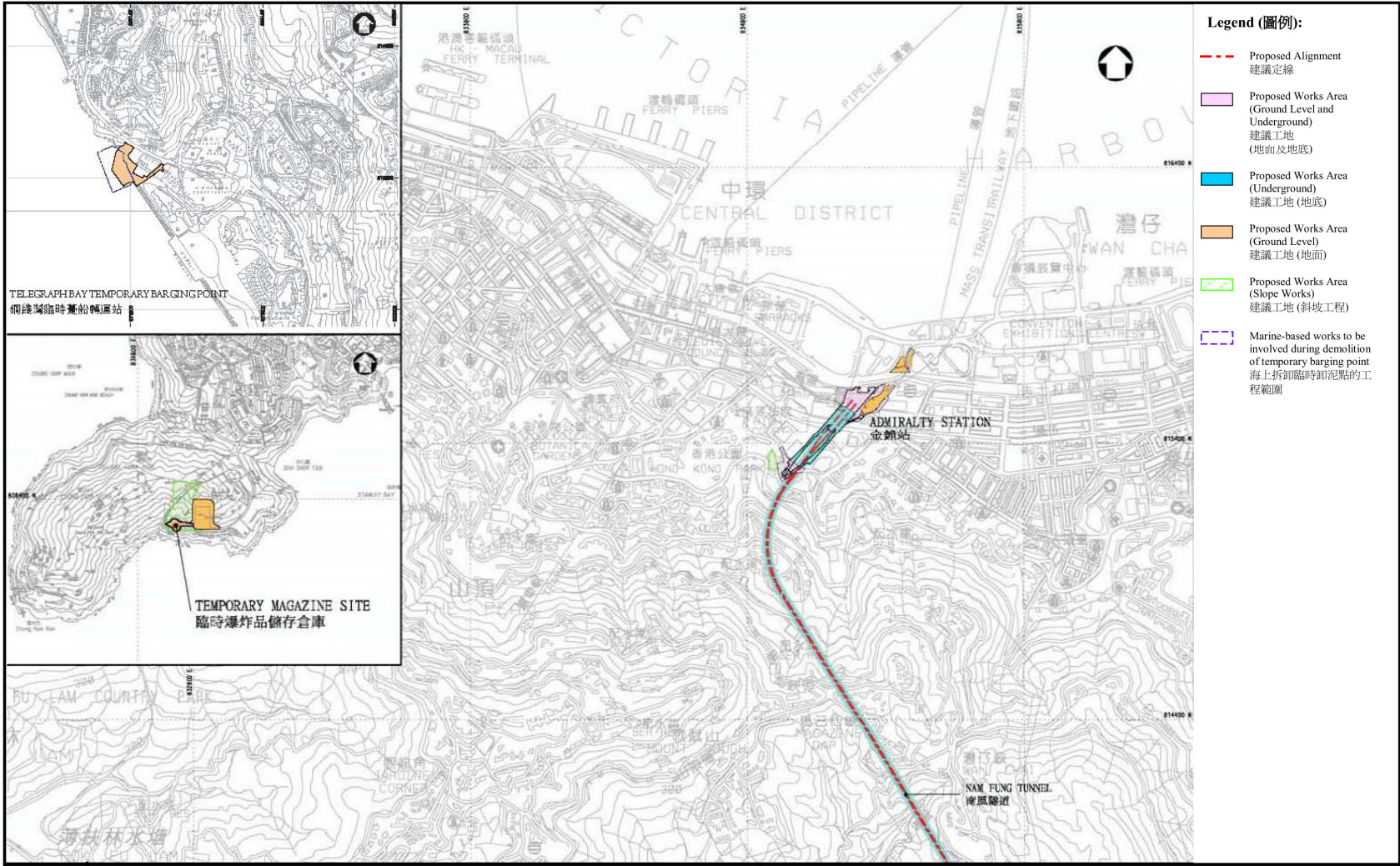

Figure 2 – Works Areas of the Project (2 of 2)

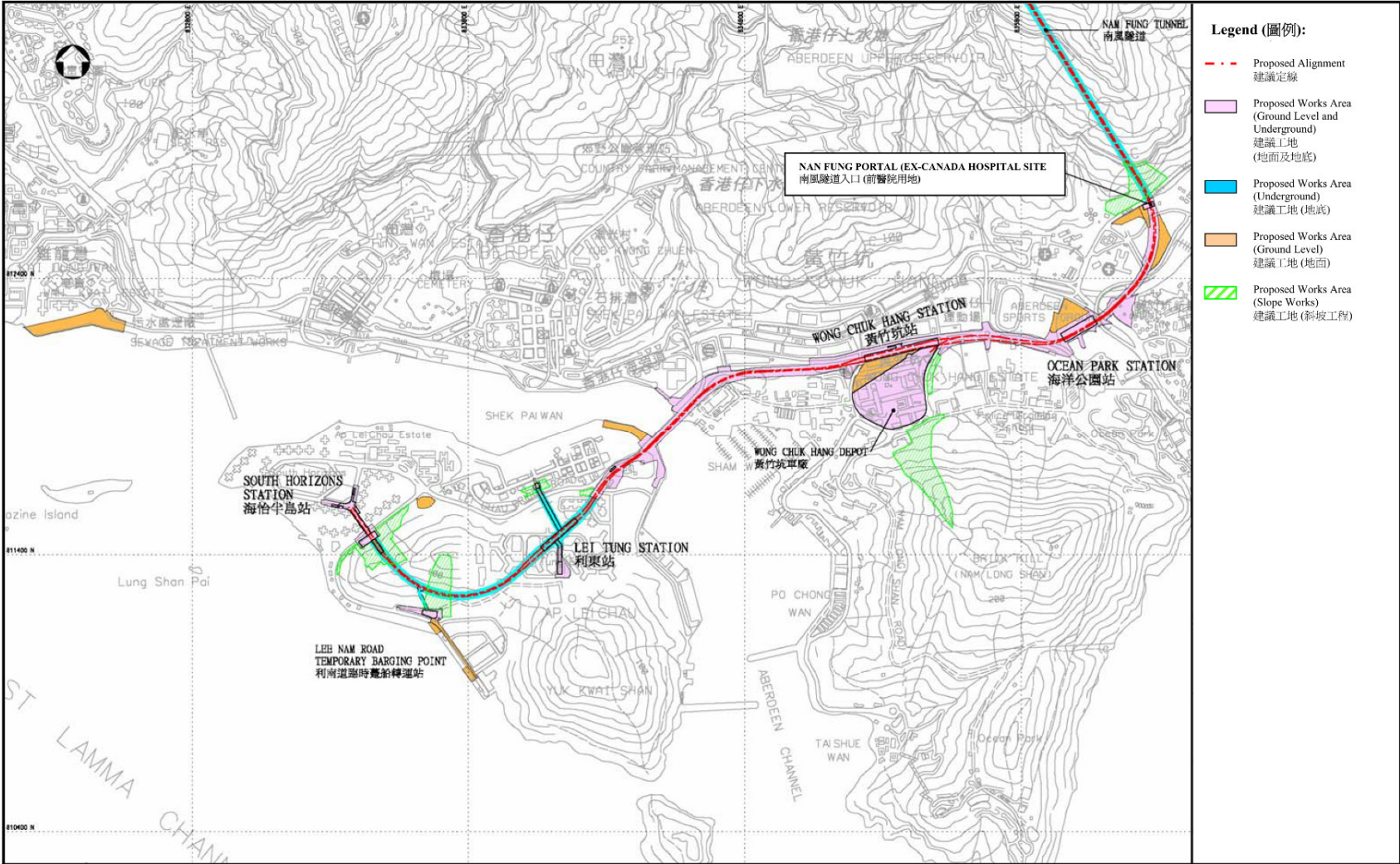

Figure 3 – Location of Construction Air Quality Monitoring Stations (1 of 4)

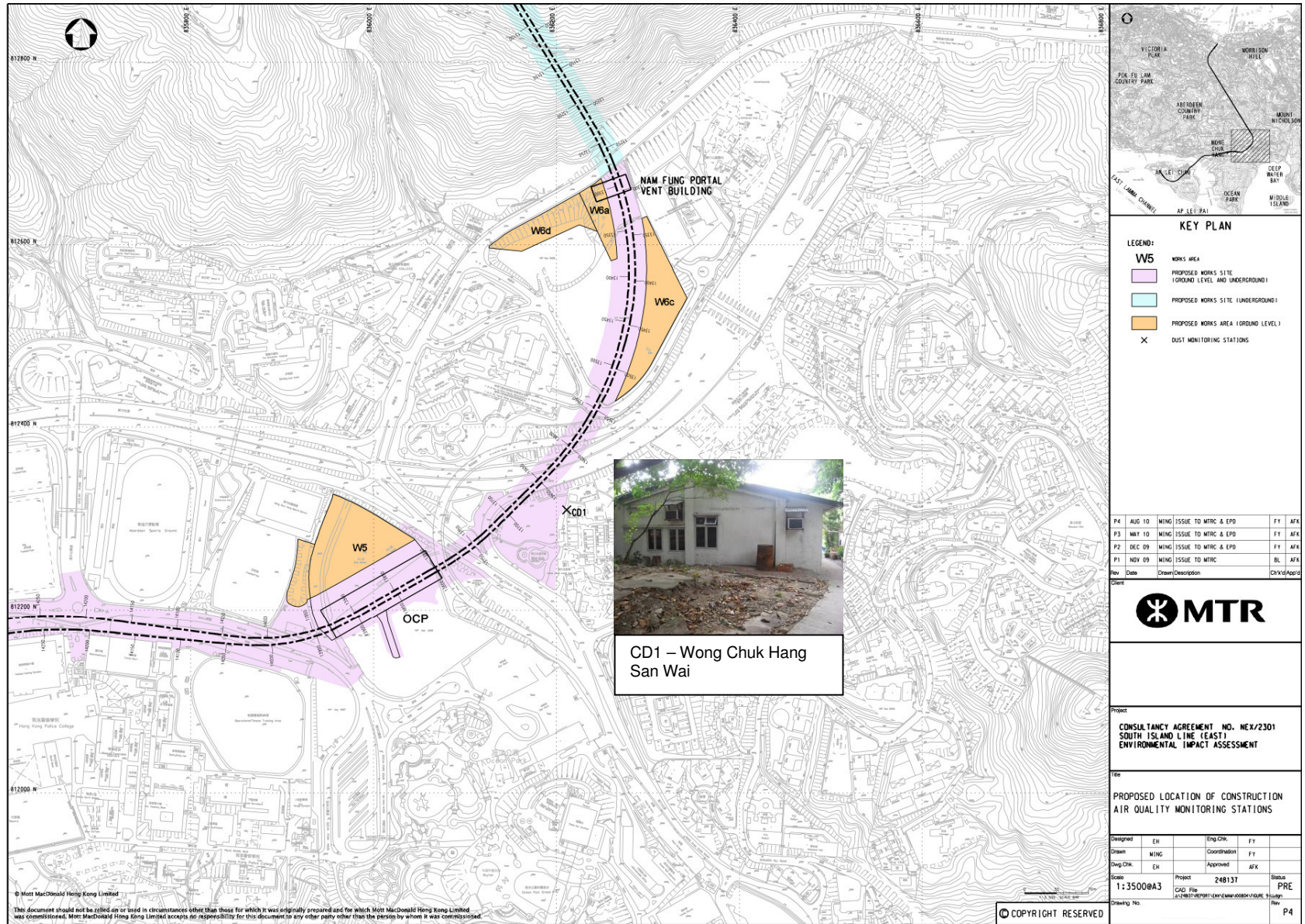

Figure 4 – Location of Construction Air Quality Monitoring Stations (2 of 4)

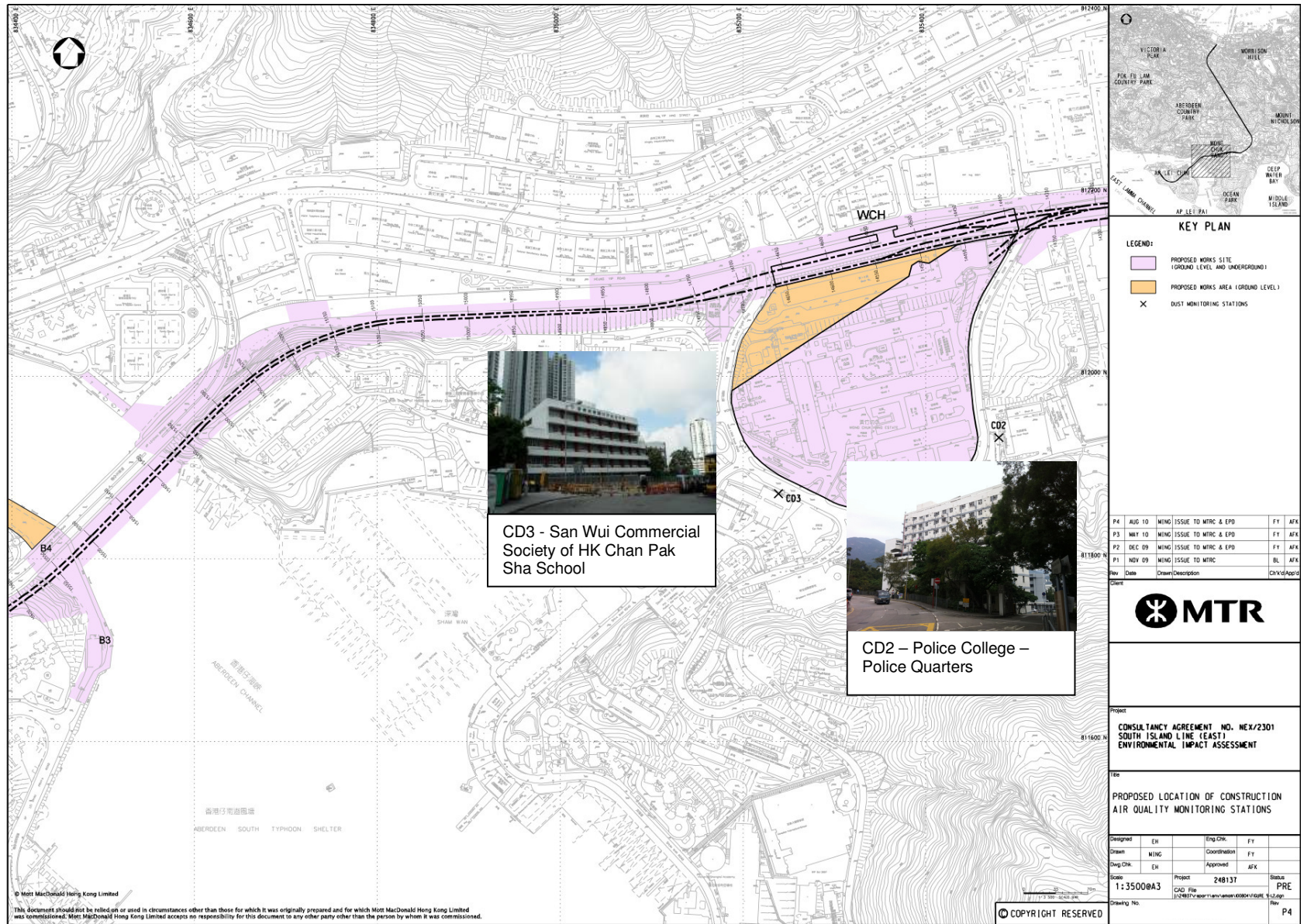

Figure 5 – Location of Construction Air Quality Monitoring Stations (3 of 4)



Figure 6 – Location of Construction Air Quality Monitoring Stations (4 of 4)



Figure 7 – Location of Construction Noise Monitoring Stations (1 of 2)

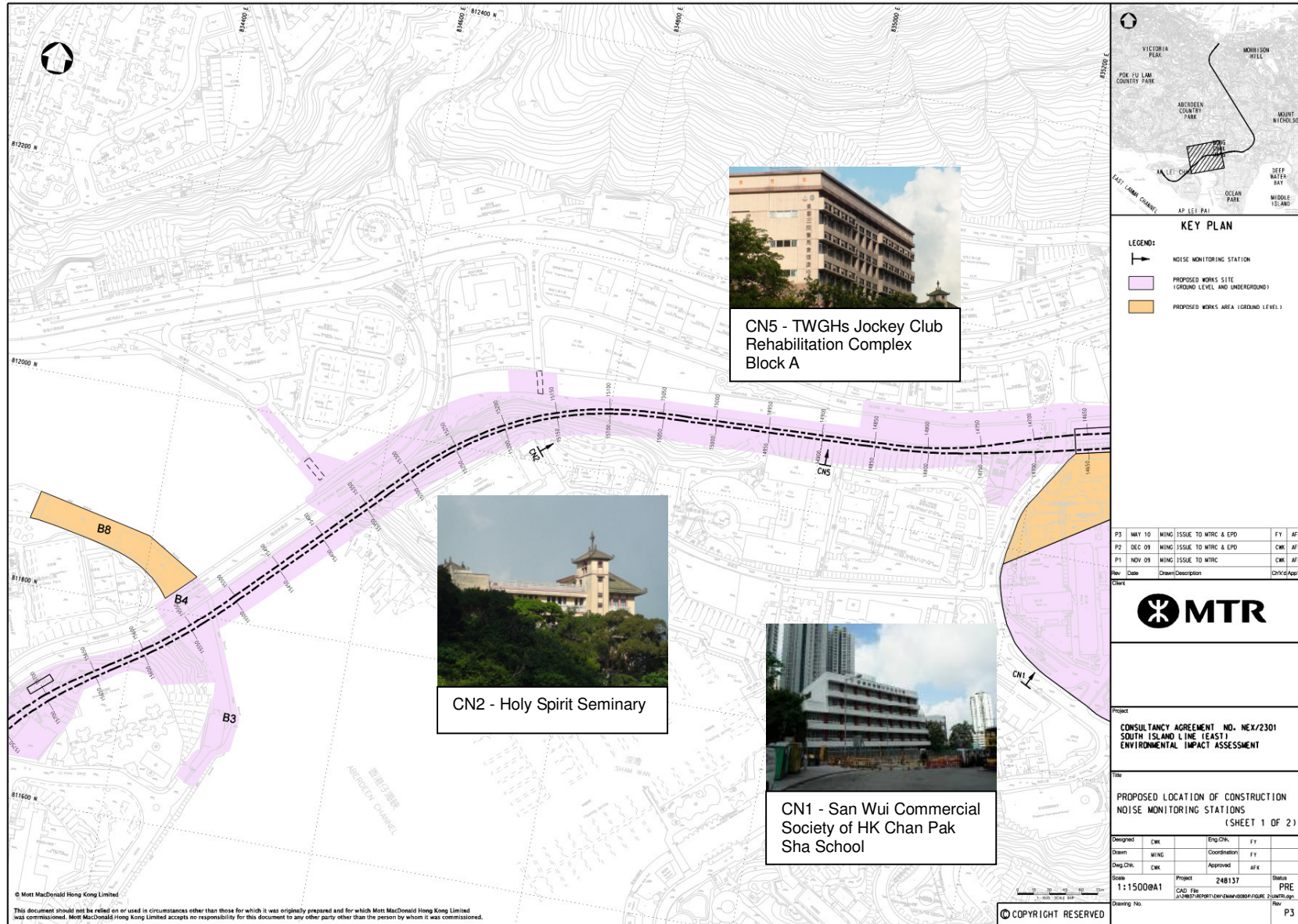

Figure 8 – Location of Construction Noise Monitoring Stations (2 of 2)

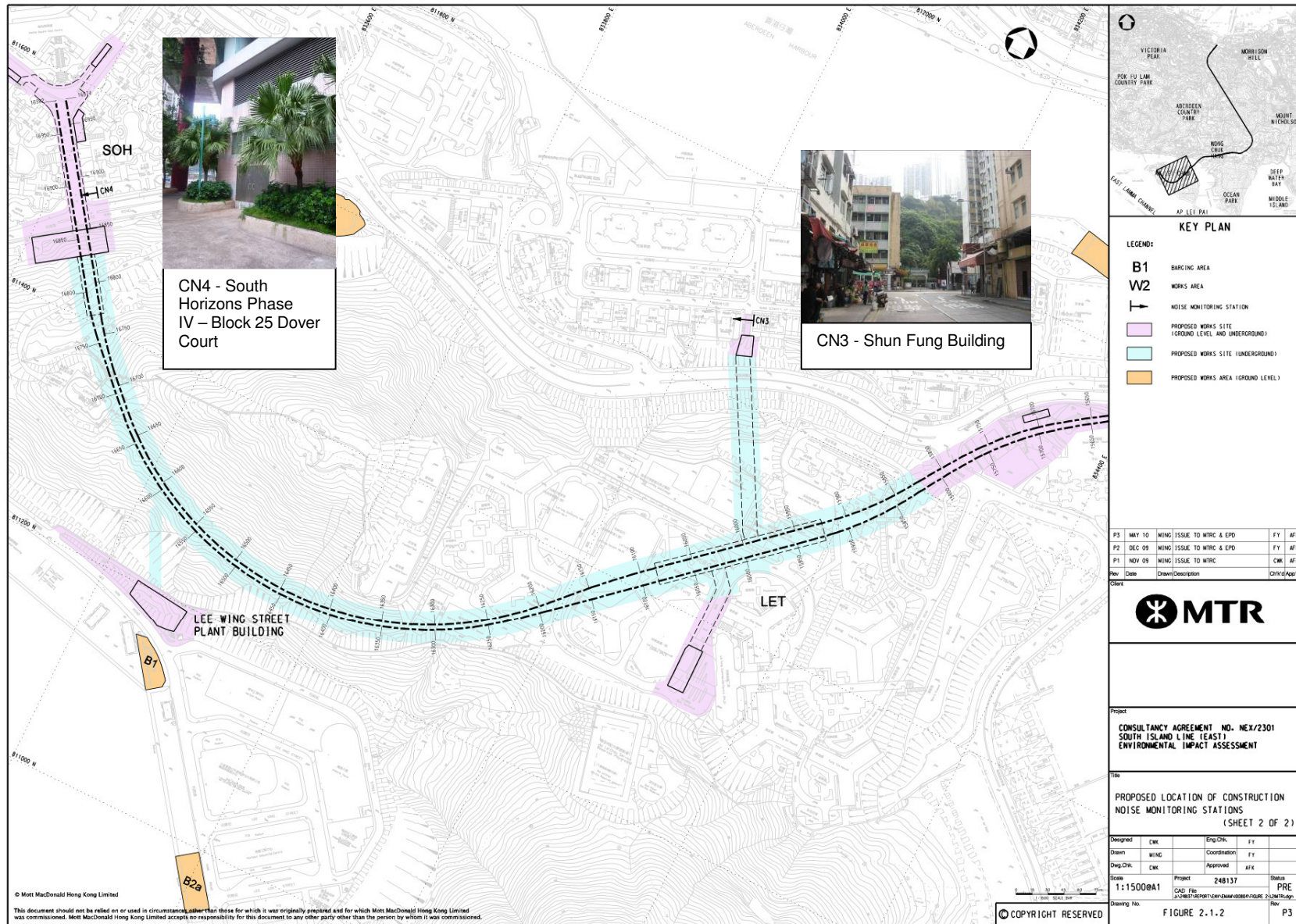
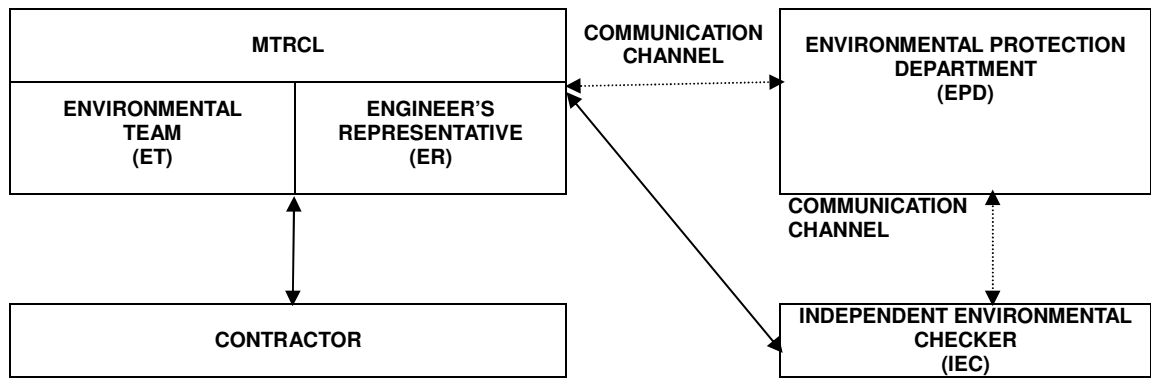

Figure 9 – Location of Water Quality Monitoring Stations



APPENDIX A1  
Project Organization

Appendix A1  
Project Organization and Lines of Communications



## APPENDIX A2

### Contact List of Key Personal of the Project

Appendix A2  
Contact List of Key Personnel

**Table A2.1 Contact List of Key Personnel of Project Management**

<b>Organization</b>	<b>Name</b>	<b>Telephone</b>
<b>Independent Environmental Checker</b>	Mr. Thomas Chan	2268 3093
<b>Environmental Team Leader</b>	Mr. Richard Kwan	2688 1179
<b>Engineer's Representative</b>		
Project Manager – SIL Civil	Mr. Mark Cuzner	3987 8288
Construction Manager – SIL (901)	Mr. Alan Boden	2206 8688
Construction Manager – SIL (902 / 904)	Mr. Ken Wong	2285 4688
Construction Manager – SIL (903 / 907 / 908)	Mr. Kit Chan	3975 6988
<b>Contract No. 901</b>		
<b>Admiralty Integrated Station and SCL Enabling Works</b>		
Main Contractor: Kier – Laing O'Rourke – Kaden Joint Venture		
Project Director	Mr. Matthew Bowe	9726 6117
QA & Environmental Manager	Mr. Ronald Fung	9777 7667
<b>Contract No. 902</b>		
<b>Nam Fung Tunnel and Ventilation Buildings</b>		
Main Contractor: Nishimatsu Construction Co., Ltd.		
Contractors Representative	Mr. Colin Birky	9641 2485
Project Manager	Mr. Kozo Suguta	9227 9717
<b>Contract No. 903</b>		
<b>Ocean Park Station, Wong Chuk Hang Station, Viaduct and Aberdeen Channel Bridge</b>		
Main Contractor: Leighton Contractors (Asia) Ltd.		
Project Director	Mr. Paul Freeman	9856 1988
Project Manager, Stations and Nullah	Mr. Ian Rawsthorne	9383 0735
Project Manager, Viaducts, Bridge and Precast	Mr. Jon Kitching	9101 9013

<b>Organization</b>	<b>Name</b>	<b>Telephone</b>
<b>Contract No. 904</b>		
<b>Lei Tung Station, South Horizons Station and Tunnels</b>		
Main Contractor: Leighton – John Holland Joint Venture		
Operation Manager	Mr. Brain Gillon	2823 1178
Project Manager	Mr. Ken Henderson	2823 1134
<b>Contract No. 907</b>		
<b>Wong Chuk Hang Depot Site Formation and Piling</b>		
Main Contractor: Chun Wo – Hip Hing Joint Venture		
Construction Manager	Mr. Wallace Yeung	9773 9711
Project Manager	Mr. Patrick Wong	9465 1064

**Table A2.2 Contact List of Key Personnel of EPD**

<b>Organization</b>	<b>Name</b>	<b>Telephone</b>
<b>EPD</b>		
Sr Env Protection Offr (Metro Assessment)	Mr. Steve Li	2835 1142
Sr Env Protection Offr (Regional S)	Mr. YK Chan	2516 1802
Sr Env Protection Offr (Regional S)	Mr. Sean Law	2516 1806

## APPENDIX B1

### Action and Limit Levels for Construction Noise and Air Quality

Appendix B1

Action and Limit Levels for Construction Noise and Air Quality

**Action and Limit Levels for 24-hours TSP**

***Table B1.1 Action and Limit Levels for 24-hour TSP***

<b>ID</b>	<b>Description</b>	<b>Action Level (<math>\mu\text{g}/\text{m}^3</math>)</b>	<b>Limit Level (<math>\mu\text{g}/\text{m}^3</math>)</b>
CD1	Wong Chuk Hang San Wai	173	260
CD2	Police College – Police Quarters	184	260
CD3	San Wui Commercial Society of HK Chan Pak Sha School	169	260
CD4	Shan On House	176	260
CD5	South Horizons Phase IV – Block 25	169	260

Note: TSP levels are to the nearest whole number, with values of 0.5 rounded up

**Action and Limit Levels for 1-hour TSP**

***Table B1.2 Action and Limit Levels for 1-hour TSP***

<b>ID</b>	<b>Description</b>	<b>Action Level (<math>\mu\text{g}/\text{m}^3</math>)</b>	<b>Limit Level (<math>\mu\text{g}/\text{m}^3</math>)</b>
CD1	Wong Chuk Hang San Wai	315	500
CD2	Police College – Police Quarters	311	500
CD3	San Wui Commercial Society of HK Chan Pak Sha School	322	500
CD4	Shan On House	318	500
CD5	South Horizons Phase IV – Block 25	336	500

Note: 1-hour TSP criterion recommended in the EIAO-TM  
TSP levels are to the nearest whole number, with values of 0.5 rounded up

## Action and Limit Levels for Construction Noise

**Table B1.3 Action and Limit Levels for Construction Noise**

Time Period	Action Level	Limit Level
Daytime (0700-1900), Monday through Saturday excluding Public Holidays	When one document complaint received.	$L_{Aeq\ 30mins} 75dB(A)^{(1)(2)}$
All evenings (1900-2300)		Subject to control under the Noise Control Ordinance
General Holidays (including all Sundays) during the daytime and evening (0700-2300)		Subject to control under the Noise Control Ordinance
All night time periods (2300-0700)		Subject to control under the Noise Control Ordinance

(1) 70dB(A) for schools and 65dB(A) during school examination periods.

(2) Updated prediction of noise levels as contained in the construction noise mitigation measures plan.

## APPENDIX B2

### Action and Limit Levels for Water Quality

Appendix B2  
Action and Limit Levels for Water Quality

**Table B2.1 Action and Limit Levels for Ebb Condition**

Tide: <b>Ebb</b>				
Location: <b>WM1</b>				
Parameters	Action Level		Limit Level	
DO in mg/L	Surface	5.9	Surface	5.5
	Middle	6.0	Middle	5.6
	Bottom	6.0	Bottom	5.7
SS in mg/L (depth averaged)	120% of upstream control station of the same day		130% of upstream control station of the same day	
Turbidity in NTU (depth averaged)	120% of upstream control station of the same day		130% of upstream control station of the same day	
Tide: <b>Ebb</b>				
Location: <b>WM2</b>				
Parameters	Action Level		Limit Level	
DO in mg/L	Surface	5.9	Surface	5.5
	Middle	NA	Middle	NA
	Bottom	6.0	Bottom	5.7
SS in mg/L (depth averaged)	120% of upstream control station of the same day		130% of upstream control station of the same day	
Turbidity in NTU (depth averaged)	120% of upstream control station of the same day		130% of upstream control station of the same day	
Tide: <b>Ebb</b>				
Location: <b>WM3</b>				
Parameters	Action Level		Limit Level	
DO in mg/L	Surface	6.1	Surface	5.7
	Middle	6.1	Middle	5.7
	Bottom	6.3	Bottom	5.9
SS in mg/L (depth averaged)	120% of upstream control station of the same day		130% of upstream control station of the same day	
Turbidity in NTU (depth averaged)	120% of upstream control station of the same day		130% of upstream control station of the same day	
Tide: <b>Ebb</b>				
Location: <b>WM4</b>				
Parameters	Action Level		Limit Level	
DO in mg/L	Surface	6.1	Surface	5.8
	Middle	6.3	Middle	6.0
	Bottom	6.5	Bottom	6.2
SS in mg/L (depth averaged)	120% of upstream control station of the same day		130% of upstream control station of the same day	
Turbidity in NTU (depth averaged)	120% of upstream control station of the same day		130% of upstream control station of the same day	

**Table B2.2 Action and Limit Levels for Flood Condition**

Tide: <b>Flood</b>				
Location: <b>WM1</b>				
Parameters	Action Level		Limit Level	
DO in mg/L	Surface	5.9	Surface	5.6
	Middle	6.1	Middle	5.7
	Bottom	6.2	Bottom	5.8
SS in mg/L (depth averaged)	120% of upstream control station of the same day		130% of upstream control station of the same day	
Turbidity in NTU (depth averaged)	120% of upstream control station of the same day		130% of upstream control station of the same day	
Tide: <b>Flood</b>				
Location: <b>WM2</b>				
Parameters	Action Level		Limit Level	
DO in mg/L	Surface	6.0	Surface	5.7
	Middle	NA	Middle	NA
	Bottom	6.1	Bottom	5.8
SS in mg/L (depth averaged)	120% of upstream control station of the same day		130% of upstream control station of the same day	
Turbidity in NTU (depth averaged)	120% of upstream control station of the same day		130% of upstream control station of the same day	
Tide: <b>Flood</b>				
Location: <b>WM3</b>				
Parameters	Action Level		Limit Level	
DO in mg/L	Surface	6.0	Surface	5.7
	Middle	6.2	Middle	5.8
	Bottom	6.2	Bottom	5.9
SS in mg/L (depth averaged)	120% of upstream control station of the same day		130% of upstream control station of the same day	
Turbidity in NTU (depth averaged)	120% of upstream control station of the same day		130% of upstream control station of the same day	
Tide: <b>Flood</b>				
Location: <b>WM4</b>				
Parameters	Action Level		Limit Level	
DO in mg/L	Surface	6.0	Surface	5.8
	Middle	6.2	Middle	5.8
	Bottom	6.3	Bottom	6.1
SS in mg/L (depth averaged)	120% of upstream control station of the same day		130% of upstream control station of the same day	
Turbidity in NTU (depth averaged)	120% of upstream control station of the same day		130% of upstream control station of the same day	

## APPENDIX C

### Calibration Details

## Summary of Calibration Certificate

### Noise Equipment

Model	Serial Number	Calibration Date	Expiry Date	Remark
B&K 2250L	2741137	21 Jan 2011	21 Jan 2013 <sup>[1]</sup>	
B&K 2250	2551244	25 Jan 2011	25 Jan 2013 <sup>[1]</sup>	
B&K 4231 Calibrator	2725557	15 Jun 2011	15 Jun 2013 <sup>[1]</sup>	
B&K 4231 Calibrator	2309393	15 Jun 2011	15 Jun 2013 <sup>[1]</sup>	

### High Volume Sampler

Model	Sampler	Calibration Date	Expiry Date	Remark
Graseby-Andersen	694-0661	17 Jan 2012	17 Jul 2012 <sup>[3]</sup>	
Graseby-Andersen	894-0833	17 Jan 2012	17 Jul 2012 <sup>[3]</sup>	
Graseby-Andersen	994-0878	17 Jan 2012	17 Jul 2012 <sup>[3]</sup>	
Graseby-Andersen	1294-1104	17 Jan 2012	17 Jul 2012 <sup>[3]</sup>	
Graseby-Andersen	1294-1111	17 Jan 2012	17 Jul 2012 <sup>[3]</sup>	

### Water Quality Monitoring Equipment

Model	Serial Number	Calibration Date	Expiry Date	Remark
Turbidimeter				
HACH 2100P	06070C018334	28 Jan 2012	27 Apr 2012 <sup>[2]</sup>	
HACH 2100P	08060C030281	13 Jan 2012	12 Apr 2012 <sup>[2]</sup>	
pH Meter				
HANNA HI8314	674469	11 Feb 2012	10 Mar 2012 <sup>[3]</sup>	
HANNA HI8314	674469	10 Mar 2012	9 Apr 2012	
Multimeter for Temperature / Dissolved Oxygen / Salinity				
YSI 85	05L1285	28 Jan 2012	27 Apr 2012 <sup>[2]</sup>	
YSI Pro2030	10F 101978	13 Feb 2012	12 May 2012	

- Note: [1] Calibration certificates refer to Appendix C of EM&A report - August 2011  
 [2] Calibration certificates refer to Appendix C of EM&A report - February 2012  
 [3] Calibration certificates refer to Appendix C of EM&A report - March 2012



### Internal Calibration & Performance Check Report of pH Meter

Equipment Ref. No. : ET/EW/007/003      Manufacturer : HANNA  
 Model No. : HI 8314      Serial No. : 674469  
 Date of Calibration : 10/03/2012      Calibration Due Date : 09/04/2012

#### Liquid Junction Error

Primary Standard Solution Used : Phosphate      Ref No. of Primary Solution: 003/5.2/001/8  
 Temperature of Solution : 20.0      pH<sub>½</sub> = +0.08  
 pH value of diluted buffer : 6.78      pH (S) = 6.881  
 pH = pH(S) - pH of diluted buffer = 0.101 (Observed Deviation)  
 Liquid Junction Error ( pH<sub>j</sub>) = pH - pH<sub>½</sub> = 0.021

#### Shift on Stirring

pH of buffer solution (with stirring), pH<sub>s</sub> = 6.92  
 Shift on stirring, pH<sub>s</sub> = pH<sub>s</sub> - pH(S) - pH<sub>j</sub> = 0.018

#### Noise

Noise, pH<sub>n</sub> = difference between max and min reading : 0.01

#### Verification of ATC

Ref. No. of reference thermometer used: ET/0521/001  
 Temperature record from the reference thermometer (T<sub>R</sub>): 20.0 °C  
 Temperature record from the ATC (T<sub>ATC</sub>): 19.9 °C  
 Temperature Difference (T<sub>R</sub> - T<sub>ATC</sub>): 0.1 °C

#### Acceptance Criteria

Performance Characteristic	Acceptable Range
Liquid Junction Error      pH <sub>j</sub>	≤0.05
Shift on Stirring      pH <sub>s</sub>	≤0.02
Noise      pH <sub>n</sub>	≤0.02
Verification of ATC      Temperature Difference	≤0.5°C

The pH meter complies \* / does not comply \* with the specified requirements and is deemed acceptable \* / unacceptable \* for use. Measurements are traceable to national standards.

\* Delete as appropriate

Calibrated by : Idelam

Approved Signatory : [Signature]



### Internal Calibration Report of Dissolved Oxygen Meter

Equipment Ref. No. : <u>ET/EW/008/004</u>	Manufacturer : <u>YSI</u>
Model No. : <u>Pro 2030</u>	Serial No. : <u>10F 101978</u>
Date of Calibration : <u>13/02/2012</u>	Calibration Due Date : <u>12/05/2012</u>

#### *Temperature Verification*

Ref. No. of Reference Thermometer : ET/0521/001  
Ref. No. of Water Bath : ---

Reference Thermometer reading	Temperature (°C)		
	Measured	20.2	Corrected
DO Meter reading	Measured	19.8	Difference
			0.1

#### *Standardization of sodium thiosulphate (Na<sub>2</sub>S<sub>2</sub>O<sub>3</sub>) solution*

Reagent No. of Na <sub>2</sub> S <sub>2</sub> O <sub>3</sub> titrant	CPE/012/4.5/001/4	Reagent No. of 0.025N K <sub>2</sub> Cr <sub>2</sub> O <sub>7</sub>	CPE/012/4.4/001/7
		Trial 1	Trial 2
Initial Vol. of Na <sub>2</sub> S <sub>2</sub> O <sub>3</sub> (ml)		0.00	0.00
Final Vol. of Na <sub>2</sub> S <sub>2</sub> O <sub>3</sub> (ml)		40.00	39.50
Vol. of Na <sub>2</sub> S <sub>2</sub> O <sub>3</sub> used (ml)		40.00	39.50
Normality of Na <sub>2</sub> S <sub>2</sub> O <sub>3</sub> solution (N)		0.02500	0.02532
Average Normality (N) of Na <sub>2</sub> S <sub>2</sub> O <sub>3</sub> solution (N)		0.02516	
Acceptance criteria, Deviation		Less than ± 0.001N	

Calculation: Normality of Na<sub>2</sub>S<sub>2</sub>O<sub>3</sub>, N = 1 / ml Na<sub>2</sub>S<sub>2</sub>O<sub>3</sub> used

#### *Lineality Checking*

##### *Determination of dissolved oxygen content by Winkler Titration \**

Purging Time (min)	2		5		10	
	1	2	1	2	1	2
Trial						
Initial Vol. of Na <sub>2</sub> S <sub>2</sub> O <sub>3</sub> (ml)	0.00	11.10	22.10	0.00	7.40	12.20
Final Vol. of Na <sub>2</sub> S <sub>2</sub> O <sub>3</sub> (ml)	11.10	22.10	29.60	7.40	12.20	17.10
Vol. (V) of Na <sub>2</sub> S <sub>2</sub> O <sub>3</sub> used (ml)	11.10	11.00	7.50	7.40	4.80	4.90
Dissolved Oxygen (DO), mg/L	7.50	7.43	5.07	5.00	3.24	3.31
Acceptance criteria, Deviation	Less than + 0.3mg/L		Less than + 0.3mg/L		Less than + 0.3mg/L	

Calculation: DO (mg/L) = V x N x 8000/298

Purging time, min	DO meter reading, mg/L			Winkler Titration result *, mg/L			Difference (%) of DO Content
	1	2	Average	1	2	Average	
2	7.56	7.54	7.55	7.50	7.43	7.47	1.07
5	5.22	5.20	5.21	5.07	5.00	5.04	3.32
10	3.22	3.24	3.23	3.24	3.31	3.28	1.54
Linear regression coefficient				0.99807			



## Internal Calibration Report of Dissolved Oxygen Meter

### Zero Point Checking

DO meter reading, mg/L	0.00
------------------------	------

### Salinity Checking

Reagent No. of NaCl (10ppt)	CPE/012/4.7/001/17	Reagent No. of NaCl (30ppt)	CPE/012/4.8/001/17
-----------------------------	--------------------	-----------------------------	--------------------

### Determination of dissolved oxygen content by Winkler Titration \*\*

Salinity (ppt)	10		30	
	1	2	1	2
Trial				
Initial Vol. of Na <sub>2</sub> S <sub>2</sub> O <sub>3</sub> (ml)	0.00	11.50	23.10	33.60
Final Vol. of Na <sub>2</sub> S <sub>2</sub> O <sub>3</sub> (ml)	11.50	23.10	33.60	44.00
Vol. (V) of Na <sub>2</sub> S <sub>2</sub> O <sub>3</sub> used (ml)	11.50	11.60	10.50	10.40
Dissolved Oxygen (DO), mg/L	7.77	7.84	7.09	7.02
Acceptance criteria, Deviation	Less than + 0.3mg/L		Less than + 0.3mg/L	

Calculation: DO (mg/L) = V x N x 8000/298

Salinity (ppt)	DO meter reading, mg/L			Winkler Titration result**, mg/L			Difference (%) of DO Content
	1	2	Average	1	2	Average	
10	7.72	7.76	7.74	7.77	7.84	7.81	0.90
30	7.10	7.08	7.09	7.09	7.02	7.06	0.42

### Acceptance Criteria

- (1) Differenc between temperature readings from temperature sensor of DO probe and reference thermometer : < 0.5 °C
- (2) Linear regression coefficient : >0.99
- (3) Zero checking: 0.0mg/L
- (4) Difference (%) of DO content from the meter reading and by winkler titration : within ± 5%

The equipment complies # / ~~does not comply~~ # with the specified requirements and is deemed acceptable # / unacceptable # for use.

# Delete as appropriate

Calibrated by

:

hde com

Approved by :

[Signature]



## Performance Check of Salinity Meter

Equipment Ref. No. : ET/EW/008/004 Manufacturer : YSI

Model No. : Pro 2030 Serial No. : 10F 101978

Date of Calibration : 13/02/2012 Due Date : 12/05/2012

Ref. No. of Salinity Standard used (30ppt)

S/001/3

Salinity Standard (ppt)	Measured Salinity (ppt)	Difference %
30	30.3	1.00

Acceptance Criteria

Difference : <10 %

The salinity meter complies \* / ~~does not comply~~ \* with the specified requirements and is deemed acceptable \* / ~~unacceptable~~ \* for use. Measurements are traceable to national standards.

Checked by : 

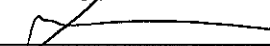
Approved by : 

## APPENDIX D

Graphical Plots of Air Quality, Noise & Water Quality Impact Monitoring  
and Monitoring Results for Water Quality

# Graphical Plots of Air Quality Monitoring Results

## 24-hr TSP Level at CD1 Wong Chuk Hang San Wai

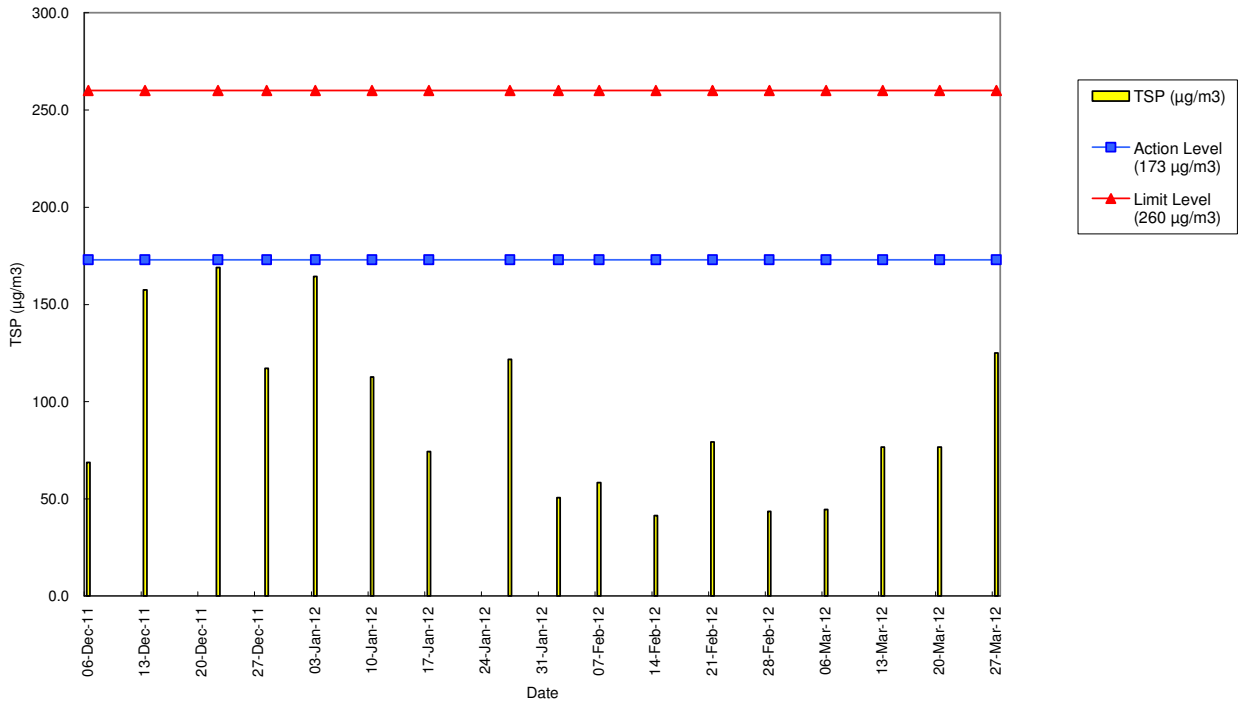

## 24-hr TSP Level at CD2 Police College - Police Quarters

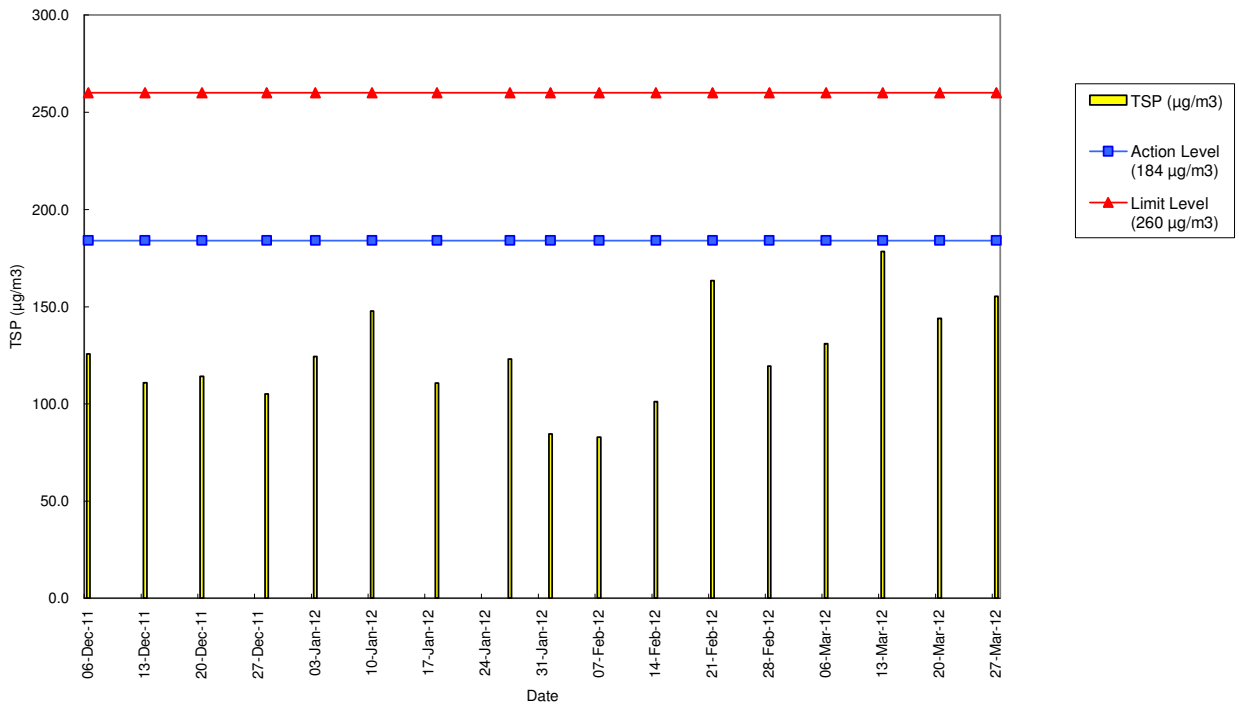

## Graphical Plots of Air Quality Monitoring Results

24-hr TSP Level at CD3 San Wui Commercial Society of HK Chan Pak Sha School

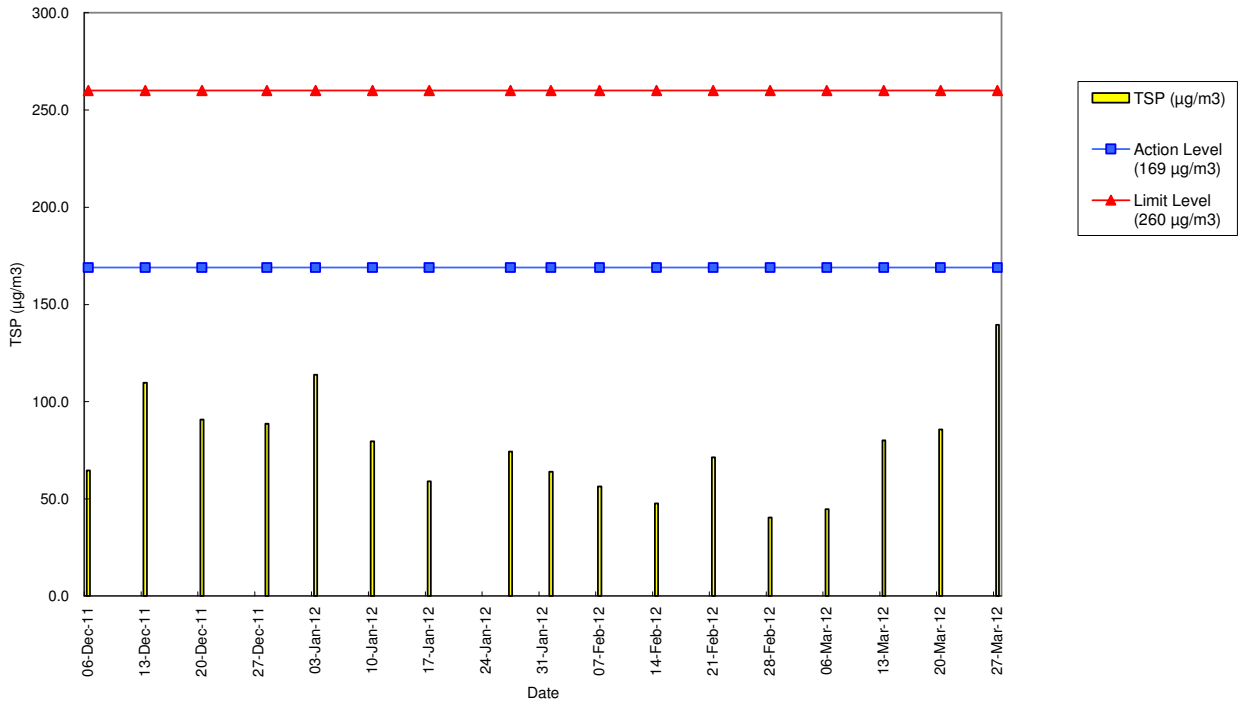

24-hr TSP Level at CD4 Shan On House

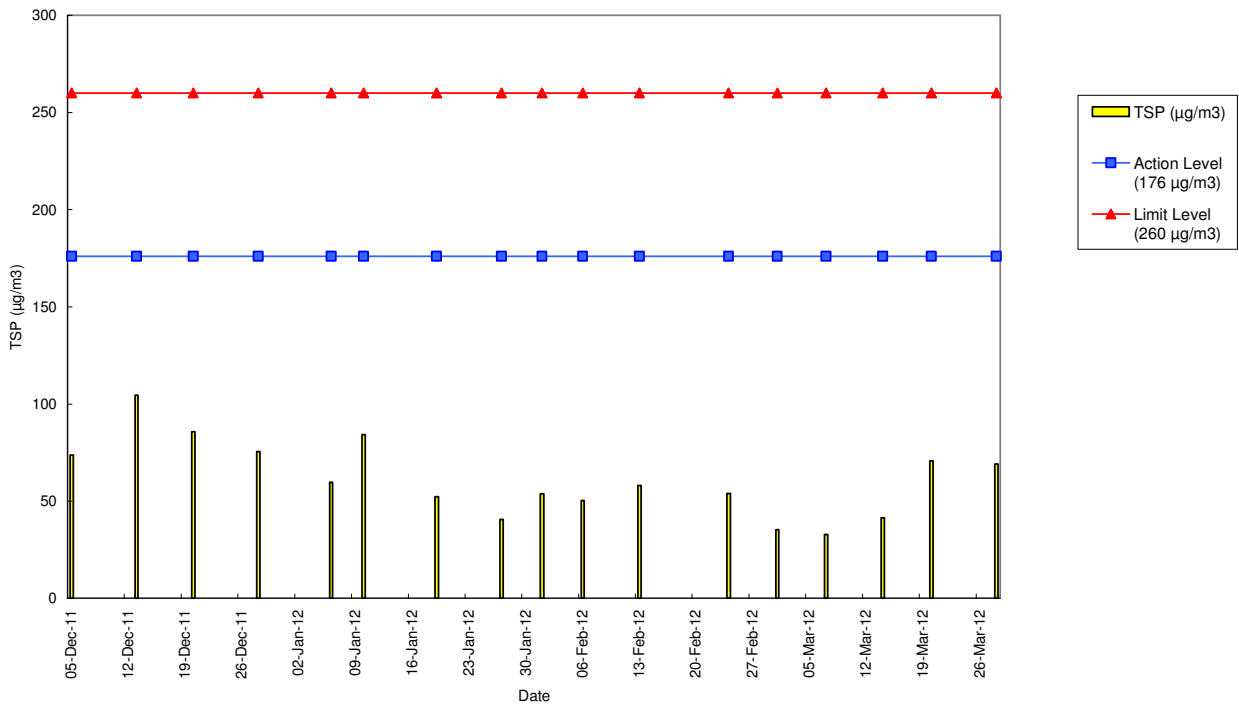

# Graphical Plots of Air Quality Monitoring Results

24-hr TSP Level at CD5 South Horizons Phase IV – Block 25

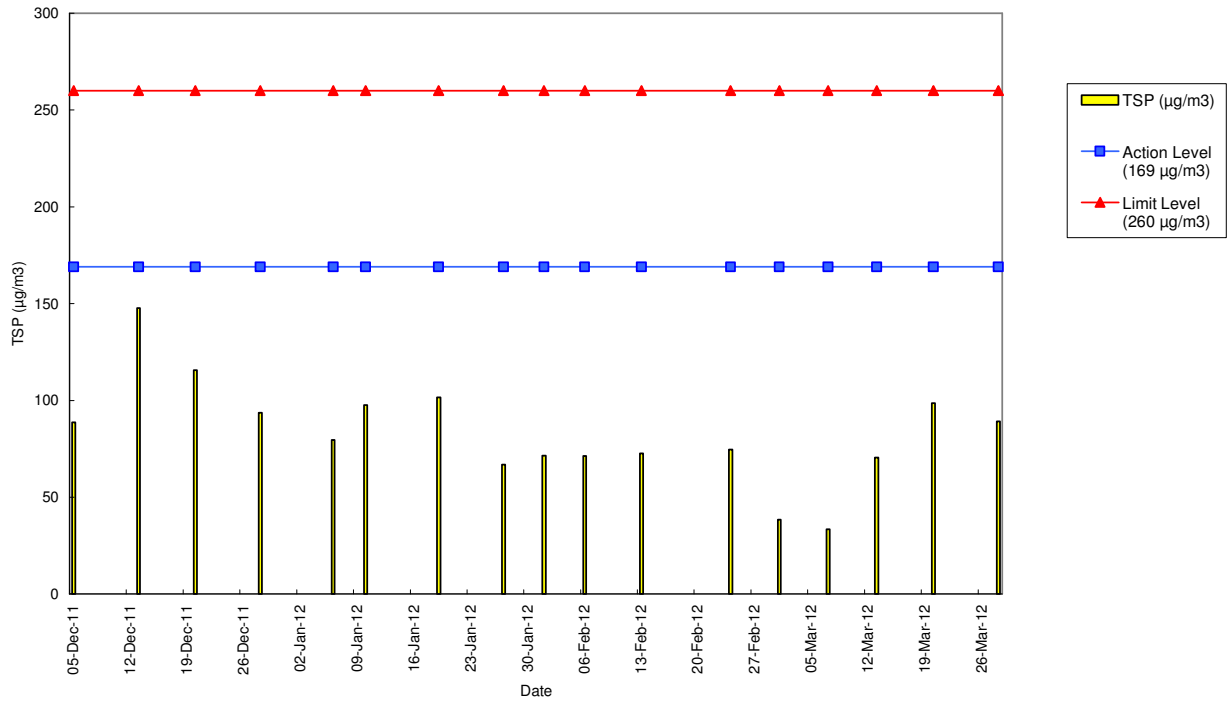

## Graphical Plots of Noise Monitoring Results

**Noise Level at CN1 San Wui Commercial Society of HK Chan Pak Sha School (Educational Institution)**

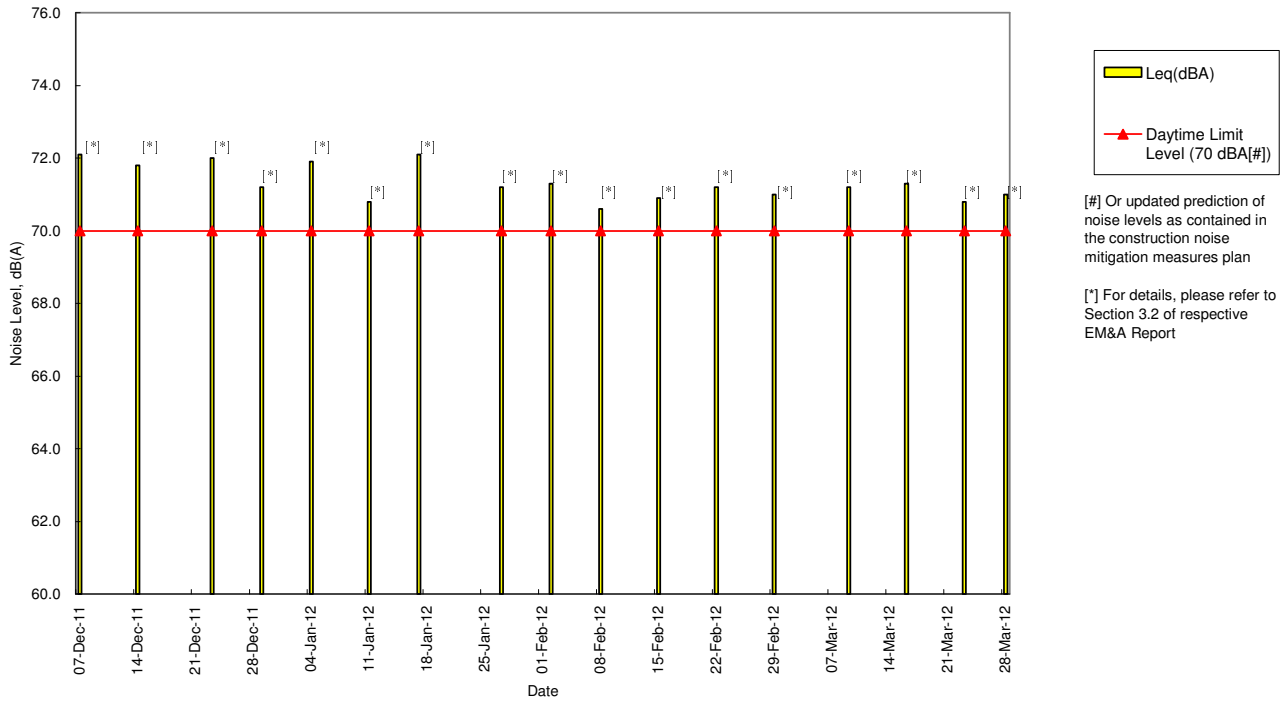

**Noise Level at CN2 Holy Spirit Seminary (Educational Institution)**

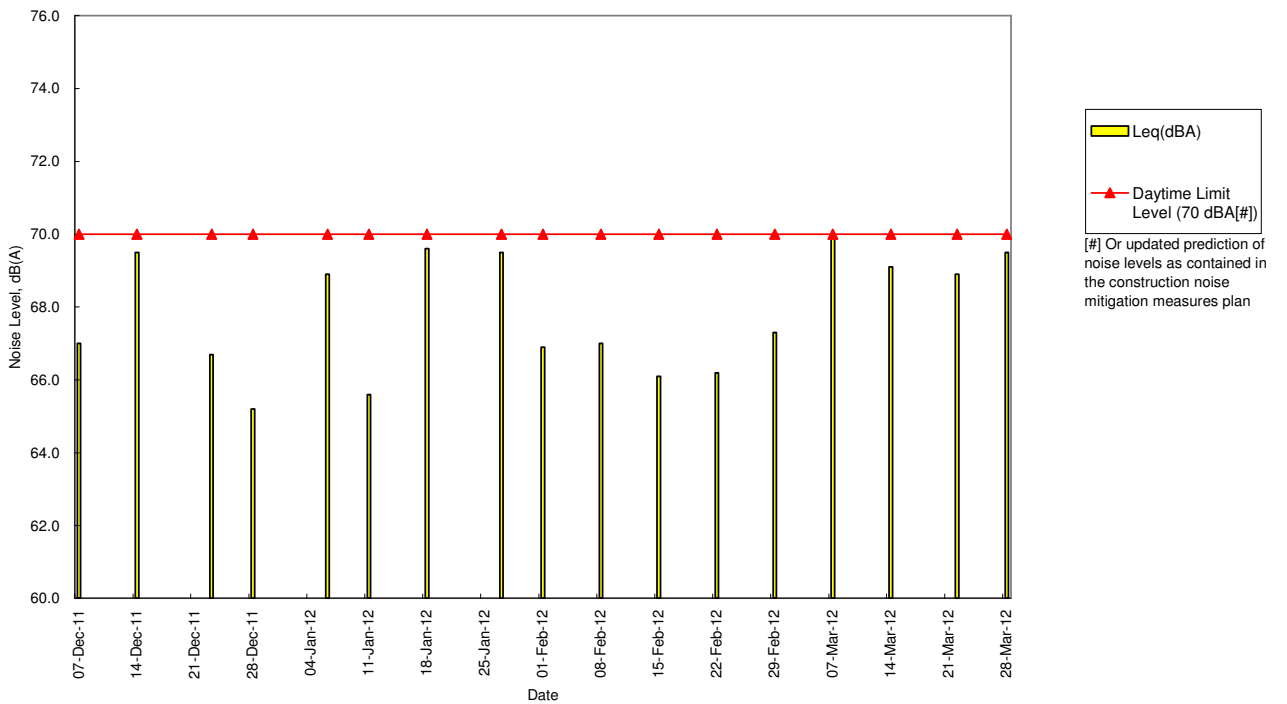

## Graphical Plots of Noise Monitoring Results

Noise Level at CN3 Shun Fung Building (Residential)

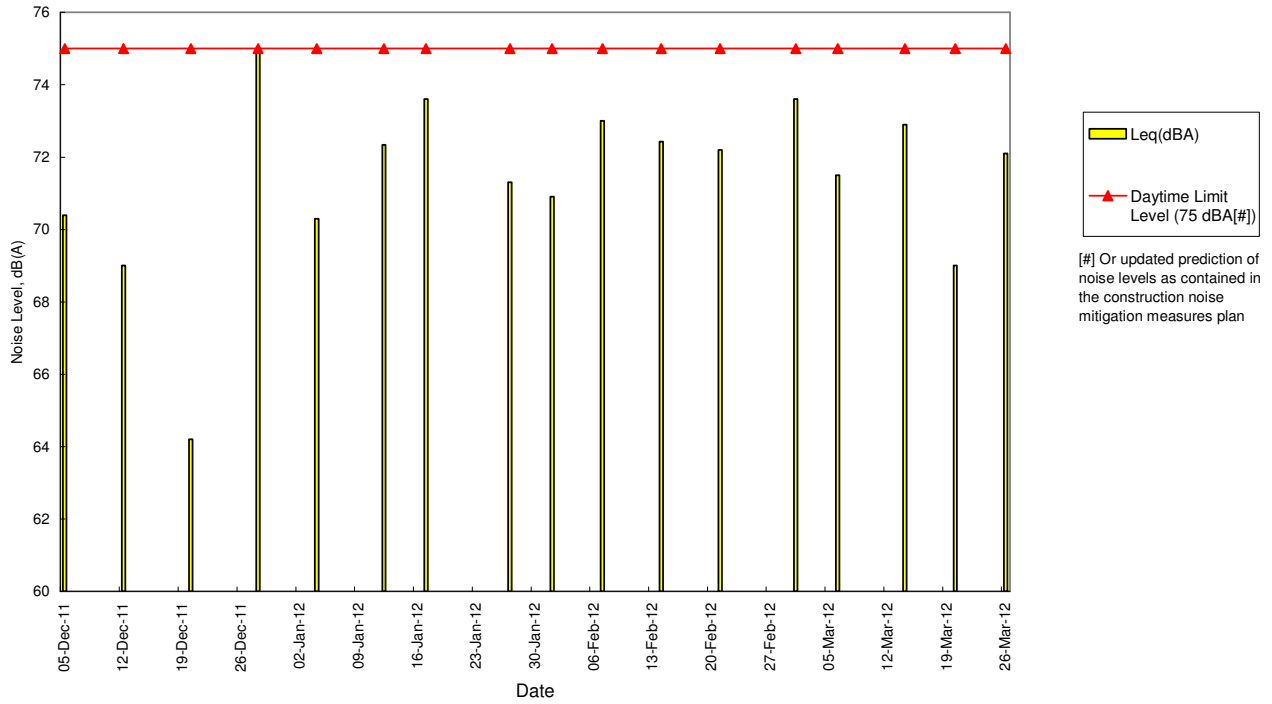

Noise Level at CN4 South Horizons Phase IV – Block 25 Dover Court (Residential)

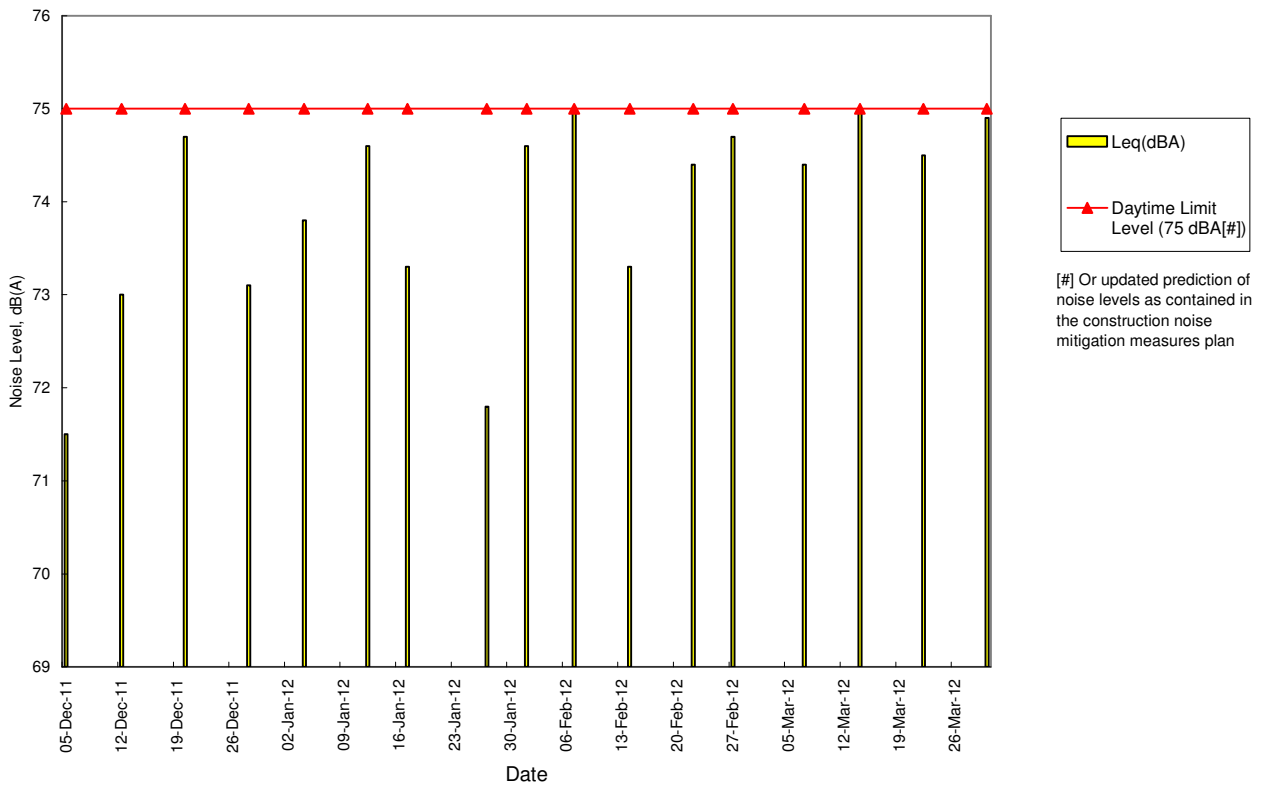

# Graphical Plots of Noise Monitoring Results

Noise Level at CN5 TWGHs Jockey Club Rehabilitation Complex Block A (Convalescent Home)

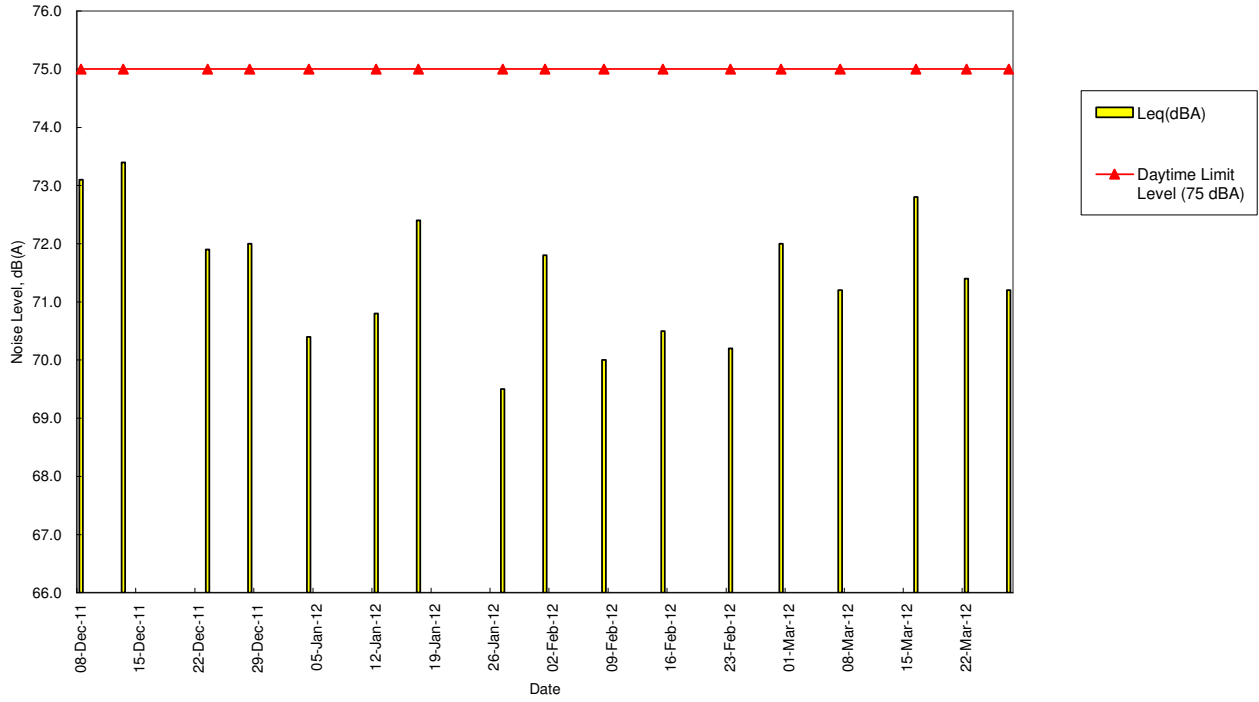

## Graphical Plots of Water Quality Monitoring Results

### Monitoring Results for Dissolved Oxygen in Flood Tide - Surface Level

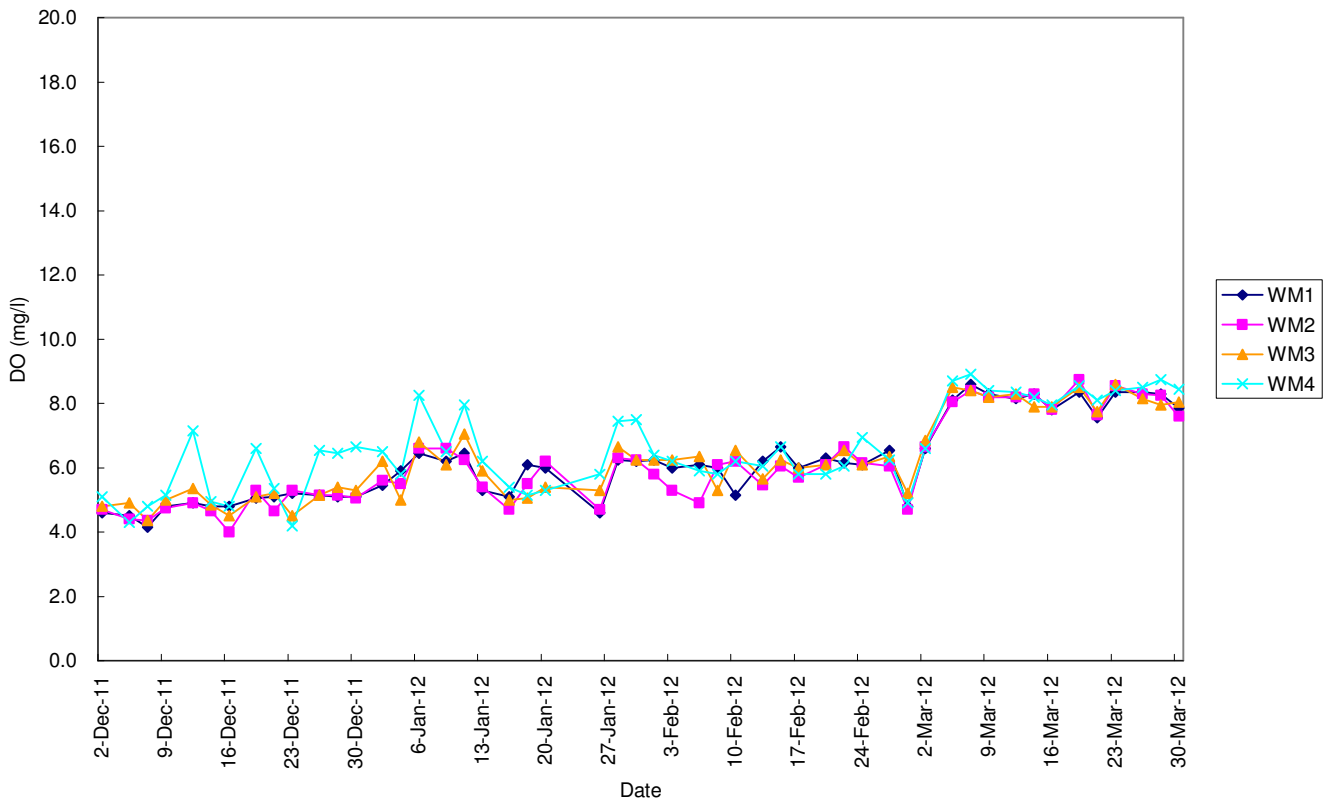

### Monitoring Results for Dissolved Oxygen in Flood Tide - Middle Level

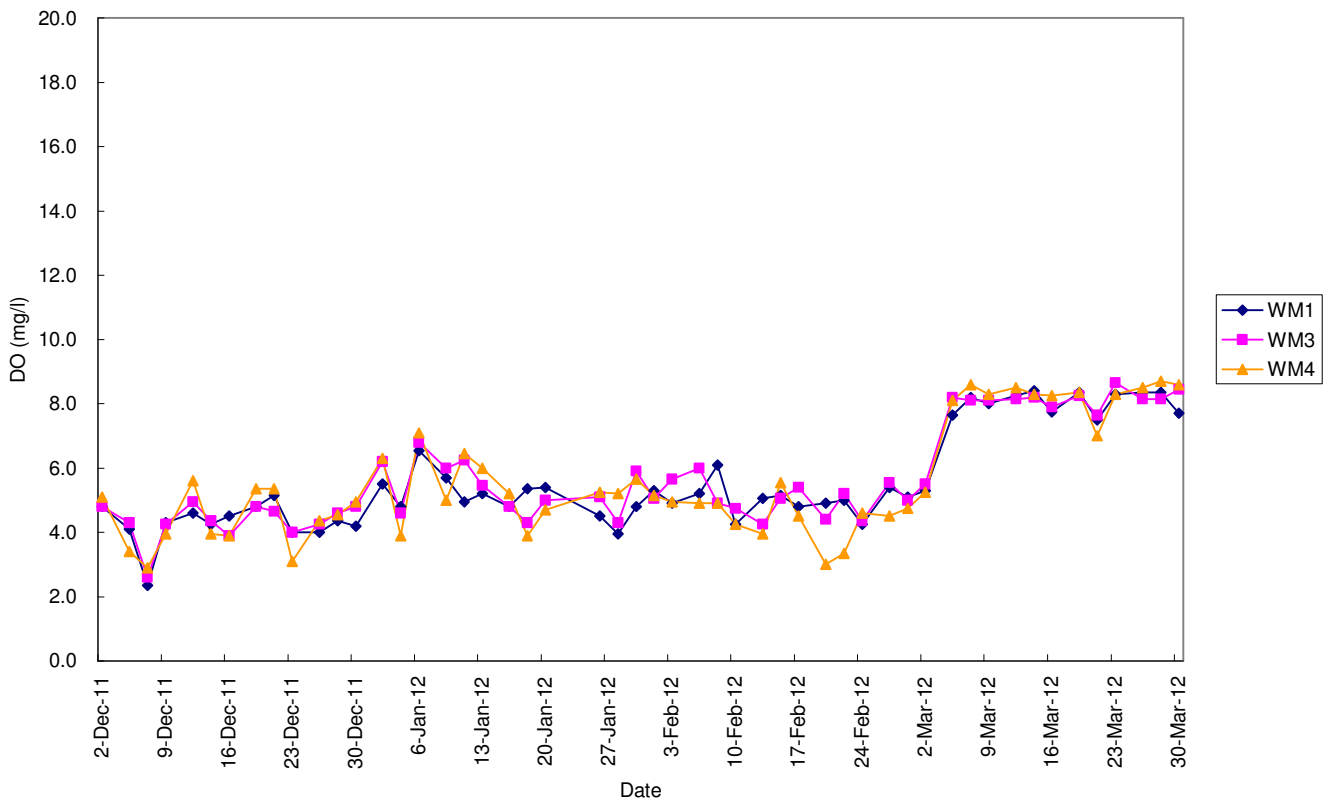

## Graphical Plots of Water Quality Monitoring Results

### Monitoring Results for Dissolved Oxygen in Flood Tide - Bottom Level

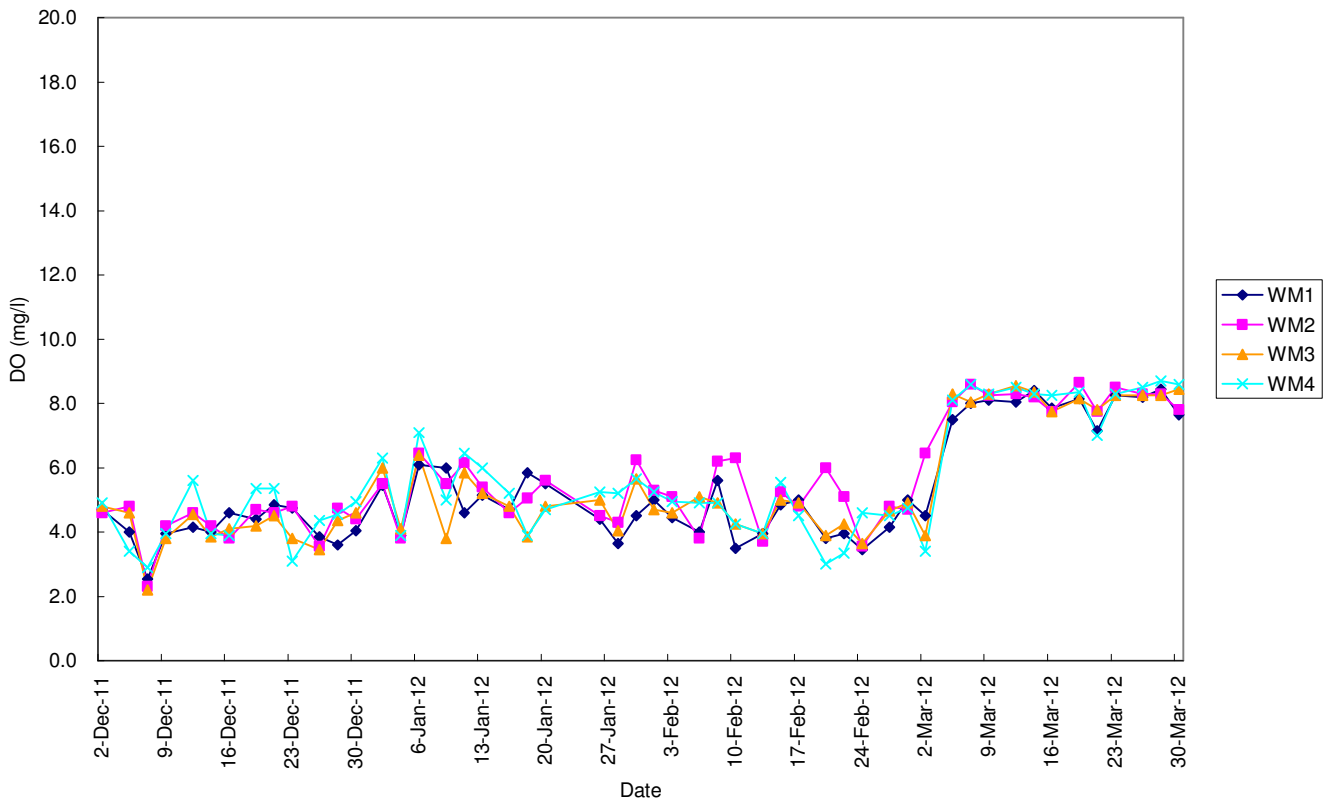

### Monitoring Results for Turbidity in Flood Tide - Depth Average

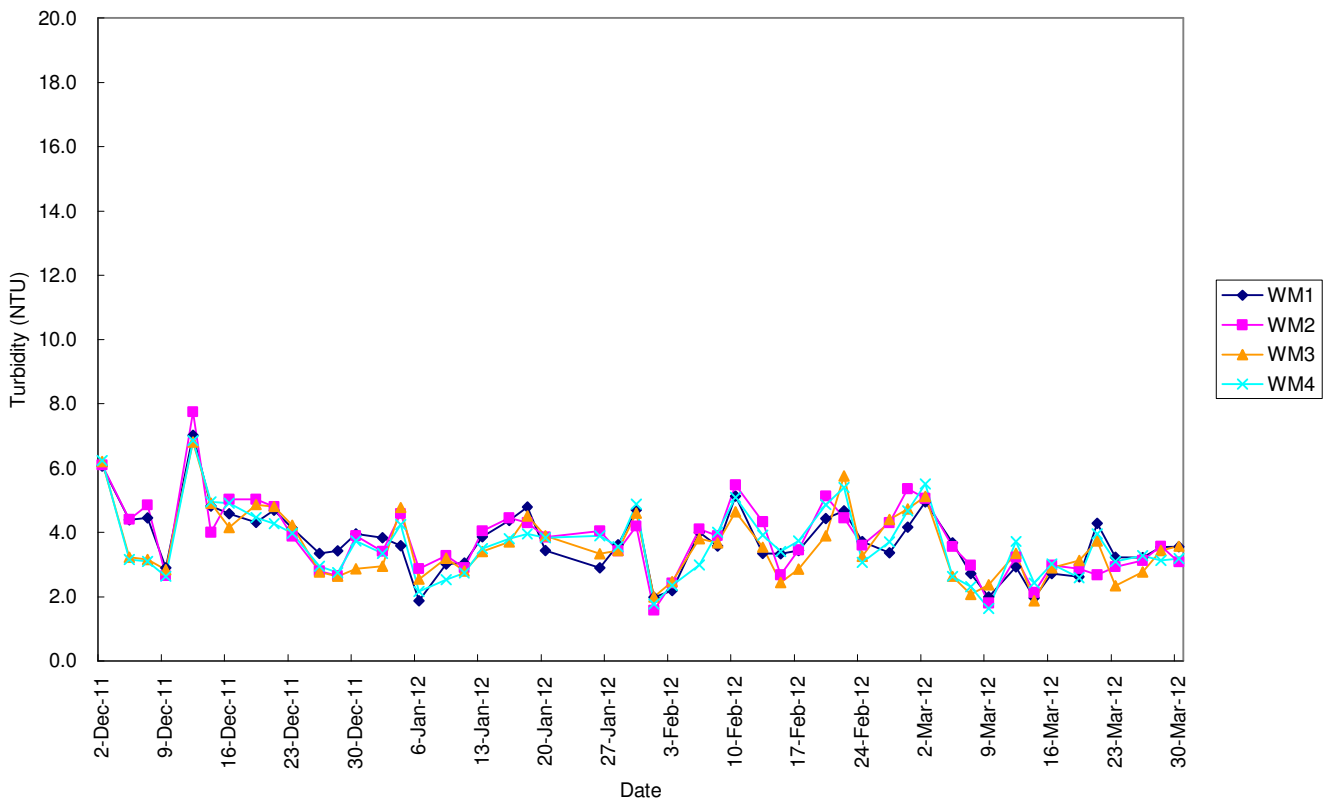

## Graphical Plots of Water Quality Monitoring Results

### Monitoring Results for Suspended Solids in Flood Tide - Depth Average

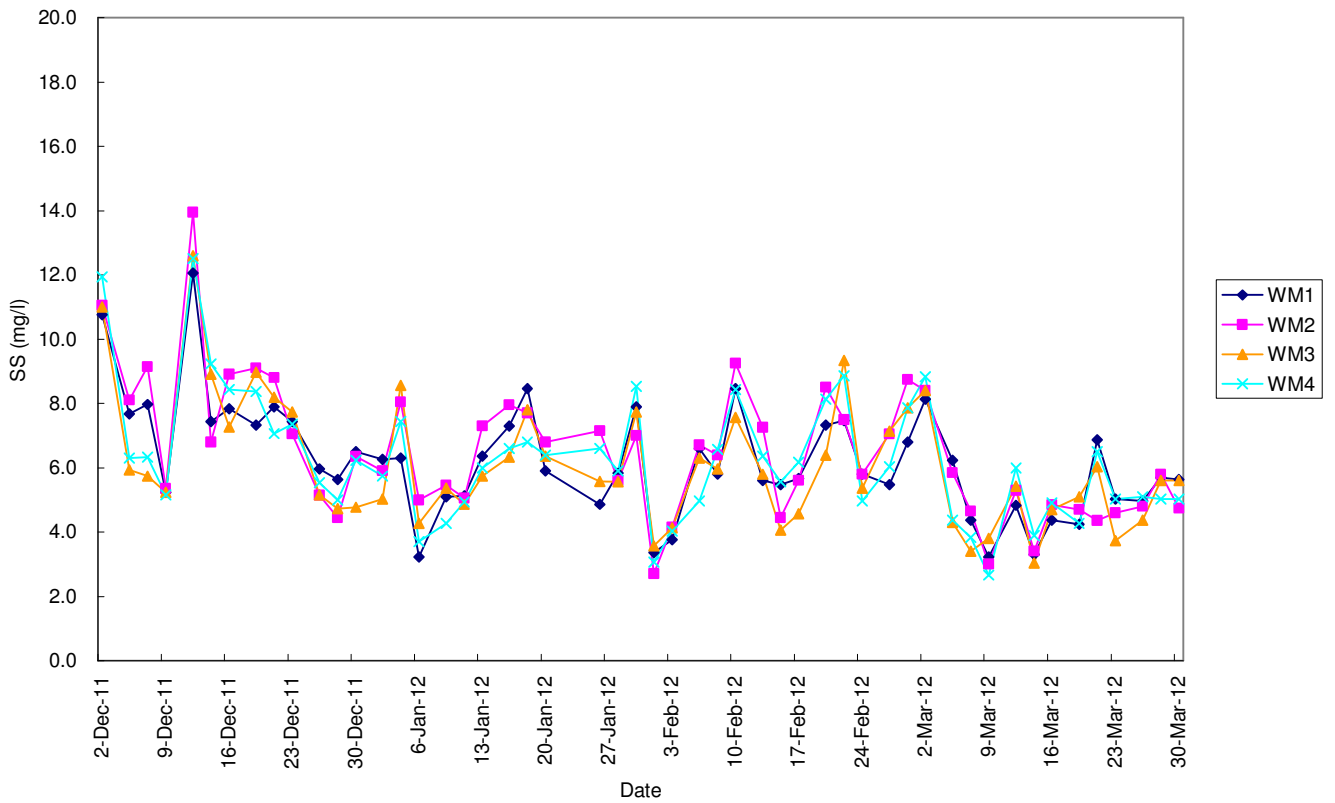

### Monitoring Results for Dissolved Oxygen in Ebb Tide - Surface Level

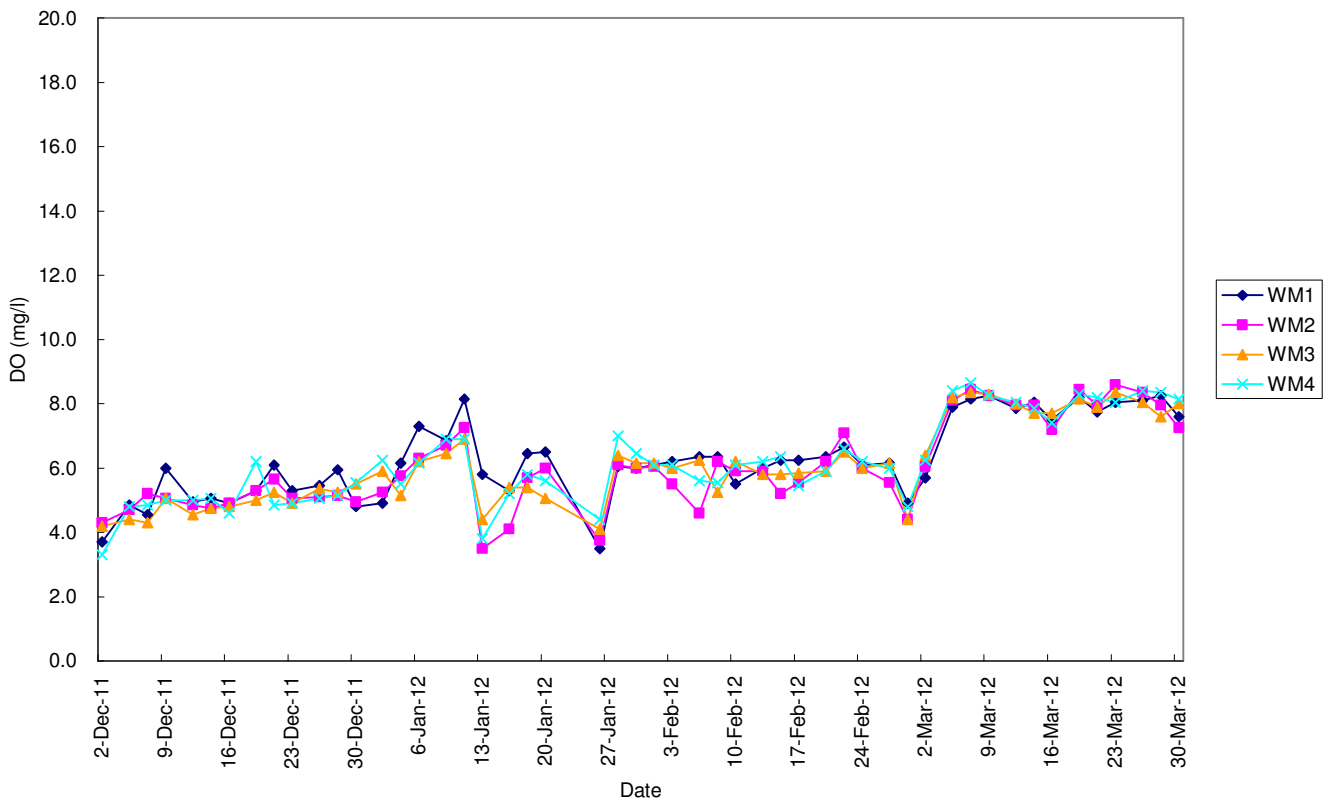

## Graphical Plots of Water Quality Monitoring Results

### Monitoring Results for Dissolved Oxygen in Ebb Tide - Middle Level

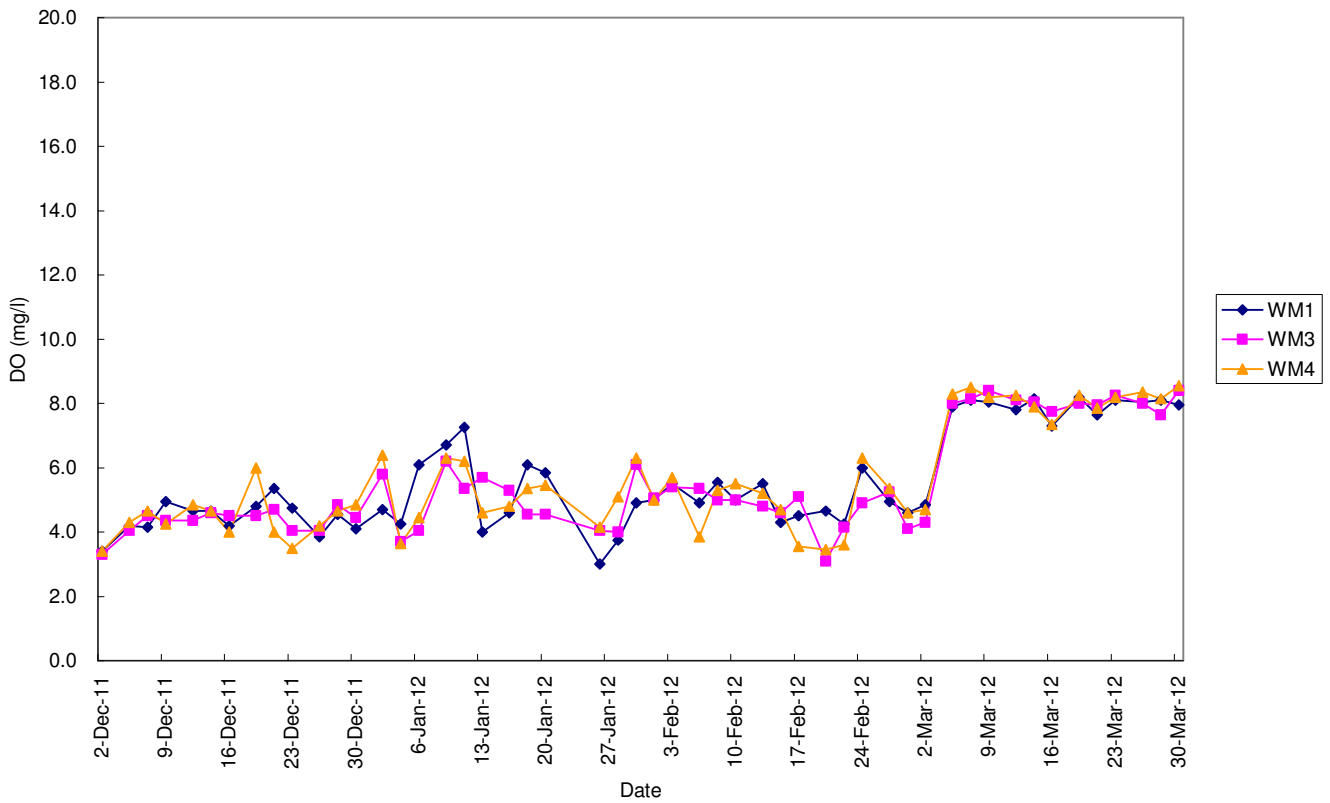

### Monitoring Results for Dissolved Oxygen in Ebb Tide - Bottom Level

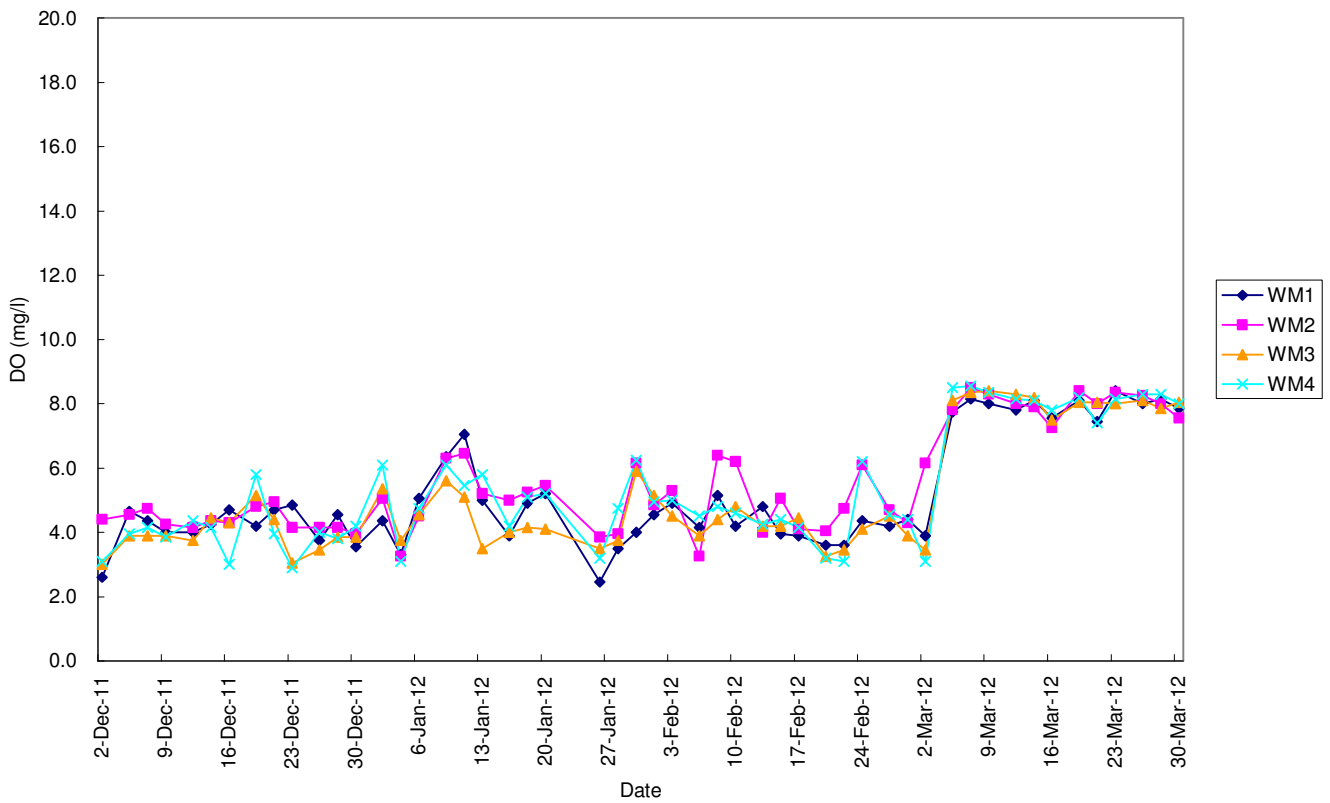

# Graphical Plots of Water Quality Monitoring Results

## Monitoring Results for Turbidity in Ebb Tide - Depth Average

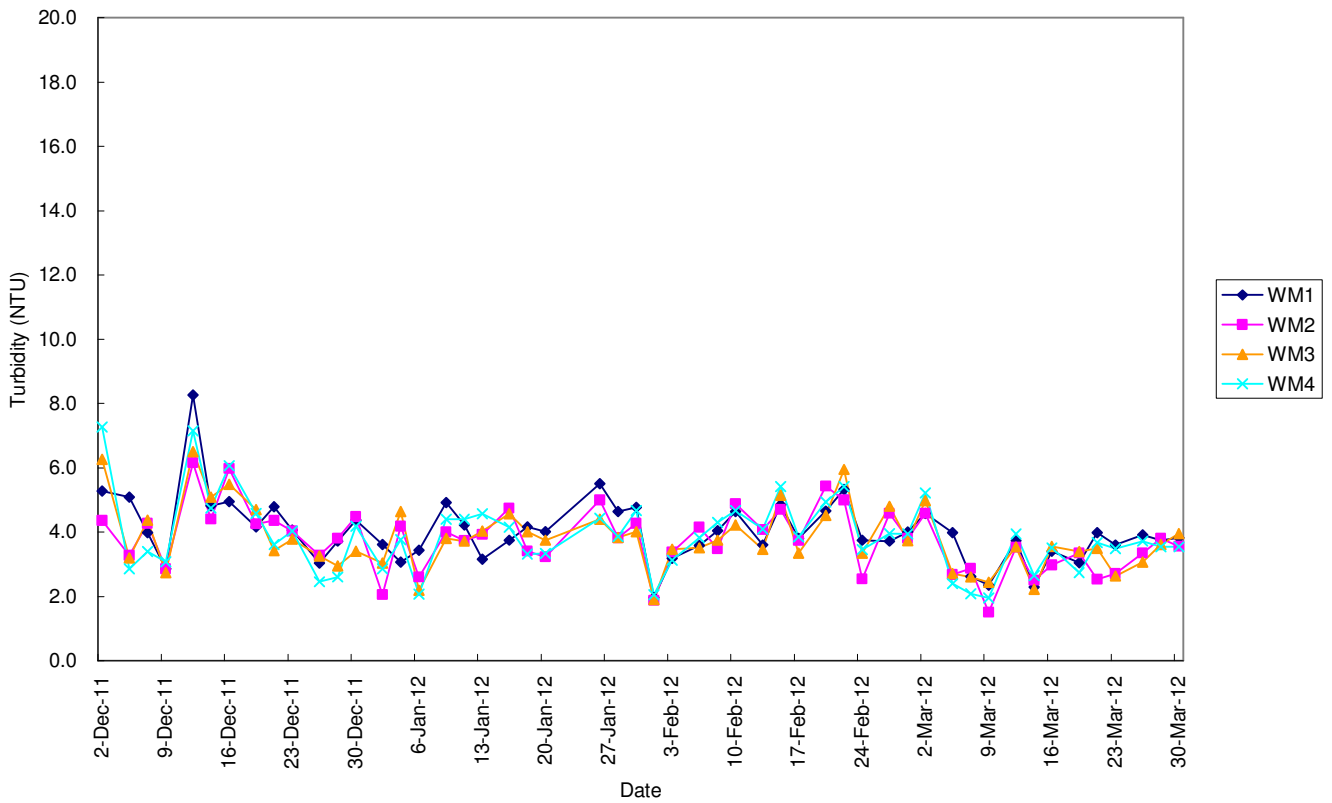

## Monitoring Results for Suspended Solids in Ebb Tide - Depth Average

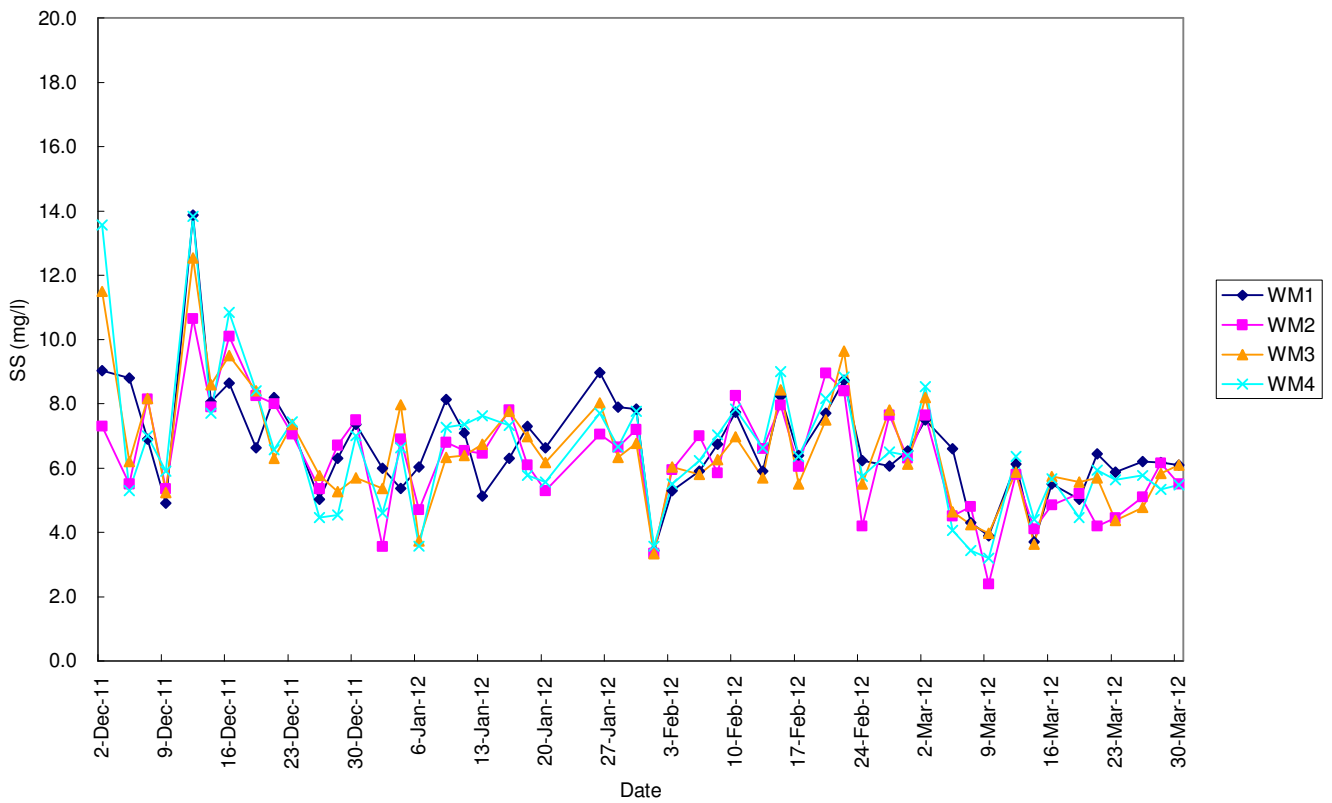

**SIL(E) Water Quality Monitoring Data Record Sheet**

Date: 2-Mar-12  
 Tide: Mid-Flood  
 Weather: Fine  
 Sea Conditions: Small Wave  
 Upstream Control Station:CS2

Location	Sampling Time	Water Depth (m)	Monitoring Depth	Temperature (°C)			pH			Salinity (ppt)			DO (mg/l)			DO Saturation (%)			Turbidity (NTU)				Suspended Solids (mg/l)							
				1	2	Ave.*	1	2	Ave.*	1	2	Ave.*	1	2	Ave.*	1	2	Ave.*	1	2	Ave.*	D.A.**	1	2	Ave.*	D.A.**				
CS1	1039	13.8	Surface	16.6	16.7	16.7	8.2	8.2	8.2	29.4	29.4	29.4	7.4	7.2	7.3	93.0	91.6	92.3	5.0	5.3	5.2					8.0	8.6	8.3		
			Middle	17.3	17.3	17.3	8.1	8.2	8.2	29.3	29.4	29.4	5.0	4.8	4.9	63.8	61.3	62.6	5.9	6.3	6.1	6.0					9.8	10.2	10.0	9.8
			Bottom	17.3	17.4	17.4	8.2	8.1	8.2	29.6	29.5	29.6	3.6	3.4	3.5	45.2	43.1	44.2	6.8	6.7	6.8					11.2	10.8	11.0		
WM1	0957	12.7	Surface	16.1	16.1	16.1	8.2	8.2	8.2	29.4	29.4	29.4	6.4	6.8	6.6	80.1	84.5	82.3	4.1	4.4	4.3					6.6	7.2	6.9		
			Middle	17.0	17.1	17.1	8.1	8.2	8.2	29.4	29.4	29.4	5.1	5.5	5.3	63.0	67.3	65.2	4.8	4.8	4.8	5.0					7.6	8.0	7.8	8.1
			Bottom	17.5	17.5	17.5	8.1	8.2	8.2	29.6	29.5	29.6	4.4	4.6	4.5	55.9	57.5	56.7	5.7	5.9	5.8					9.6	9.8	9.7		
WM2	0929	5.8	Surface	16.3	16.3	16.3	8.2	8.2	8.2	28.9	29.0	29.0	6.6	6.7	6.7	82.3	83.8	83.1	4.5	4.9	4.7					7.6	8.2	7.9		
			Middle																			5.1							8.4	
			Bottom	16.6	16.6	16.6	8.1	8.2	8.2	29.4	29.4	29.4	6.6	6.3	6.5	82.7	79.1	80.9	5.5	5.3	5.4					9.2	8.6	8.9		
WM3	0857	9.6	Surface	16.2	16.2	16.2	8.1	8.2	8.2	29.2	29.2	29.2	6.9	6.8	6.9	86.7	85.1	85.9	4.3	4.7	4.5					6.8	7.6	7.2		
			Middle	16.7	16.8	16.8	8.1	8.2	8.2	29.3	29.3	29.3	5.6	5.4	5.5	70.5	68.7	69.6	5.0	5.0	5.0	5.1					8.2	8.4	8.3	8.4
			Bottom	16.7	16.7	16.7	8.1	8.1	8.1	29.3	29.3	29.3	3.7	4.1	3.9	46.7	50.4	48.6	5.7	6.0	5.9					9.6	9.8	9.7		
WM4	0826	9.8	Surface	16.3	16.4	16.4	8.2	8.2	8.2	29.3	29.4	29.4	6.7	6.5	6.6	84.3	82.3	83.3	4.8	4.8	4.8					7.4	7.4	7.4		
			Middle	16.6	16.6	16.6	8.2	8.2	8.2	29.4	29.3	29.4	5.1	5.4	5.3	64.8	67.7	66.3	5.6	5.4	5.5	5.5					9.0	8.8	8.9	8.8
			Bottom	16.6	16.7	16.7	8.1	8.2	8.2	29.3	29.4	29.4	3.4	3.4	3.4	42.2	42.9	42.6	6.1	6.3	6.2					10.0	10.4	10.2		
CS2	0800	14.6	Surface	16.3	16.3	16.3	8.1	8.1	8.1	29.4	29.4	29.4	8.3	8.2	8.3	103.4	102.2	102.8	5.1	5.4	5.3					8.2	9.0	8.6		
			Middle	16.3	16.4	16.4	8.1	8.2	8.2	29.4	29.3	29.4	5.3	5.6	5.5	66.0	69.4	67.7	5.1	5.2	5.2	5.4					8.4	8.6	8.5	8.9
			Bottom	16.2	16.3	16.3	8.1	8.1	8.1	29.3	29.4	29.4	4.1	4.3	4.2	51.6	53.1	52.4	5.9	5.7	5.8					9.8	9.4	9.6		

Remark or Obsevation:

Note: \* Average

\*\* Depth Average

**SIL(E) Water Quality Monitoring Data Record Sheet**

Date: 2-Mar-12  
 Tide: Mid-Ebb  
 Weather: Fine  
 Sea Conditions: Small Wave  
 Upstream Control Station:CS1

Location	Sampling Time	Water Depth (m)	Monitoring Depth	Temperature (°C)			pH			Salinity (ppt)			DO (mg/l)			DO Saturation (%)			Turbidity (NTU)				Suspended Solids (mg/l)			
				1	2	Ave.*	1	2	Ave.*	1	2	Ave.*	1	2	Ave.*	1	2	Ave.*	1	2	Ave.*	D.A.**	1	2	Ave.*	D.A.**
CS1	1730	13.3	Surface	16.4	16.4	16.4	8.2	8.2	8.2	29.4	29.4	29.4	6.5	6.5	6.5	80.9	81.4	81.2	4.7	4.7	4.7	7.6	7.4	7.5		
			Middle	16.4	16.4	16.4	8.3	8.3	8.3	29.4	29.4	29.4	4.9	4.9	4.9	61.7	61.4	61.6	4.9	4.9	4.9	5.0	7.8	8.4	8.1	8.3
			Bottom	16.3	16.3	16.3	8.3	8.3	8.3	29.5	29.5	29.5	2.9	2.9	2.9	36.4	36.6	36.5	5.3	5.5	5.4	8.8	9.6	9.2		
WM1	1807	12.3	Surface	16.3	16.3	16.3	8.1	8.1	8.1	29.4	29.4	29.4	5.7	5.7	5.7	71.7	71.5	71.6	4.2	4.2	4.2	6.6	6.8	6.7		
			Middle	16.3	16.3	16.3	8.1	8.1	8.1	29.6	29.6	29.6	4.9	4.8	4.9	62.1	61.4	61.8	4.6	4.7	4.7	4.6	7.6	7.8	7.7	7.5
			Bottom	16.2	16.2	16.2	8.1	8.1	8.1	29.6	29.6	29.6	3.9	3.9	3.9	48.8	49.1	49.0	4.9	4.9	4.9	7.8	8.4	8.1		
WM2	1840	5.4	Surface	16.3	16.3	16.3	8.2	8.2	8.2	29.5	29.5	29.5	6.1	6.0	6.1	76.9	75.9	76.4	4.4	4.4	4.4	7.0	7.6	7.3		
			Middle																		4.6			7.7		
			Bottom	16.3	16.3	16.3	8.2	8.2	8.2	29.4	29.4	29.4	6.1	6.2	6.2	77.1	77.5	77.3	4.7	4.8	4.8	7.8	8.2	8.0		
WM3	1907	9.1	Surface	16.3	16.3	16.3	8.2	8.2	8.2	29.2	29.2	29.2	6.4	6.4	6.4	80.9	79.8	80.4	4.4	4.7	4.6	7.0	7.8	7.4		
			Middle	16.2	16.2	16.2	8.2	8.2	8.2	29.3	29.3	29.3	4.3	4.3	4.3	54.2	54.4	54.3	5.1	4.9	5.0	5.0	8.4	8.0	8.2	8.2
			Bottom	16.1	16.1	16.1	8.1	8.1	8.1	29.3	29.3	29.3	3.4	3.5	3.5	42.7	43.2	43.0	5.3	5.5	5.4	8.6	9.4	9.0		
WM4	1938	9.2	Surface	16.3	16.3	16.3	8.3	8.3	8.3	29.4	29.4	29.4	6.3	6.2	6.3	79.1	78.7	78.9	4.8	4.8	4.8	8.2	7.8	8.0		
			Middle	16.2	16.2	16.2	8.2	8.2	8.2	29.3	29.3	29.3	4.7	4.7	4.7	58.4	58.8	58.6	5.2	5.3	5.3	5.2	8.6	9.0	8.8	8.5
			Bottom	16.4	16.4	16.4	8.2	8.2	8.2	29.4	29.4	29.4	3.1	3.1	3.1	39.2	38.7	39.0	5.6	5.6	5.6	8.6	9.0	8.8		
CS2	2010	14.1	Surface	16.4	16.4	16.4	8.1	8.1	8.1	29.4	29.4	29.4	7.1	7.1	7.1	88.9	88.4	88.7	4.6	4.6	4.6	7.2	7.6	7.4		
			Middle	16.3	16.3	16.3	8.1	8.1	8.1	29.3	29.3	29.3	3.9	3.8	3.9	48.4	48.8	48.6	5.1	5.1	5.1	5.1	8.4	8.4	8.4	8.2
			Bottom	16.3	16.3	16.3	8.2	8.2	8.2	29.3	29.3	29.3	3.5	3.5	3.5	44.1	43.6	43.9	5.5	5.5	5.5	9.0	8.6	8.8		

Remark or Observation:

Note: \* Average

\*\* Depth Average

**SIL(E) Water Quality Monitoring Data Record Sheet**

Date: 5-Mar-12  
 Tide: Mid-Flood  
 Weather: Fine  
 Sea Conditions: Clam  
 Upstream Control Station:CS2

Location	Sampling Time	Water Depth (m)	Monitoring Depth	Temperature (°C)			pH			Salinity (ppt)			DO (mg/l)			DO Saturation (%)			Turbidity (NTU)				Suspended Solids (mg/l)							
				1	2	Ave.*	1	2	Ave.*	1	2	Ave.*	1	2	Ave.*	1	2	Ave.*	1	2	Ave.*	D.A.**	1	2	Ave.*	D.A.**				
CS1	1542	12.3	Surface	16.3	16.4	16.4	8.1	8.2	8.2	27.8	27.9	27.9	8.9	8.8	8.9	107.4	106.1	106.8	7.6	7.8	7.7					12.2	12.8	12.5		
			Middle	16.4	16.4	16.4	8.1	8.1	8.1	27.9	27.9	27.9	8.5	8.5	8.5	102.0	102.7	102.4	4.1	4.2	4.2	5.5					6.8	6.6	6.7	8.9
			Bottom	15.9	15.9	15.9	8.1	8.1	8.1	28.0	27.9	28.0	8.7	8.7	8.7	105.8	104.3	105.1	4.5	4.7	4.6					7.4	7.6	7.5		
WM1	1512	15.3	Surface	16.5	16.5	16.5	8.2	8.1	8.2	28.0	28.0	28.0	8.1	8.1	8.1	98.9	98.4	98.7	4.7	4.7	4.7					6.8	6.6	6.7		
			Middle	16.2	16.3	16.3	8.2	8.2	8.2	27.9	28.0	28.0	7.6	7.7	7.7	91.6	92.9	92.3	3.7	3.6	3.7	3.7					6.4	6.6	6.5	6.2
			Bottom	16.1	16.1	16.1	8.1	8.2	8.2	28.1	28.1	28.1	7.4	7.6	7.5	89.1	91.3	90.2	2.5	2.8	2.7					5.4	5.6	5.5		
WM2	1449	5.7	Surface	16.4	16.5	16.5	8.2	8.1	8.2	28.0	28.0	28.0	8.1	8.0	8.1	98.2	97.0	97.6	3.5	3.7	3.6					5.6	6.0	5.8		
			Middle																			3.6							5.9	
			Bottom	16.4	16.4	16.4	8.2	8.2	8.2	28.0	28.1	28.1	7.9	8.2	8.1	96.5	99.9	98.2	3.5	3.5	3.5					5.8	6.0	5.9		
WM3	1422	10.5	Surface	16.4	16.3	16.4	8.2	8.3	8.3	28.1	28.1	28.1	8.5	8.5	8.5	102.2	101.6	101.9	2.4	2.6	2.5					3.8	4.2	4.0		
			Middle	16.2	16.2	16.2	8.3	8.2	8.3	28.1	28.1	28.1	8.1	8.3	8.2	98.3	100.4	99.4	2.2	2.4	2.3	2.6					3.6	4.0	3.8	4.3
			Bottom	16.0	15.9	16.0	8.3	8.3	8.3	28.2	28.1	28.2	8.3	8.3	8.3	100.1	100.8	100.5	3.1	3.1	3.1					5.0	5.2	5.1		
WM4	1355	10.6	Surface	16.4	16.4	16.4	8.3	8.2	8.3	28.1	28.0	28.1	8.6	8.8	8.7	104.7	106.7	105.7	2.5	2.5	2.5					4.0	4.0	4.0		
			Middle	16.2	16.3	16.3	8.2	8.2	8.2	28.0	28.1	28.1	8.3	8.4	8.4	101.0	102.6	101.8	2.5	2.6	2.6	2.6					4.2	4.2	4.2	4.4
			Bottom	15.8	15.9	15.9	8.2	8.3	8.3	28.2	28.2	28.2	8.1	8.1	8.1	98.9	97.3	98.1	2.8	2.9	2.9					4.8	5.0	4.9		
CS2	1330	15.2	Surface	16.5	16.6	16.6	8.3	8.3	8.3	28.0	28.1	28.1	8.2	8.3	8.3	99.5	100.8	100.2	3.4	3.4	3.4					5.6	5.4	5.5		
			Middle	15.6	15.5	15.6	8.2	8.3	8.3	28.4	28.4	28.4	8.7	8.9	8.8	105.2	107.4	106.3	4.6	4.4	4.5	4.2					7.6	7.2	7.4	6.8
			Bottom	15.6	15.6	15.6	8.3	8.3	8.3	28.6	28.6	28.6	8.4	8.3	8.4	101.6	100.5	101.1	4.6	4.6	4.6					7.6	7.6	7.6		

Remark or Observation:

Note: \* Average

\*\* Depth Average

**SIL(E) Water Quality Monitoring Data Record Sheet**

Date: 5-Mar-12  
 Tide: Mid-Ebb  
 Weather: Fine  
 Sea Conditions: Calm  
 Upstream Control Station:CS1

Location	Sampling Time	Water Depth (m)	Monitoring Depth	Temperature (°C)			pH			Salinity (ppt)			DO (mg/l)			DO Saturation (%)			Turbidity (NTU)				Suspended Solids (mg/l)						
				1	2	Ave.*	1	2	Ave.*	1	2	Ave.*	1	2	Ave.*	1	2	Ave.*	1	2	Ave.*	D.A.**	1	2	Ave.*	D.A.**			
CS1	900	11.7	Surface	16.3	16.3	16.3	8.1	8.1	8.1	27.8	27.8	27.8	8.6	8.6	8.6	104.4	104.1	104.3	8.3	8.3	8.3					13.2	14.0	13.6	
			Middle	16.3	16.3	16.3	8.1	8.1	8.1	27.9	27.9	27.9	8.6	8.5	8.6	104.1	103.6	103.9	4.6	4.6	4.6	6.3				7.6	7.4	7.5	10.4
			Bottom	15.9	16.0	16.0	8.1	8.1	8.1	28.0	28.0	28.0	8.5	8.5	8.5	103.2	103.6	103.4	5.8	5.9	5.9					9.8	10.2	10.0	
WM1	928	14.9	Surface	16.4	16.4	16.4	8.2	8.2	8.2	27.9	28.0	28.0	7.9	7.9	7.9	96.7	96.1	96.4	5.2	5.2	5.2					8.4	8.6	8.5	
			Middle	16.2	16.2	16.2	8.2	8.2	8.2	28.0	28.0	28.0	7.9	7.9	7.9	46.0	45.8	45.9	3.9	3.9	3.9	4.0				6.4	6.2	6.3	6.6
			Bottom	16.1	16.1	16.1	8.2	8.2	8.2	28.0	28.0	28.0	7.8	7.7	7.8	93.9	93.5	93.7	2.8	2.9	2.9					4.8	5.2	5.0	
WM2	953	5.2	Surface	16.4	16.4	16.4	8.2	8.2	8.2	28.0	28.0	28.0	8.1	8.1	8.1	98.3	98.0	98.2	3.1	3.2	3.2					5.2	5.4	5.3	
			Middle																			2.7						4.5	
			Bottom	16.3	16.3	16.3	8.2	8.2	8.2	28.0	28.0	28.0	7.8	7.8	7.8	94.8	94.4	94.6	2.2	2.2	2.2					3.6	3.8	3.7	
WM3	1017	10.0	Surface	16.3	16.3	16.3	8.3	8.3	8.3	28.0	28.0	28.0	8.2	8.2	8.2	99.7	99.2	99.5	2.7	2.8	2.8					4.6	4.6	4.6	
			Middle	16.2	16.2	16.2	8.3	8.3	8.3	28.1	28.1	28.1	8.0	8.0	8.0	97.1	96.8	97.0	2.0	2.0	2.0	2.7				3.4	3.6	3.5	4.6
			Bottom	16.0	16.0	16.0	8.3	8.3	8.3	28.2	28.2	28.2	8.1	8.1	8.1	97.8	98.3	98.1	3.3	3.4	3.4					6.0	5.6	5.8	
WM4	1043	10.3	Surface	16.4	16.4	16.4	8.3	8.2	8.3	28.1	28.1	28.1	8.4	8.4	8.4	102.1	102.4	102.3	2.7	2.7	2.7					4.4	4.6	4.5	
			Middle	16.2	16.2	16.2	8.3	8.3	8.3	28.1	28.1	28.1	8.3	8.3	8.3	101.1	100.8	101.0	1.8	1.8	1.8	2.4				3.0	3.4	3.2	4.1
			Bottom	15.9	15.9	15.9	8.3	8.3	8.3	28.2	28.2	28.2	8.5	8.5	8.5	102.7	102.9	102.8	2.7	2.7	2.7					4.4	4.6	4.5	
CS2	1111	14.8	Surface	16.5	16.5	16.5	8.2	8.2	8.2	28.1	28.1	28.1	8.5	8.5	8.5	104.3	104.7	104.5	3.0	3.0	3.0					5.0	5.2	5.1	
			Middle	15.6	15.6	15.6	8.2	8.3	8.3	28.4	28.4	28.4	8.8	8.8	8.8	105.9	105.4	105.7	4.1	4.1	4.1	3.7				7.0	7.0	7.0	6.2
			Bottom	15.6	15.6	15.6	8.3	8.3	8.3	28.6	28.6	28.6	8.6	8.6	8.6	103.8	104.3	104.1	3.9	4.0	4.0					6.2	6.6	6.4	

Remark or Observation:

Note: \* Average

\*\* Depth Average

**SIL(E) Water Quality Monitoring Data Record Sheet**

Date: 7-Mar-12  
 Tide: Mid-Flood  
 Weather: Cloudy  
 Sea Conditions: Small Wave  
 Upstream Control Station:CS2

Location	Sampling Time	Water Depth (m)	Monitoring Depth	Temperature (°C)			pH			Salinity (ppt)			DO (mg/l)			DO Saturation (%)			Turbidity (NTU)				Suspended Solids (mg/l)			
				1	2	Ave.*	1	2	Ave.*	1	2	Ave.*	1	2	Ave.*	1	2	Ave.*	1	2	Ave.*	D.A.**	1	2	Ave.*	D.A.**
CS1	1738	12.8	Surface	16.8	16.8	16.8	8.1	8.1	8.1	26.9	27.0	27.0	9.2	9.2	9.2	110.4	110.6	110.5	3.0	2.4	2.7		4.8	4.0	4.4	
			Middle	16.5	16.6	16.6	8.2	8.1	8.2	27.0	27.0	27.0	8.8	8.8	8.8	105.6	105.2	105.4	2.4	2.2	2.3	2.5	4.0	3.6	3.8	4.1
			Bottom	16.8	16.7	16.8	8.2	8.2	8.2	26.8	26.9	26.9	8.2	8.2	8.2	98.4	98.0	98.2	2.6	2.2	2.4		4.4	3.6	4.0	
WM1	1658	15.0	Surface	17.0	17.1	17.1	8.2	8.1	8.2	27.1	27.2	27.2	8.4	8.8	8.6	100.1	105.5	102.8	3.3	3.4	3.4		5.0	5.4	5.2	
			Middle	17.0	16.9	17.0	8.1	8.1	8.1	27.1	27.1	27.1	8.2	8.2	8.2	98.4	98.6	98.5	2.6	2.8	2.7	2.7	4.2	4.6	4.4	4.4
			Bottom	16.9	16.9	16.9	8.2	8.2	8.2	27.0	27.1	27.1	8.0	8.0	8.0	96.2	96.3	96.3	2.2	2.0	2.1		3.8	3.2	3.5	
WM2	1632	5.8	Surface	17.1	17.1	17.1	8.2	8.1	8.2	27.2	27.2	27.2	8.4	8.4	8.4	100.8	100.2	100.5	3.4	3.6	3.5		5.0	5.4	5.2	
			Middle																		3.0				4.7	
			Bottom	16.9	16.9	16.9	8.1	8.1	8.1	27.0	27.0	27.0	8.6	8.6	8.6	103.2	103.4	103.3	2.8	2.1	2.5		4.6	3.6	4.1	
WM3	1603	10.0	Surface	16.9	16.9	16.9	8.2	8.2	8.2	27.3	27.3	27.3	8.4	8.4	8.4	100.8	100.6	100.7	1.5	1.1	1.3		2.4	1.8	2.1	
			Middle	16.7	16.7	16.7	8.1	8.1	8.1	27.2	27.3	27.3	8.1	8.1	8.1	97.2	97.8	97.5	2.5	2.3	2.4	2.1	4.2	3.6	3.9	3.4
			Bottom	16.9	16.8	16.9	8.2	8.1	8.2	27.0	27.1	27.1	8.0	8.1	8.1	96.2	97.0	96.6	2.8	2.2	2.5		4.8	3.6	4.2	
WM4	1534	11.0	Surface	17.0	17.0	17.0	8.1	8.1	8.1	27.2	27.2	27.2	8.9	8.9	8.9	106.8	106.7	106.8	2.4	2.0	2.2		3.8	3.4	3.6	
			Middle	16.9	16.9	16.9	8.2	8.2	8.2	27.3	27.2	27.3	8.4	8.5	8.5	100.5	100.3	100.4	2.7	2.3	2.5	2.3	4.6	3.8	4.2	3.8
			Bottom	16.7	16.8	16.8	8.2	8.1	8.2	27.2	27.1	27.2	8.6	8.6	8.6	103.2	103.6	103.4	2.1	2.3	2.2		3.6	3.8	3.7	
CS2	1500	15.0	Surface	17.1	17.1	17.1	8.2	8.2	8.2	27.4	27.4	27.4	9.0	9.1	9.1	107.2	108.0	107.6	2.0	2.8	2.4		3.4	4.8	4.1	
			Middle	16.8	16.9	16.9	8.2	8.1	8.2	27.5	27.4	27.5	8.9	9.0	9.0	106.1	106.9	106.5	2.4	2.6	2.5	2.5	4.0	4.4	4.2	4.2
			Bottom	16.6	16.6	16.6	8.1	8.2	8.2	27.3	27.3	27.3	8.8	8.8	8.8	105.6	105.4	105.5	2.4	2.6	2.5		4.2	4.6	4.4	

Remark or Observation:

Note: \* Average

\*\* Depth Average

**SIL(E) Water Quality Monitoring Data Record Sheet**

Date: 7-Mar-12  
 Tide: Mid-Ebb  
 Weather: Cloudy  
 Sea Conditions: Small Wave  
 Upstream Control Station:CS1

Location	Sampling Time	Water Depth (m)	Monitoring Depth	Temperature (°C)			pH			Salinity (ppt)			DO (mg/l)			DO Saturation (%)			Turbidity (NTU)				Suspended Solids (mg/l)							
				1	2	Ave.*	1	2	Ave.*	1	2	Ave.*	1	2	Ave.*	1	2	Ave.*	1	2	Ave.*	D.A.**	1	2	Ave.*	D.A.**				
CS1	1030	12.0	Surface	16.6	16.7	16.7	8.1	8.0	8.1	26.8	26.9	26.9	9.0	8.9	9.0	107.2	106.5	106.9	3.4	3.6	3.5					5.8	5.8	5.8		
			Middle	16.6	16.6	16.6	8.1	8.1	8.1	26.9	26.9	26.9	8.9	8.8	8.9	106.1	104.7	105.4	2.9	2.8	2.9	2.9					5.0	4.8	4.9	4.9
			Bottom	16.6	16.7	16.7	8.1	8.2	8.2	27.0	26.9	27.0	8.5	8.4	8.5	101.4	100.4	100.9	2.2	2.5	2.4					3.8	4.2	4.0		
WM1	1102	14.8	Surface	16.9	16.8	16.9	8.1	8.2	8.2	27.0	27.0	27.0	8.2	8.1	8.2	98.5	97.2	97.9	2.9	3.1	3.0					4.6	5.2	4.9		
			Middle	16.8	16.8	16.8	8.1	8.1	8.1	27.0	27.0	27.0	8.1	8.1	8.1	96.3	97.0	96.7	2.1	2.4	2.3	2.6					3.4	4.0	3.7	4.3
			Bottom	16.8	16.7	16.8	8.1	8.2	8.2	27.0	27.0	27.0	8.2	8.1	8.2	97.6	97.2	97.4	2.4	2.8	2.6					4.0	4.6	4.3		
WM2	1128	5.6	Surface	16.8	16.8	16.8	8.2	8.2	8.2	27.1	27.1	27.1	8.5	8.4	8.5	101.5	100.5	101.0	3.4	3.0	3.2					5.8	4.8	5.3		
			Middle																			2.9							4.8	
			Bottom	16.8	16.8	16.8	8.2	8.2	8.2	27.0	27.1	27.1	8.5	8.5	8.5	101.5	102.2	101.9	2.4	2.7	2.6					4.0	4.6	4.3		
WM3	1153	9.6	Surface	16.8	16.8	16.8	8.1	8.2	8.2	27.1	27.1	27.1	8.3	8.4	8.4	99.3	100.6	100.0	1.9	2.2	2.1					3.0	3.6	3.3		
			Middle	16.8	16.7	16.8	8.2	8.2	8.2	27.2	27.1	27.2	8.2	8.1	8.2	97.9	97.2	97.6	2.8	2.5	2.7	2.6					4.6	4.0	4.3	4.2
			Bottom	16.8	16.8	16.8	8.2	8.1	8.2	27.1	27.1	27.1	8.4	8.3	8.4	100.3	94.4	97.4	2.9	3.3	3.1					4.8	5.4	5.1		
WM4	1220	10.6	Surface	16.9	16.9	16.9	8.1	8.2	8.2	27.1	27.1	27.1	8.7	8.6	8.7	104.2	103.1	103.7	2.0	2.1	2.1					3.2	3.4	3.3		
			Middle	16.8	16.9	16.9	8.2	8.1	8.2	27.2	27.1	27.2	8.5	8.5	8.5	101.2	102.1	101.7	1.8	1.5	1.7	2.1					3.0	2.6	2.8	3.4
			Bottom	16.8	16.8	16.8	8.2	8.2	8.2	27.2	27.2	27.2	8.6	8.5	8.6	102.8	101.5	102.2	2.4	2.7	2.6					4.0	4.4	4.2		
CS2	1245	14.8	Surface	17.0	17.0	17.0	8.2	8.2	8.2	27.2	27.2	27.2	9.3	9.2	9.3	110.7	109.9	110.3	1.1	1.3	1.2					1.8	2.2	2.0		
			Middle	16.8	16.8	16.8	8.1	8.2	8.2	27.3	27.4	27.4	9.0	9.1	9.1	107.9	108.5	108.2	1.7	1.5	1.6	1.6					2.8	2.4	2.6	2.6
			Bottom	16.7	16.7	16.7	8.1	8.1	8.1	27.3	27.4	27.4	9.0	9.0	9.0	107.4	107.0	107.2	2.0	1.8	1.9					3.2	3.0	3.1		

Remark or Observation:

Note: \* Average

\*\* Depth Average

**SIL(E) Water Quality Monitoring Data Record Sheet**

Date: 9-Mar-12  
 Tide: Mid-Flood  
 Weather: Cloudy  
 Sea Conditions: Small Wave  
 Upstream Control Station:CS2

Location	Sampling Time	Water Depth (m)	Monitoring Depth	Temperature (°C)			pH			Salinity (ppt)			DO (mg/l)			DO Saturation (%)			Turbidity (NTU)				Suspended Solids (mg/l)			
				1	2	Ave.*	1	2	Ave.*	1	2	Ave.*	1	2	Ave.*	1	2	Ave.*	1	2	Ave.*	D.A.**	1	2	Ave.*	D.A.**
CS1	1855	11.8	Surface	16.6	16.5	16.6	8.2	8.2	8.2	27.3	27.3	27.3	8.5	8.6	8.6	102.0	103.2	102.6	3.4	3.2	3.3		5.2	5.0	5.1	
			Middle	16.5	16.5	16.5	8.3	8.2	8.3	27.1	27.2	27.2	8.5	8.3	8.4	102.4	99.8	101.1	4.5	4.2	4.4	4.3	7.2	6.8	7.0	6.8
			Bottom	16.3	16.4	16.4	8.3	8.2	8.3	27.3	27.3	27.3	8.1	8.2	8.2	97.2	98.4	97.8	5.4	5.0	5.2		8.8	8.0	8.4	
WM1	1823	17.0	Surface	16.5	16.5	16.5	8.2	8.3	8.3	27.3	27.3	27.3	8.3	8.3	8.3	99.6	99.4	99.5	1.8	1.4	1.6		3.0	2.4	2.7	
			Middle	16.5	16.5	16.5	8.2	8.1	8.2	27.1	27.1	27.1	8.0	8.0	8.0	96.4	96.6	96.5	2.0	2.2	2.1	2.0	3.4	3.0	3.2	3.2
			Bottom	16.4	16.5	16.5	8.3	8.3	8.3	27.2	27.2	27.2	8.1	8.1	8.1	97.2	97.0	97.1	2.4	2.2	2.3		4.0	3.6	3.8	
WM2	1810	5.8	Surface	16.5	16.5	16.5	8.1	8.1	8.1	27.4	27.3	27.4	8.2	8.2	8.2	99.2	99.8	99.5	2.1	2.3	2.2		3.4	3.8	3.6	
			Middle																		1.8				3.0	
			Bottom	16.4	16.3	16.4	8.2	8.2	8.2	27.2	27.3	27.3	8.2	8.3	8.3	98.4	99.6	99.0	1.5	1.3	1.4		2.6	2.2	2.4	
WM3	1739	10.6	Surface	16.5	16.6	16.6	8.3	8.2	8.3	27.2	27.2	27.2	8.2	8.2	8.2	100.1	100.9	100.5	2.9	2.1	2.5		4.4	3.2	3.8	
			Middle	16.4	16.5	16.5	8.3	8.2	8.3	27.3	27.4	27.4	8.1	8.1	8.1	97.2	97.6	97.4	2.2	2.6	2.4	2.4	3.8	4.2	4.0	3.8
			Bottom	16.6	16.5	16.6	8.2	8.2	8.2	27.5	27.4	27.5	8.3	8.3	8.3	99.6	99.4	99.5	2.3	2.1	2.2		3.8	3.4	3.6	
WM4	1709	10.8	Surface	16.5	16.6	16.6	8.2	8.2	8.2	27.5	27.4	27.5	8.4	8.4	8.4	100.8	100.2	100.5	2.2	2.4	2.3		3.4	4.0	3.7	
			Middle	16.4	16.5	16.5	8.3	8.2	8.3	27.3	27.4	27.4	8.1	8.1	8.1	97.2	97.6	97.4	1.2	1.0	1.1	1.6	2.0	1.6	1.8	2.7
			Bottom	16.6	16.5	16.6	8.2	8.2	8.2	27.5	27.4	27.5	8.3	8.3	8.3	99.6	99.4	99.5	1.3	1.7	1.5		2.2	2.8	2.5	
CS2	1615	15.4	Surface	16.6	16.5	16.6	8.2	8.3	8.3	27.4	27.4	27.4	9.0	9.0	9.0	108.1	108.3	108.2	1.9	1.8	1.9		3.2	3.0	3.1	
			Middle	16.4	16.3	16.4	8.2	8.2	8.2	27.5	27.4	27.5	8.9	8.9	8.9	106.8	106.2	106.5	2.5	2.3	2.4	2.5	4.2	4.0	4.1	4.1
			Bottom	16.3	16.3	16.3	8.1	8.2	8.2	27.6	27.5	27.6	9.0	8.9	9.0	108.5	107.3	107.9	3.0	3.2	3.1		5.0	5.4	5.2	

Remark or Observation:

Note: \* Average

\*\* Depth Average

**SIL(E) Water Quality Monitoring Data Record Sheet**

Date: 9-Mar-12  
 Tide: Mid-Ebb  
 Weather: Cloudy  
 Sea Conditions: Small Wave  
 Upstream Control Station:CS1

Location	Sampling Time	Water Depth (m)	Monitoring Depth	Temperature (°C)			pH			Salinity (ppt)			DO (mg/l)			DO Saturation (%)			Turbidity (NTU)				Suspended Solids (mg/l)			
				1	2	Ave.*	1	2	Ave.*	1	2	Ave.*	1	2	Ave.*	1	2	Ave.*	1	2	Ave.*	D.A.**	1	2	Ave.*	D.A.**
CS1	1130	11.3	Surface	16.5	16.5	16.5	8.2	8.3	8.3	27.1	27.1	27.1	8.7	8.5	8.6	104.9	102.4	103.7	4.8	5.0	4.9		7.4	8.0	7.7	
			Middle	16.5	16.5	16.5	8.3	8.3	8.3	27.2	27.2	27.2	8.6	8.6	8.6	103.3	103.8	103.6	5.7	5.7	5.7	5.6	9.4	9.6	9.5	9.0
			Bottom	16.5	16.4	16.5	8.2	8.3	8.3	27.3	27.2	27.3	8.5	8.3	8.4	102.6	100.7	101.7	6.0	6.1	6.1		9.6	9.8	9.7	
WM1	1205	16.4	Surface	16.6	16.5	16.6	8.2	8.2	8.2	27.2	27.2	27.2	8.4	8.1	8.3	101.3	98.0	99.7	1.4	1.4	1.4		2.2	2.4	2.3	
			Middle	16.6	16.6	16.6	8.3	8.2	8.3	27.2	27.3	27.3	8.0	8.1	8.1	97.0	98.4	97.7	2.4	2.6	2.5	2.4	4.0	4.4	4.2	3.9
			Bottom	16.6	16.6	16.6	8.2	8.3	8.3	27.3	27.3	27.3	8.0	8.0	8.0	96.6	95.3	96.0	3.2	3.1	3.2		5.2	5.2	5.2	
WM2	1238	5.3	Surface	16.6	16.6	16.6	8.2	8.2	8.2	27.3	27.2	27.3	8.2	8.3	8.3	99.3	100.1	99.7	1.6	1.7	1.7		2.6	3.0	2.8	
			Middle																		1.5				2.4	
			Bottom	16.6	16.5	16.6	8.2	8.2	8.2	27.3	27.3	27.3	8.3	8.3	8.3	101.3	101.7	101.5	1.3	1.4	1.4		2.2	1.8	2.0	
WM3	1305	10.0	Surface	16.6	16.6	16.6	8.2	8.3	8.3	27.3	27.3	27.3	8.3	8.3	8.3	100.3	100.5	100.4	3.3	3.3	3.3		5.2	5.4	5.3	
			Middle	16.6	16.6	16.6	8.2	8.2	8.2	27.3	27.3	27.3	8.4	8.4	8.4	101.5	101.8	101.7	2.3	2.4	2.4	2.4	3.8	4.0	3.9	4.0
			Bottom	16.6	16.6	16.6	8.3	8.2	8.3	27.3	27.3	27.3	8.4	8.4	8.4	101.7	101.9	101.8	1.7	1.6	1.7		2.8	2.6	2.7	
WM4	1336	10.2	Surface	16.6	16.6	16.6	8.3	8.2	8.3	27.3	27.4	27.4	8.2	8.3	8.3	99.4	100.3	99.9	2.0	2.1	2.1		3.2	3.4	3.3	
			Middle	16.5	16.5	16.5	8.2	8.2	8.2	27.4	27.4	27.4	8.2	8.2	8.2	98.6	98.9	98.8	1.9	1.8	1.9	2.0	3.2	3.0	3.1	3.2
			Bottom	16.5	16.5	16.5	8.2	8.2	8.2	27.4	27.4	27.4	8.3	8.4	8.4	100.1	101.5	100.8	1.9	2.0	2.0		3.0	3.4	3.2	
CS2	1408	14.9	Surface	16.5	16.4	16.5	8.3	8.3	8.3	27.4	27.5	27.5	9.1	9.0	9.1	109.5	108.4	109.0	1.6	1.7	1.7		2.6	2.8	2.7	
			Middle	16.4	16.4	16.4	8.2	8.3	8.3	27.5	27.5	27.5	8.8	8.8	8.8	106.6	106.9	106.8	2.2	2.4	2.3	2.3	3.6	4.0	3.8	3.7
			Bottom	16.3	16.3	16.3	8.2	8.2	8.2	27.5	27.5	27.5	9.0	9.0	9.0	107.3	108.0	107.7	2.7	2.9	2.8		4.6	4.8	4.7	

Remark or Observation:

Note: \* Average

\*\* Depth Average

**SIL(E) Water Quality Monitoring Data Record Sheet**

Date: 12-Mar-12  
 Tide: Mid-Flood  
 Weather: Cloudy  
 Sea Conditions: Small Wave  
 Upstream Control Station:CS2

Location	Sampling Time	Water Depth (m)	Monitoring Depth	Temperature (°C)			pH			Salinity (ppt)			DO (mg/l)			DO Saturation (%)			Turbidity (NTU)				Suspended Solids (mg/l)							
				1	2	Ave.*	1	2	Ave.*	1	2	Ave.*	1	2	Ave.*	1	2	Ave.*	1	2	Ave.*	D.A.**	1	2	Ave.*	D.A.**				
CS1	1110	12.3	Surface	16.4	16.5	16.5	8.1	8.1	8.1	27.7	27.7	27.7	8.7	8.7	8.7	105.3	104.7	105.0	6.0	6.3	6.2					9.8	10.4	10.1		
			Middle	16.5	16.5	16.5	8.1	8.1	8.1	27.8	27.7	27.8	8.6	8.5	8.6	104.5	103.1	103.8	5.1	5.0	5.1	5.6					8.2	8.2	8.2	9.3
			Bottom	16.5	16.5	16.5	8.1	8.2	8.2	27.8	27.8	27.8	8.7	8.6	8.7	105.0	104.1	104.6	5.6	5.7	5.7					9.4	9.6	9.5		
WM1	1028	14.8	Surface	16.4	16.4	16.4	8.1	8.2	8.2	27.7	27.7	27.7	8.2	8.1	8.2	99.4	98.6	99.0	2.9	2.9	2.9					4.8	4.6	4.7		
			Middle	16.4	16.4	16.4	8.1	8.1	8.1	27.7	27.7	27.7	8.3	8.2	8.3	100.2	99.3	99.8	2.8	2.8	2.8	2.9					4.6	4.6	4.6	4.8
			Bottom	16.5	16.4	16.5	8.1	8.1	8.1	27.8	27.8	27.8	8.1	8.0	8.1	97.8	96.5	97.2	3.1	3.1	3.1					5.2	5.2	5.2		
WM2	1000	5.8	Surface	16.3	16.3	16.3	8.2	8.2	8.2	27.6	27.7	27.7	8.3	8.1	8.2	100.7	98.4	99.6	3.0	3.1	3.1					4.8	5.2	5.0		
			Middle																			3.2							5.3	
			Bottom	16.4	16.4	16.4	8.2	8.2	8.2	27.7	27.7	27.7	8.3	8.3	8.3	100.3	99.3	99.8	3.3	3.5	3.4					5.4	5.8	5.6		
WM3	0928	11.0	Surface	16.3	16.4	16.4	8.1	8.2	8.2	27.6	27.7	27.7	8.3	8.3	8.3	100.2	100.7	100.5	2.9	2.9	2.9					4.6	4.8	4.7		
			Middle	16.4	16.4	16.4	8.2	8.2	8.2	27.7	27.7	27.7	8.2	8.1	8.2	98.9	97.5	98.2	2.8	2.9	2.9	3.4					4.6	4.6	4.6	5.4
			Bottom	16.4	16.5	16.5	8.2	8.1	8.2	27.7	27.7	27.7	8.6	8.5	8.6	103.8	102.7	103.3	4.3	4.3	4.3					6.8	7.2	7.0		
WM4	0857	11.4	Surface	16.4	16.3	16.4	8.2	8.2	8.2	27.7	27.7	27.7	8.4	8.3	8.4	101.1	100.2	100.7	2.9	3.0	3.0					4.2	4.4	4.3		
			Middle	16.4	16.4	16.4	8.2	8.2	8.2	27.7	27.7	27.7	8.6	8.4	8.5	103.6	101.9	102.8	3.7	3.8	3.8	3.7					6.2	6.2	6.2	6.0
			Bottom	16.4	16.4	16.4	8.1	8.1	8.1	27.7	27.8	27.8	8.5	8.5	8.5	103.2	103.8	103.5	4.4	4.5	4.5					7.4	7.6	7.5		
CS2	0830	16.3	Surface	16.4	16.4	16.4	8.1	8.2	8.2	27.7	27.7	27.7	8.8	8.7	8.8	106.6	105.2	105.9	4.2	4.2	4.2					6.6	6.8	6.7		
			Middle	16.4	16.4	16.4	8.1	8.1	8.1	27.8	27.7	27.8	8.8	8.8	8.8	106.2	105.5	105.9	4.9	4.7	4.8	4.5					8.2	7.8	8.0	7.5
			Bottom	16.4	16.5	16.5	8.1	8.1	8.1	27.8	27.8	27.8	8.7	8.5	8.6	105.4	103.9	104.7	4.5	4.6	4.6					7.6	7.8	7.7		

Remark or Observation:

Note: \* Average

\*\* Depth Average

**SIL(E) Water Quality Monitoring Data Record Sheet**

Date: 12-Mar-12  
 Tide: Mid-Ebb  
 Weather: Cloudy  
 Sea Conditions: Small Wave  
 Upstream Control Station:CS1

Location	Sampling Time	Water Depth (m)	Monitoring Depth	Temperature (°C)			pH			Salinity (ppt)			DO (mg/l)			DO Saturation (%)			Turbidity (NTU)				Suspended Solids (mg/l)			
				1	2	Ave.*	1	2	Ave.*	1	2	Ave.*	1	2	Ave.*	1	2	Ave.*	1	2	Ave.*	D.A.**	1	2	Ave.*	D.A.**
CS1	1300	11.9	Surface	16.5	16.5	16.5	8.1	8.2	8.2	27.7	27.8	27.8	8.3	8.3	8.3	99.1	99.8	99.5	5.5	5.5	5.5		8.8	9.0	8.9	
			Middle	16.4	16.5	16.5	8.2	8.2	8.2	27.8	27.8	27.8	8.2	8.3	8.3	98.5	99.4	99.0	5.8	5.9	5.9	5.7	9.6	10.0	9.8	9.4
			Bottom	16.5	16.5	16.5	8.2	8.1	8.2	27.8	27.8	27.8	8.3	8.3	8.3	99.3	98.1	98.7	5.8	5.8	5.8		9.4	9.6	9.5	
WM1	1335	14.3	Surface	16.5	16.5	16.5	8.1	8.1	8.1	27.7	27.7	27.7	7.9	7.8	7.9	94.0	93.2	93.6	3.5	3.7	3.6		5.4	6.2	5.8	
			Middle	16.4	16.5	16.5	8.2	8.2	8.2	27.8	27.7	27.8	7.7	7.9	7.8	93.4	95.8	94.6	3.4	3.4	3.4	3.7	5.6	5.6	5.6	6.1
			Bottom	16.5	16.5	16.5	8.2	8.2	8.2	27.8	27.8	27.8	7.8	7.8	7.8	93.7	93.2	93.5	4.3	4.1	4.2		7.2	6.8	7.0	
WM2	1409	5.3	Surface	16.3	16.4	16.4	8.2	8.1	8.2	27.7	27.6	27.7	8.0	7.9	8.0	96.9	95.8	96.4	3.3	3.4	3.4		5.4	5.6	5.5	
			Middle																		3.5				5.8	
			Bottom	16.3	16.4	16.4	8.2	8.2	8.2	27.6	27.6	27.6	7.9	8.1	8.0	95.8	98.2	97.0	3.7	3.7	3.7		6.2	6.0	6.1	
WM3	1436	11.6	Surface	16.3	16.3	16.3	8.2	8.1	8.2	27.7	27.7	27.7	8.0	8.0	8.0	96.2	96.8	96.5	3.2	3.3	3.3		5.2	5.4	5.3	
			Middle	16.4	16.5	16.5	8.1	8.2	8.2	27.6	27.7	27.7	8.1	8.1	8.1	98.2	98.6	98.4	3.5	3.5	3.5	3.5	5.8	6.2	6.0	5.9
			Bottom	16.5	16.5	16.5	8.2	8.2	8.2	27.7	27.7	27.7	8.3	8.3	8.3	99.6	100.2	99.9	3.8	3.9	3.9		6.2	6.4	6.3	
WM4	1506	10.8	Surface	16.3	16.3	16.3	8.2	8.2	8.2	27.8	27.7	27.8	8.0	8.1	8.1	96.7	97.8	97.3	3.6	3.7	3.7		5.6	6.0	5.8	
			Middle	16.4	16.4	16.4	8.1	8.1	8.1	27.7	27.7	27.7	8.3	8.2	8.3	99.6	98.1	98.9	4.2	4.2	4.2	3.9	6.8	7.0	6.9	6.4
			Bottom	16.4	16.5	16.5	8.2	8.2	8.2	27.8	27.7	27.8	8.1	8.2	8.2	97.0	98.4	97.7	4.0	3.9	4.0		6.4	6.4	6.4	
CS2	1534	15.8	Surface	16.4	16.4	16.4	8.2	8.2	8.2	27.8	27.8	27.8	8.4	8.4	8.4	100.3	100.8	100.6	4.6	4.7	4.7		7.4	7.6	7.5	
			Middle	16.5	16.4	16.5	8.2	8.2	8.2	27.7	27.8	27.8	8.3	8.4	8.4	99.6	100.9	100.3	5.3	5.3	5.3	5.1	8.8	8.6	8.7	8.3
			Bottom	16.5	16.5	16.5	8.2	8.2	8.2	27.8	27.8	27.8	8.2	8.3	8.3	98.2	99.7	99.0	5.4	5.3	5.4		8.8	8.6	8.7	

Remark or Observation:

Note: \* Average

\*\* Depth Average

**SIL(E) Water Quality Monitoring Data Record Sheet**

Date: 14-Mar-12  
 Tide: Mid-Flood  
 Weather: Cloudy  
 Sea Conditions: Small Wave  
 Upstream Control Station:CS2

Location	Sampling Time	Water Depth (m)	Monitoring Depth	Temperature (°C)			pH			Salinity (ppt)			DO (mg/l)			DO Saturation (%)			Turbidity (NTU)				Suspended Solids (mg/l)			
				1	2	Ave.*	1	2	Ave.*	1	2	Ave.*	1	2	Ave.*	1	2	Ave.*	1	2	Ave.*	D.A.**	1	2	Ave.*	D.A.**
CS1	1239	14.2	Surface	16.3	16.3	16.3	8.2	8.2	8.2	27.7	27.6	27.7	8.1	8.1	8.1	97.2	97.6	97.4	3.1	3.2	3.2		5.0	5.2	5.1	
			Middle	16.4	16.3	16.4	8.3	8.2	8.3	27.7	27.7	27.7	8.2	8.2	8.2	98.4	98.7	98.6	2.9	2.4	2.7	3.1	4.6	4.0	4.3	5.1
			Bottom	16.6	16.6	16.6	8.3	8.3	8.3	27.8	27.7	27.8	8.2	8.3	8.3	98.9	98.8	98.9	3.4	3.6	3.5		5.6	6.0	5.8	
WM1	1159	15.0	Surface	16.3	16.3	16.3	8.1	8.1	8.1	27.6	27.6	27.6	8.3	8.3	8.3	100.0	100.4	100.2	1.4	1.8	1.6		2.4	2.8	2.6	
			Middle	16.4	16.3	16.4	8.2	8.2	8.2	27.6	27.7	27.7	8.4	8.4	8.4	101.2	101.6	101.4	1.8	2.0	1.9	2.0	3.0	3.4	3.2	3.3
			Bottom	16.5	16.5	16.5	8.2	8.2	8.2	27.7	27.6	27.7	8.4	8.4	8.4	101.5	101.1	101.3	2.6	2.2	2.4		4.4	3.8	4.1	
WM2	1130	5.8	Surface	16.4	16.4	16.4	8.2	8.2	8.2	27.6	27.6	27.6	8.3	8.3	8.3	100.1	99.9	100.0	1.9	1.8	1.9		3.0	2.8	2.9	
			Middle																		2.1				3.4	
			Bottom	16.5	16.5	16.5	8.3	8.3	8.3	27.6	27.6	27.6	8.2	8.2	8.2	99.2	99.0	99.1	2.3	2.5	2.4		3.8	4.0	3.9	
WM3	1103	10.2	Surface	16.4	16.3	16.4	8.1	8.1	8.1	27.5	27.6	27.6	7.9	7.9	7.9	96.2	96.4	96.3	1.7	1.5	1.6		2.6	2.4	2.5	
			Middle	16.4	16.4	16.4	8.2	8.3	8.3	27.5	27.5	27.5	8.2	8.2	8.2	99.5	99.1	99.3	1.9	1.6	1.8	1.9	3.2	2.8	3.0	3.0
			Bottom	16.5	16.5	16.5	8.2	8.2	8.2	27.6	27.6	27.6	8.4	8.3	8.4	101.8	100.2	101.0	2.1	2.4	2.3		3.4	3.8	3.6	
WM4	1034	10.6	Surface	16.3	16.2	16.3	8.2	8.2	8.2	27.6	27.7	27.7	8.2	8.2	8.2	98.9	99.1	99.0	2.0	1.7	1.9		3.2	2.8	3.0	
			Middle	16.3	16.3	16.3	8.3	8.3	8.3	27.6	27.7	27.7	8.4	8.4	8.4	101.4	101.6	101.5	2.2	2.8	2.5	2.4	3.6	4.2	3.9	3.9
			Bottom	16.3	16.4	16.4	8.3	8.3	8.3	27.5	27.6	27.6	8.3	8.3	8.3	100.2	100.6	100.4	2.8	3.0	2.9		4.6	5.0	4.8	
CS2	1000	15.2	Surface	16.3	16.4	16.4	8.1	8.1	8.1	27.5	27.5	27.5	8.8	8.8	8.8	106.0	106.4	106.2	2.5	2.2	2.4		4.0	3.6	3.8	
			Middle	16.3	16.4	16.4	8.2	8.2	8.2	27.6	27.5	27.6	8.7	8.7	8.7	105.4	105.6	105.5	2.9	3.1	3.0	3.0	4.6	5.0	4.8	4.8
			Bottom	16.3	16.4	16.4	8.2	8.2	8.2	27.6	27.7	27.7	8.6	8.6	8.6	104.0	104.2	104.1	3.4	3.6	3.5		5.6	6.2	5.9	

Remark or Observation:

Note: \* Average

\*\* Depth Average

**SIL(E) Water Quality Monitoring Data Record Sheet**

Date: 14-Mar-12  
 Tide: Mid-Ebb  
 Weather: Cloudy  
 Sea Conditions: Small Wave  
 Upstream Control Station:CS1

Location	Sampling Time	Water Depth (m)	Monitoring Depth	Temperature (°C)			pH			Salinity (ppt)			DO (mg/l)			DO Saturation (%)			Turbidity (NTU)				Suspended Solids (mg/l)			
				1	2	Ave.*	1	2	Ave.*	1	2	Ave.*	1	2	Ave.*	1	2	Ave.*	1	2	Ave.*	D.A.**	1	2	Ave.*	D.A.**
CS1	1415	13.8	Surface	16.3	16.4	16.4	8.2	8.2	8.2	27.4	27.5	27.5	7.9	7.8	7.9	94.8	93.6	94.2	3.4	3.6	3.5	5.4	5.8	5.6		
			Middle	16.4	16.4	16.4	8.2	8.3	8.3	27.5	27.5	27.5	7.8	7.8	7.8	93.6	93.6	93.6	3.5	3.6	3.6	3.6	5.6	5.6	5.6	5.8
			Bottom	16.5	16.4	16.5	8.2	8.3	8.3	27.5	27.6	27.6	7.9	8.0	8.0	94.8	96.0	95.4	3.7	3.8	3.8		6.2	6.2	6.2	
WM1	1445	14.6	Surface	16.4	16.4	16.4	8.2	8.2	8.2	27.5	27.6	27.6	8.0	8.1	8.1	96.0	97.2	96.6	1.7	1.9	1.8	2.6	3.0	2.8		
			Middle	16.5	16.4	16.5	8.2	8.3	8.3	27.6	27.5	27.6	8.1	8.2	8.2	97.2	98.4	97.8	2.2	2.3	2.3	2.3	3.6	3.8	3.7	3.7
			Bottom	16.6	16.5	16.6	8.2	8.3	8.3	27.6	27.6	27.6	8.0	8.2	8.1	96.0	98.4	97.2	2.9	2.7	2.8		4.8	4.4	4.6	
WM2	1515	5.6	Surface	16.3	16.3	16.3	8.2	8.1	8.2	27.4	27.4	27.4	7.9	8.0	8.0	94.8	96.0	95.4	2.2	2.4	2.3		3.6	4.0	3.8	
			Middle																			2.5				4.1
			Bottom	16.4	16.5	16.5	8.2	8.2	8.2	27.5	27.6	27.6	7.8	8.0	7.9	93.6	96.0	94.8	2.6	2.8	2.7		4.2	4.6	4.4	
WM3	1540	9.8	Surface	16.4	16.3	16.4	8.2	8.3	8.3	27.4	27.3	27.4	7.6	7.8	7.7	91.2	93.6	92.4	1.9	2.0	2.0		3.0	3.2	3.1	
			Middle	16.4	16.5	16.5	8.2	8.3	8.3	27.4	27.4	27.4	8.0	8.1	8.1	96.0	97.2	96.6	2.2	2.3	2.3	2.2	3.6	3.8	3.7	3.6
			Bottom	16.5	16.5	16.5	8.2	8.2	8.2	27.5	27.6	27.6	8.1	8.3	8.2	97.2	99.6	98.4	2.4	2.5	2.5		4.0	4.2	4.1	
WM4	1615	10.4	Surface	16.4	16.4	16.4	8.2	8.1	8.2	27.3	27.4	27.4	7.8	7.9	7.9	93.6	94.8	94.2	2.2	2.4	2.3		3.6	4.0	3.8	
			Middle	16.5	16.4	16.5	8.2	8.2	8.2	27.4	27.5	27.5	8.0	7.8	7.9	96.0	93.6	94.8	2.5	2.5	2.5	2.7	4.2	4.2	4.2	4.4
			Bottom	16.6	16.5	16.6	8.2	8.2	8.2	27.6	27.6	27.6	8.2	8.0	8.1	98.4	96.0	97.2	3.1	3.2	3.2		5.2	5.2	5.2	
CS2	1655	14.8	Surface	16.3	16.3	16.3	8.2	8.1	8.2	27.5	27.5	27.5	8.4	8.2	8.3	100.8	98.4	99.6	2.8	3.0	2.9		4.6	5.0	4.8	
			Middle	16.3	16.4	16.4	8.2	8.3	8.3	27.6	27.5	27.6	8.2	8.0	8.1	98.4	96.0	97.2	3.3	3.5	3.4	3.3	5.4	5.8	5.6	5.5
			Bottom	16.5	16.5	16.5	8.2	8.3	8.3	27.6	27.5	27.6	8.0	7.9	8.0	96.0	94.8	95.4	3.6	3.7	3.7		6.0	6.2	6.1	

Remark or Obsevation:

Note: \* Average

\*\* Depth Average

**SIL(E) Water Quality Monitoring Data Record Sheet**

Date: 16-Mar-12  
 Tide: Mid-Flood  
 Weather: Cloudy  
 Sea Conditions: Small Wave  
 Upstream Control Station:CS2

Location	Sampling Time	Water Depth (m)	Monitoring Depth	Temperature (°C)			pH			Salinity (ppt)			DO (mg/l)			DO Saturation (%)			Turbidity (NTU)				Suspended Solids (mg/l)			
				1	2	Ave.*	1	2	Ave.*	1	2	Ave.*	1	2	Ave.*	1	2	Ave.*	1	2	Ave.*	D.A.**	1	2	Ave.*	D.A.**
CS1	1018	11.1	Surface	16.7	16.7	16.7	7.9	7.9	7.9	27.5	27.5	27.5	8.9	8.8	8.9	107.0	105.8	106.4	5.3	5.2	5.3		8.4	8.2	8.3	
			Middle	16.6	16.7	16.7	8.0	8.1	8.1	27.5	27.6	27.6	8.4	8.5	8.5	102.2	102.9	102.6	5.3	5.3	5.3	5.3	8.6	8.4	8.5	8.5
			Bottom	16.6	16.6	16.6	7.9	8.0	8.0	27.5	27.5	27.5	8.3	8.3	8.3	100.2	100.8	100.5	5.3	5.2	5.3		8.8	8.4	8.6	
WM1	0941	14.7	Surface	16.6	16.6	16.6	7.9	7.9	7.9	27.5	27.4	27.5	7.8	7.8	7.8	94.6	95.2	94.9	2.6	2.5	2.6		4.0	4.0	4.0	
			Middle	16.6	16.5	16.6	8.0	8.0	8.0	27.5	27.5	27.5	7.8	7.7	7.8	94.4	93.2	93.8	3.0	3.0	3.0	2.7	5.0	4.8	4.9	4.4
			Bottom	16.5	16.6	16.6	7.9	8.0	8.0	27.5	27.6	27.6	7.9	7.8	7.9	95.6	94.4	95.0	2.6	2.6	2.6		4.4	4.0	4.2	
WM2	0920	5.9	Surface	16.6	16.6	16.6	8.0	8.1	8.1	27.5	27.5	27.5	7.8	7.8	7.8	95.2	94.4	94.8	2.5	2.4	2.5		4.0	4.0	4.0	
			Middle																		3.0				4.9	
			Bottom	16.5	16.6	16.6	7.9	8.0	8.0	27.4	27.5	27.5	7.7	7.8	7.8	92.9	94.1	93.5	3.5	3.5	3.5		5.8	5.6	5.7	
WM3	0853	9.6	Surface	16.5	16.4	16.5	8.0	8.1	8.1	27.5	27.4	27.5	7.9	7.9	7.9	95.4	96.1	95.8	3.0	3.1	3.1		4.8	5.2	5.0	
			Middle	16.5	16.5	16.5	7.9	8.0	8.0	27.5	27.5	27.5	7.9	7.9	7.9	95.2	98.0	96.6	2.2	2.3	2.3	2.9	3.6	3.8	3.7	4.7
			Bottom	16.5	16.5	16.5	8.0	8.0	8.0	27.5	27.5	27.5	7.8	7.7	7.8	94.5	93.4	94.0	3.4	3.4	3.4		5.4	5.4	5.4	
WM4	0826	9.4	Surface	16.5	16.5	16.5	8.1	8.1	8.1	27.5	27.5	27.5	8.0	7.9	8.0	96.6	95.8	96.2	3.4	3.4	3.4		5.6	5.2	5.4	
			Middle	16.5	16.4	16.5	8.0	8.0	8.0	27.6	27.6	27.6	8.0	8.0	8.0	97.1	96.8	97.0	2.9	2.8	2.9	3.0	4.6	4.6	4.6	4.9
			Bottom	16.4	16.4	16.4	8.1	8.0	8.1	27.6	27.5	27.6	8.3	8.2	8.3	100.4	99.2	99.8	2.8	2.8	2.8		4.6	4.8	4.7	
CS2	0800	14.7	Surface	16.5	16.4	16.5	8.0	8.0	8.0	27.6	27.6	27.6	8.5	8.5	8.5	103.0	102.4	102.7	4.3	4.4	4.4		6.6	7.0	6.8	
			Middle	16.4	16.4	16.4	8.1	8.0	8.1	27.5	27.6	27.6	8.6	8.6	8.6	104.0	103.5	103.8	4.9	4.8	4.9	4.6	8.0	7.8	7.9	7.5
			Bottom	16.4	16.3	16.4	8.1	8.1	8.1	27.6	27.5	27.6	8.8	8.7	8.8	105.7	104.8	105.3	4.7	4.7	4.7		7.8	7.6	7.7	

Remark or Observation:

Note: \* Average

\*\* Depth Average

**SIL(E) Water Quality Monitoring Data Record Sheet**

Date: 16-Mar-12  
 Tide: Mid-Ebb  
 Weather: Cloudy  
 Sea Conditions: Small Wave  
 Upstream Control Station:CS1

Location	Sampling Time	Water Depth (m)	Monitoring Depth	Temperature (°C)			pH			Salinity (ppt)			DO (mg/l)			DO Saturation (%)			Turbidity (NTU)				Suspended Solids (mg/l)			
				1	2	Ave.*	1	2	Ave.*	1	2	Ave.*	1	2	Ave.*	1	2	Ave.*	1	2	Ave.*	D.A.**	1	2	Ave.*	D.A.**
CS1	1645	10.8	Surface	16.8	16.7	16.8	8.0	8.0	8.0	27.6	27.6	27.6	8.5	8.5	8.5	102.1	102.8	102.5	5.7	5.9	5.8		9.0	9.4	9.2	
			Middle	16.7	16.7	16.7	8.1	8.0	8.1	27.5	27.6	27.6	8.2	8.0	8.1	98.4	96.7	97.6	5.7	5.7	5.7	5.8	9.2	9.4	9.3	9.4
			Bottom	16.6	16.7	16.7	8.0	8.0	8.0	27.6	27.6	27.6	8.0	8.1	8.1	95.9	97.7	96.8	5.8	5.9	5.9		9.6	9.6	9.6	
WM1	1720	14.2	Surface	16.7	16.7	16.7	8.0	8.0	8.0	27.6	27.5	27.6	7.6	7.4	7.5	91.0	89.3	90.2	3.1	3.1	3.1		5.0	5.2	5.1	
			Middle	16.5	16.5	16.5	8.0	8.0	8.0	27.6	27.6	27.6	7.3	7.3	7.3	88.6	87.7	88.2	3.4	3.6	3.5	3.4	5.4	5.6	5.5	5.5
			Bottom	16.6	16.5	16.6	8.0	8.1	8.1	27.5	27.5	27.5	7.6	7.5	7.6	91.9	90.5	91.2	3.6	3.6	3.6		6.0	5.8	5.9	
WM2	1748	5.5	Surface	16.7	16.7	16.7	8.1	8.0	8.1	27.6	27.5	27.6	7.3	7.1	7.2	88.4	86.9	87.7	2.9	2.8	2.9		4.6	4.6	4.6	
			Middle																			3.0				4.9
			Bottom	16.7	16.6	16.7	8.1	8.1	8.1	27.5	27.6	27.6	7.2	7.3	7.3	87.0	88.1	87.6	3.1	3.1	3.1		5.2	5.0	5.1	
WM3	18.1	9.2	Surface	16.6	16.7	16.7	8.1	8.1	8.1	27.5	27.5	27.5	7.7	7.7	7.7	92.3	92.7	92.5	3.5	3.5	3.5		5.6	5.4	5.5	
			Middle	16.7	16.7	16.7	8.0	8.1	8.1	27.6	27.6	27.6	7.8	7.7	7.8	93.1	92.1	92.6	3.5	3.3	3.4	3.6	5.8	5.4	5.6	5.7
			Bottom	16.6	16.6	16.6	8.1	8.1	8.1	27.6	27.5	27.6	7.5	7.5	7.5	90.6	89.4	90.0	3.7	3.8	3.8		6.0	6.2	6.1	
WM4	1835	9.1	Surface	16.6	16.6	16.6	8.0	8.1	8.1	27.5	27.6	27.6	7.3	7.5	7.4	87.4	89.5	88.5	3.6	3.7	3.7		5.8	6.2	6.0	
			Middle	16.6	16.6	16.6	8.0	8.0	8.0	27.5	27.6	27.6	7.3	7.4	7.4	87.8	88.6	88.2	3.4	3.6	3.5	3.5	5.6	6.0	5.8	5.7
			Bottom	16.6	16.6	16.6	8.0	8.0	8.0	27.6	27.6	27.6	7.8	7.8	7.8	92.9	92.2	92.6	3.4	3.4	3.4		5.4	5.0	5.2	
CS2	1902	14.1	Surface	16.7	16.7	16.7	8.1	8.1	8.1	27.5	27.6	27.6	8.1	8.2	8.2	97.0	98.3	97.7	4.1	4.1	4.1		6.8	6.8	6.8	
			Middle	16.6	16.7	16.7	8.1	8.1	8.1	27.6	27.6	27.6	8.2	8.0	8.1	98.7	96.2	97.5	4.5	4.4	4.5	4.5	7.4	7.2	7.3	7.3
			Bottom	16.6	16.6	16.6	8.1	8.1	8.1	27.6	27.6	27.6	8.2	8.2	8.2	98.5	97.5	98.0	4.8	4.9	4.9		7.8	8.0	7.9	

Remark or Observation:

Note: \* Average

\*\* Depth Average

**SIL(E) Water Quality Monitoring Data Record Sheet**

Date: 19-Mar-12  
 Tide: Mid-Flood  
 Weather: Cloudy  
 Sea Conditions: Small Wave  
 Upstream Control Station:CS2

Location	Sampling Time	Water Depth (m)	Monitoring Depth	Temperature (°C)			pH			Salinity (ppt)			DO (mg/l)			DO Saturation (%)			Turbidity (NTU)				Suspended Solids (mg/l)			
				1	2	Ave.*	1	2	Ave.*	1	2	Ave.*	1	2	Ave.*	1	2	Ave.*	1	2	Ave.*	D.A.**	1	2	Ave.*	D.A.**
CS1	1610	13.8	Surface	17.4	17.3	17.4	8.1	8.0	8.1	27.3	27.3	27.3	8.9	8.8	8.9	107.7	106.5	107.1	3.1	3.0	3.1		5.0	4.8	4.9	
			Middle	17.3	17.3	17.3	8.1	8.0	8.1	27.4	27.3	27.4	8.5	8.6	8.6	102.9	104.1	103.5	4.0	3.8	3.9	3.8	6.4	6.2	6.3	6.3
			Bottom	17.3	17.3	17.3	8.1	8.1	8.1	27.4	27.4	27.4	8.3	8.5	8.4	101.3	102.9	102.1	4.5	4.6	4.6		7.6	7.8	7.7	
WM1	1535	11.6	Surface	17.4	17.4	17.4	8.1	8.1	8.1	27.3	27.3	27.3	8.4	8.3	8.4	101.6	101.3	101.5	2.0	2.1	2.1		3.2	3.4	3.3	
			Middle	17.3	17.4	17.4	8.1	8.0	8.1	27.3	27.4	27.4	8.4	8.3	8.4	101.6	101.3	101.5	2.6	2.4	2.5	2.6	4.2	4.0	4.1	4.2
			Bottom	17.3	17.3	17.3	8.1	8.0	8.1	27.3	27.4	27.4	8.1	8.2	8.2	98.8	100.0	99.4	3.2	3.4	3.3		5.2	5.4	5.3	
WM2	1506	5.8	Surface	17.4	17.4	17.4	8.0	8.1	8.1	27.4	27.4	27.4	8.8	8.7	8.8	106.5	105.3	105.9	2.6	2.7	2.7		4.2	4.4	4.3	
			Middle																		2.9				4.7	
			Bottom	17.3	17.4	17.4	8.0	8.1	8.1	27.5	27.4	27.5	8.6	8.7	8.7	104.1	105.3	104.7	3.0	3.2	3.1		5.0	5.2	5.1	
WM3	1432	9.4	Surface	17.3	17.3	17.3	8.1	8.1	8.1	27.4	27.5	27.5	8.4	8.6	8.5	101.6	104.1	102.9	2.6	2.5	2.6		4.2	4.0	4.1	
			Middle	17.3	17.2	17.3	8.1	8.1	8.1	27.5	27.4	27.5	8.2	8.3	8.3	100.0	101.3	100.7	3.0	3.1	3.1	3.1	4.8	5.2	5.0	5.1
			Bottom	17.3	17.3	17.3	8.1	8.1	8.1	27.5	27.5	27.5	8.1	8.2	8.2	98.8	100.0	99.4	3.7	3.8	3.8		6.0	6.4	6.2	
WM4	1402	10.8	Surface	17.3	17.4	17.4	8.0	8.1	8.1	27.4	27.5	27.5	8.5	8.6	8.6	102.9	104.1	103.5	2.2	2.3	2.3		3.6	3.8	3.7	
			Middle	17.4	17.3	17.4	8.1	8.0	8.1	27.5	27.4	27.5	8.4	8.5	8.5	101.6	102.9	102.3	2.6	2.5	2.6	2.6	4.2	4.2	4.2	4.3
			Bottom	17.2	17.3	17.3	8.1	8.1	8.1	27.4	27.4	27.4	8.3	8.4	8.4	100.4	101.6	101.0	2.9	3.0	3.0		4.8	5.0	4.9	
CS2	1330	14.8	Surface	17.4	17.4	17.4	8.1	8.2	8.2	27.3	27.3	27.3	8.6	8.5	8.6	104.1	102.9	103.5	3.6	3.5	3.6		5.6	5.4	5.5	
			Middle	17.3	17.4	17.4	8.1	8.1	8.1	27.3	27.4	27.4	8.3	8.4	8.4	100.4	101.6	101.0	4.2	4.1	4.2	4.1	6.6	6.6	6.6	6.4
			Bottom	17.3	17.2	17.3	8.1	8.1	8.1	27.4	27.4	27.4	8.3	8.4	8.4	100.4	101.6	101.0	4.5	4.5	4.5		7.2	7.0	7.1	

Remark or Observation:

Note: \* Average

\*\* Depth Average

**SIL(E) Water Quality Monitoring Data Record Sheet**

Date: 19-Mar-12  
 Tide: Mid-Ebb  
 Weather: Cloudy  
 Sea Conditions: Small Wave  
 Upstream Control Station:CS1

Location	Sampling Time	Water Depth (m)	Monitoring Depth	Temperature (°C)			pH			Salinity (ppt)			DO (mg/l)			DO Saturation (%)			Turbidity (NTU)				Suspended Solids (mg/l)							
				1	2	Ave.*	1	2	Ave.*	1	2	Ave.*	1	2	Ave.*	1	2	Ave.*	1	2	Ave.*	D.A.**	1	2	Ave.*	D.A.**				
CS1	0900	13.0	Surface	17.3	17.2	17.3	8.1	8.1	8.1	27.4	27.4	27.4	8.6	8.5	8.6	104.8	104.6	104.7	3.3	3.5	3.4					5.4	5.8	5.6		
			Middle	17.2	17.2	17.2	8.2	8.2	8.2	27.5	27.4	27.5	8.5	8.5	8.5	103.9	103.7	103.8	4.0	4.2	4.1	4.1					6.4	6.8	6.6	6.7
			Bottom	17.1	17.1	17.1	8.2	8.2	8.2	27.5	27.5	27.5	8.4	8.4	8.4	103.3	103.1	103.2	4.8	4.9	4.9					7.8	8.0	7.9		
WM1	0932	10.9	Surface	17.2	17.3	17.3	8.2	8.1	8.2	27.5	27.4	27.5	8.2	8.2	8.2	100.3	100.5	100.4	2.2	2.4	2.3					3.6	4.0	3.8		
			Middle	17.2	17.2	17.2	8.2	8.2	8.2	27.5	27.4	27.5	8.2	8.2	8.2	100.1	100.2	100.2	2.9	3.1	3.0	3.1					4.8	5.2	5.0	5.0
			Bottom	17.1	17.1	17.1	8.1	8.1	8.1	27.5	27.5	27.5	8.1	8.1	8.1	99.6	99.8	99.7	3.8	3.9	3.9					6.2	6.4	6.3		
WM2	0959	5.4	Surface	17.2	17.2	17.2	8.1	8.1	8.1	27.5	27.5	27.5	8.5	8.4	8.5	103.9	103.3	103.6	3.0	3.2	3.1					4.8	5.2	5.0		
			Middle																			3.4							5.2	
			Bottom	17.1	17.0	17.1	8.2	8.2	8.2	27.6	27.5	27.6	8.4	8.4	8.4	103.4	103.6	103.5	3.4	3.8	3.6					5.6	5.2	5.4		
WM3	1023	8.8	Surface	17.2	17.2	17.2	8.1	8.1	8.1	27.3	27.4	27.4	8.1	8.2	8.2	98.8	100.0	99.4	2.8	2.7	2.8					4.6	4.4	4.5		
			Middle	17.2	17.1	17.2	8.2	8.2	8.2	27.5	27.5	27.5	8.0	8.0	8.0	97.6	97.4	97.5	3.2	3.4	3.3	3.4					5.2	5.6	5.4	5.6
			Bottom	17.1	17.0	17.1	8.1	8.2	8.2	27.6	27.5	27.6	8.1	8.0	8.1	98.2	97.8	98.0	4.0	4.2	4.1					6.6	7.0	6.8		
WM4	1049	10.2	Surface	17.3	17.2	17.3	8.2	8.1	8.2	27.4	27.5	27.5	8.3	8.3	8.3	101.3	101.5	101.4	2.0	2.4	2.2					3.2	3.8	3.5		
			Middle	17.2	17.2	17.2	8.2	8.2	8.2	27.4	27.4	27.4	8.2	8.3	8.3	100.2	100.1	100.2	2.9	2.7	2.8	2.7					4.8	4.4	4.6	4.5
			Bottom	17.1	17.2	17.2	8.2	8.2	8.2	27.5	27.4	27.5	8.2	8.2	8.2	100.1	100.5	100.3	3.1	3.3	3.2					5.2	5.4	5.3		
CS2	1132	14.0	Surface	17.2	17.2	17.2	8.2	8.2	8.2	27.5	27.5	27.5	8.2	8.3	8.3	100.4	101.3	100.9	3.8	4.0	3.9					5.8	6.2	6.0		
			Middle	17.1	17.2	17.2	8.1	8.1	8.1	27.3	27.4	27.4	8.2	8.2	8.2	100.0	100.4	100.2	4.2	4.8	4.5	4.4					6.8	7.2	7.0	6.9
			Bottom	17.1	17.0	17.1	8.2	8.1	8.2	27.4	27.4	27.4	8.1	8.1	8.1	98.4	98.5	98.5	4.7	4.9	4.8					7.6	8.0	7.8		

Remark or Observation:

Note: \* Average

\*\* Depth Average

SIL(E) Water Quality Monitoring Data Record Sheet

Date: 21-Mar-12  
 Tide: Mid-Flood  
 Weather: Fine  
 Sea Conditions: Small Wave  
 Upstream Control Station:CS2

Location	Sampling Time	Water Depth (m)	Monitoring Depth	Temperature (°C)			pH			Salinity (ppt)			DO (mg/l)			DO Saturation (%)			Turbidity (NTU)				Suspended Solids (mg/l)			
				1	2	Ave.*	1	2	Ave.*	1	2	Ave.*	1	2	Ave.*	1	2	Ave.*	1	2	Ave.*	D.A.**	1	2	Ave.*	D.A.**
CS1	1732	13.7	Surface	18.1	18.2	18.2	8.1	8.1	8.1	27.8	27.8	27.8	8.2	8.1	8.2	101.9	100.8	101.4	4.7	5.0	4.9		7.4	7.8	7.6	
			Middle	18.1	18.1	18.1	8.0	8.0	8.0	27.7	27.7	27.7	7.9	8.0	8.0	98.0	99.1	98.6	5.8	6.0	5.9	5.9	9.0	9.8	9.4	9.3
			Bottom	18.0	18.0	18.0	8.1	8.0	8.1	27.8	27.7	27.8	8.4	8.5	8.5	104.3	105.8	105.1	6.9	6.7	6.8		11.0	11.0	11.0	
WM1	1656	14.1	Surface	18.1	18.0	18.1	8.2	8.1	8.2	27.8	27.7	27.8	7.6	7.5	7.6	94.3	93.1	93.7	3.3	3.6	3.5		5.4	5.4	5.4	
			Middle	18.0	18.0	18.0	8.1	8.0	8.1	27.8	27.8	27.8	7.4	7.6	7.5	91.7	93.3	92.5	4.3	4.4	4.4	4.3	7.0	7.2	7.1	6.9
			Bottom	18.1	18.0	18.1	8.0	8.1	8.1	27.7	27.7	27.7	7.1	7.2	7.2	88.2	89.4	88.8	5.2	4.9	5.1		8.4	7.8	8.1	
WM2	1625	5.8	Surface	18.1	18.2	18.2	8.1	8.0	8.1	27.7	27.7	27.7	7.6	7.7	7.7	95.0	95.8	95.4	2.7	2.6	2.7		4.4	4.2	4.3	
			Middle																		2.7					4.4
			Bottom	18.3	18.2	18.3	8.1	8.1	8.1	27.8	27.8	27.8	7.8	7.7	7.8	96.5	95.6	96.1	2.8	2.6	2.7		4.6	4.2	4.4	
WM3	1553	11.3	Surface	18.2	18.2	18.2	8.1	8.1	8.1	27.7	27.7	27.7	7.7	7.8	7.8	95.8	96.5	96.2	3.3	3.4	3.4		5.2	5.4	5.3	
			Middle	18.1	18.2	18.2	8.0	8.0	8.0	27.8	27.7	27.8	7.6	7.7	7.7	94.2	95.4	94.8	4.2	4.4	4.3	3.7	7.0	7.2	7.1	6.0
			Bottom	18.1	18.1	18.1	8.0	8.1	8.1	27.8	27.8	27.8	7.8	7.8	7.8	96.5	96.9	96.7	3.5	3.6	3.6		5.6	5.8	5.7	
WM4	1527	11.8	Surface	18.2	18.1	18.2	8.0	8.1	8.1	27.6	27.7	27.7	8.2	8.0	8.1	101.6	99.3	100.5	3.5	3.1	3.3		5.6	5.2	5.4	
			Middle	18.3	18.2	18.3	8.1	8.1	8.1	27.8	27.7	27.8	7.6	7.6	7.6	94.3	94.5	94.4	3.9	3.8	3.9	4.0	6.4	6.2	6.3	6.5
			Bottom	18.1	18.1	18.1	8.1	8.0	8.1	27.7	27.8	27.8	6.9	7.1	7.0	85.9	88.1	87.0	4.6	4.8	4.7		7.6	8.0	7.8	
CS2	1500	15.4	Surface	18.0	18.0	18.0	8.0	8.1	8.1	27.7	27.7	27.7	8.1	8.2	8.2	101.4	102.7	102.1	4.6	4.8	4.7		7.2	7.4	7.3	
			Middle	18.0	18.1	18.1	8.1	8.1	8.1	27.7	27.8	27.8	8.0	8.0	8.0	99.0	99.5	99.3	5.9	5.6	5.8	5.7	9.2	8.8	9.0	8.9
			Bottom	18.1	18.1	18.1	8.0	8.0	8.0	27.7	27.7	27.7	7.7	7.8	7.8	95.8	96.9	96.4	6.8	6.4	6.6		10.6	10.4	10.5	

Remark or Observation:

Note: \* Average

\*\* Depth Average

**SIL(E) Water Quality Monitoring Data Record Sheet**

Date: 21-Mar-12  
 Tide: Mid-Ebb  
 Weather: Cloudy  
 Sea Conditions: Small Wave  
 Upstream Control Station:CS1

Location	Sampling Time	Water Depth (m)	Monitoring Depth	Temperature (°C)			pH			Salinity (ppt)			DO (mg/l)			DO Saturation (%)			Turbidity (NTU)				Suspended Solids (mg/l)			
				1	2	Ave.*	1	2	Ave.*	1	2	Ave.*	1	2	Ave.*	1	2	Ave.*	1	2	Ave.*	D.A.**	1	2	Ave.*	D.A.**
CS1	1030	11.1	Surface	18.0	18.0	18.0	8.1	8.0	8.1	27.5	27.6	27.6	8.5	8.3	8.4	105.6	103.1	104.4	4.7	4.6	4.7		7.4	7.4	7.4	
			Middle	18.0	18.0	18.0	8.1	8.1	8.1	27.6	27.6	27.6	8.3	8.4	8.4	103.1	104.3	103.7	5.9	6.0	6.0	5.7	9.4	9.8	9.6	9.3
			Bottom	18.0	18.0	18.0	8.0	8.1	8.1	27.7	27.7	27.7	8.5	8.5	8.5	105.5	105.3	105.4	6.7	6.5	6.6		11.0	10.6	10.8	
WM1	1102	13.4	Surface	18.0	18.0	18.0	8.0	8.0	8.0	27.7	27.7	27.7	7.7	7.8	7.8	96.4	97.2	96.8	3.2	3.0	3.1		5.2	4.8	5.0	
			Middle	18.1	18.0	18.1	8.1	8.0	8.1	27.7	27.8	27.8	7.7	7.6	7.7	95.7	94.5	95.1	4.1	4.2	4.2	4.0	6.6	6.8	6.7	6.4
			Bottom	18.0	18.0	18.0	8.1	8.1	8.1	27.8	27.8	27.8	7.4	7.5	7.5	92.4	93.1	92.8	4.6	4.8	4.7		7.4	7.8	7.6	
WM2	1130	5.2	Surface	18.0	18.0	18.0	8.2	8.1	8.2	27.7	27.7	27.7	8.0	7.9	8.0	100.2	99.1	99.7	2.5	2.6	2.6		4.2	4.4	4.3	
			Middle																		2.5					4.2
			Bottom	18.0	18.0	18.0	8.1	8.2	8.2	27.7	27.8	27.8	8.0	8.0	8.0	99.5	100.1	99.8	2.4	2.6	2.5		4.0	4.2	4.1	
WM3	1157	9.9	Surface	17.9	18.0	18.0	8.1	8.0	8.1	27.7	27.8	27.8	8.0	7.8	7.9	99.7	96.8	98.3	3.2	3.3	3.3		5.2	5.4	5.3	
			Middle	18.0	18.0	18.0	8.1	8.1	8.1	27.7	27.8	27.8	7.9	8.0	8.0	98.3	99.4	98.9	3.7	3.9	3.8	3.5	6.0	6.4	6.2	5.7
			Bottom	18.0	18.1	18.1	8.0	8.1	8.1	27.8	27.8	27.8	8.1	8.0	8.1	101.3	99.8	100.6	3.5	3.4	3.5		5.6	5.6	5.6	
WM4	1226	10.3	Surface	18.0	18.1	18.1	8.0	8.1	8.1	27.7	27.7	27.7	8.3	8.1	8.2	103.1	100.4	101.8	2.9	3.1	3.0		4.6	5.2	4.9	
			Middle	18.1	18.1	18.1	8.0	8.0	8.0	27.8	27.7	27.8	7.8	7.9	7.9	96.8	98.1	97.5	3.5	3.6	3.6	3.7	5.6	5.6	5.6	5.9
			Bottom	18.1	18.1	18.1	8.1	8.0	8.1	27.8	27.8	27.8	7.5	7.3	7.4	93.1	90.5	91.8	4.4	4.5	4.5		7.2	7.4	7.3	
CS2	1307	13.1	Surface	18.1	18.1	18.1	8.1	8.1	8.1	27.7	27.6	27.7	8.3	8.4	8.4	103.3	104.5	103.9	4.6	4.5	4.6		7.4	7.6	7.5	
			Middle	18.1	18.0	18.1	8.0	8.1	8.1	27.7	27.6	27.7	8.2	8.3	8.3	101.9	103.1	102.5	5.4	5.6	5.5	5.5	8.8	9.0	8.9	9.0
			Bottom	18.1	18.1	18.1	8.0	8.1	8.1	27.7	27.7	27.7	8.0	7.9	8.0	99.3	98.1	98.7	6.4	6.5	6.5		10.4	10.6	10.5	

Remark or Obsevation:

Note: \* Average

\*\* Depth Average

**SIL(E) Water Quality Monitoring Data Record Sheet**

Date: 23-Mar-12  
 Tide: Mid-Flood  
 Weather: Cloudy  
 Sea Conditions: Small Wave  
 Upstream Control Station:CS2

Location	Sampling Time	Water Depth (m)	Monitoring Depth	Temperature (°C)			pH			Salinity (ppt)			DO (mg/l)			DO Saturation (%)			Turbidity (NTU)				Suspended Solids (mg/l)							
				1	2	Ave.*	1	2	Ave.*	1	2	Ave.*	1	2	Ave.*	1	2	Ave.*	1	2	Ave.*	D.A.**	1	2	Ave.*	D.A.**				
CS1	1828	11.4	Surface	18.3	18.3	18.3	8.3	8.3	8.3	27.7	27.8	27.8	7.9	7.9	7.9	98.2	98.8	98.5	3.4	3.5	3.5					5.2	5.4	5.3		
			Middle	18.2	18.3	18.3	8.2	8.3	8.3	27.7	27.7	27.7	7.8	7.9	7.9	97.6	98.6	98.1	3.0	3.0	3.0	3.2					4.8	5.0	4.9	5.0
			Bottom	18.3	18.3	18.3	8.3	8.3	8.3	27.8	27.8	27.8	7.7	7.7	7.7	96.5	96.0	96.3	3.1	3.0	3.1					4.8	4.6	4.7		
WM1	1752	15.1	Surface	18.6	18.5	18.6	8.2	8.2	8.2	27.7	27.8	27.8	8.3	8.4	8.4	102.5	103.4	103.0	3.1	3.1	3.1					4.6	4.6	4.6		
			Middle	18.4	18.4	18.4	8.2	8.2	8.2	27.8	27.8	27.8	8.3	8.3	8.3	101.9	102.6	102.3	3.0	3.1	3.1	3.2					4.6	5.0	4.8	5.0
			Bottom	18.3	18.3	18.3	8.2	8.2	8.2	27.8	27.7	27.8	8.3	8.2	8.3	102.1	101.2	101.7	3.6	3.5	3.6					5.8	5.6	5.7		
WM2	1730	5.8	Surface	18.5	18.5	18.5	8.3	8.3	8.3	27.8	27.8	27.8	8.6	8.5	8.6	106.7	105.9	106.3	2.9	3.0	3.0					4.6	4.6	4.6		
			Middle																			2.9							4.6	
			Bottom	18.4	18.5	18.5	8.2	8.3	8.3	27.8	27.7	27.8	8.5	8.5	8.5	105.7	104.3	105.0	2.9	2.9	2.9					4.6	4.6	4.6		
WM3	1705	10.5	Surface	18.5	18.5	18.5	8.2	8.3	8.3	27.7	27.8	27.8	8.6	8.6	8.6	107.4	107.0	107.2	2.2	2.2	2.2					3.4	3.6	3.5		
			Middle	18.4	18.3	18.4	8.3	8.3	8.3	27.7	27.8	27.8	8.6	8.7	8.7	107.8	108.5	108.2	2.3	2.2	2.3	2.3					3.6	3.6	3.6	3.7
			Bottom	18.3	18.3	18.3	8.3	8.3	8.3	27.8	27.8	27.8	8.2	8.3	8.3	103.3	104.3	103.8	2.6	2.5	2.6					4.0	4.2	4.1		
WM4	1642	10.8	Surface	18.5	18.6	18.6	8.2	8.3	8.3	27.7	27.7	27.7	8.4	8.4	8.4	104.2	103.3	103.8	2.8	2.9	2.9					4.4	4.8	4.6		
			Middle	18.4	18.4	18.4	8.3	8.2	8.3	27.8	27.7	27.8	8.4	8.3	8.4	104.9	103.5	104.2	3.2	3.2	3.2	3.1					5.2	5.2	5.2	5.0
			Bottom	18.3	18.4	18.4	8.2	8.2	8.2	27.8	27.8	27.8	8.3	8.3	8.3	103.1	103.8	103.5	3.2	3.3	3.3					5.2	5.4	5.3		
CS2	1615	14.7	Surface	18.6	18.6	18.6	8.2	8.2	8.2	27.9	27.9	27.9	9.3	9.4	9.4	115.5	116.8	116.2	3.5	3.5	3.5					5.4	5.4	5.4		
			Middle	18.2	18.3	18.3	8.2	8.2	8.2	27.9	27.9	27.9	9.4	9.4	9.4	116.6	116.0	116.3	3.8	3.7	3.8	3.7					6.2	6.2	6.2	6.0
			Bottom	18.3	18.3	18.3	8.3	8.2	8.3	27.9	27.8	27.9	9.0	9.1	9.1	112.7	113.4	113.1	3.9	3.9	3.9					6.6	6.4	6.5		

Remark or Observation:

Note: \* Average

\*\* Depth Average

**SIL(E) Water Quality Monitoring Data Record Sheet**

Date: 23-Mar-12  
 Tide: Mid-Ebb  
 Weather: Cloudy  
 Sea Conditions: Small Wave  
 Upstream Control Station:CS1

Location	Sampling Time	Water Depth (m)	Monitoring Depth	Temperature (°C)			pH			Salinity (ppt)			DO (mg/l)			DO Saturation (%)			Turbidity (NTU)				Suspended Solids (mg/l)			
				1	2	Ave.*	1	2	Ave.*	1	2	Ave.*	1	2	Ave.*	1	2	Ave.*	1	2	Ave.*	D.A.**	1	2	Ave.*	D.A.**
CS1	1130	11.0	Surface	18.1	18.2	18.2	8.2	8.2	8.2	27.7	27.8	27.8	7.5	7.6	7.6	94.2	94.5	94.4	3.2	3.3	3.3	5.0	5.4	5.2		
			Middle	18.1	18.1	18.1	8.2	8.3	8.3	27.7	27.7	27.7	7.7	7.8	7.8	96.1	96.6	96.4	3.2	3.2	3.2	3.3	5.2	5.2	5.2	5.4
			Bottom	18.1	18.1	18.1	8.2	8.3	8.3	27.7	27.7	27.7	7.5	7.5	7.5	94.4	93.7	94.1	3.4	3.6	3.5		5.6	5.8	5.7	
WM1	1205	14.6	Surface	18.4	18.3	18.4	8.3	8.2	8.3	27.8	27.8	27.8	8.0	8.1	8.1	101.1	102.2	101.7	3.6	3.5	3.6	5.6	5.8	5.7		
			Middle	18.3	18.3	18.3	8.2	8.2	8.2	27.8	27.8	27.8	8.1	8.1	8.1	102.1	102.7	102.4	3.4	3.4	3.4	3.6	5.6	5.6	5.6	5.9
			Bottom	18.2	18.2	18.2	8.2	8.3	8.3	27.7	27.7	27.7	8.4	8.4	8.4	104.9	104.6	104.8	3.8	3.9	3.9		6.2	6.4	6.3	
WM2	1232	5.4	Surface	18.3	18.2	18.3	8.2	8.2	8.2	27.8	27.7	27.8	8.6	8.6	8.6	107.8	107.4	107.6	2.5	2.6	2.6		4.0	4.4	4.2	
			Middle																		2.7				4.5	
			Bottom	18.2	18.2	18.2	8.2	8.2	8.2	27.8	27.8	27.8	8.4	8.3	8.4	105.5	104.5	105.0	2.9	2.8	2.9		4.8	4.6	4.7	
WM3	1253	102.0	Surface	18.3	18.3	18.3	8.2	8.2	8.2	27.8	27.7	27.8	8.4	8.3	8.4	105.7	104.2	105.0	2.8	2.7	2.8		4.4	4.4	4.4	
			Middle	18.3	18.4	18.4	8.2	8.3	8.3	27.8	27.8	27.8	8.3	8.2	8.3	103.4	102.8	103.1	2.5	2.5	2.5	2.6	4.2	4.2	4.2	4.4
			Bottom	18.3	18.3	18.3	8.2	8.2	8.2	27.8	27.8	27.8	8.0	8.0	8.0	100.8	100.4	100.6	2.6	2.7	2.7		4.4	4.6	4.5	
WM4	1316	10.4	Surface	18.4	18.3	18.4	8.2	8.3	8.3	27.7	27.8	27.8	8.0	8.1	8.1	100.8	102.1	101.5	3.2	3.3	3.3		4.8	5.4	5.1	
			Middle	18.2	18.3	18.3	8.2	8.2	8.2	27.8	27.8	27.8	8.2	8.2	8.2	103.3	102.7	103.0	3.4	3.5	3.5	3.5	5.6	5.6	5.6	5.6
			Bottom	18.2	18.2	18.2	8.2	8.3	8.3	27.8	27.8	27.8	8.2	8.1	8.2	102.7	101.5	102.1	3.8	3.7	3.8		6.2	6.2	6.2	
CS2	1342	14.4	Surface	18.4	18.4	18.4	8.2	8.3	8.3	27.9	27.8	27.9	9.1	9.1	9.1	114.8	114.2	114.5	5.4	5.3	5.4		8.2	8.2	8.2	
			Middle	18.2	18.1	18.2	8.2	8.3	8.3	27.9	27.9	27.9	9.0	9.0	9.0	112.9	112.2	112.6	5.3	5.3	5.3	5.4	8.8	8.8	8.8	8.7
			Bottom	18.2	18.1	18.2	8.2	8.2	8.2	27.9	27.8	27.9	8.9	8.8	8.9	111.6	110.6	111.1	5.5	5.7	5.6		9.0	9.4	9.2	

Remark or Obsevation:

Note: \* Average

\*\* Depth Average

**SIL(E) Water Quality Monitoring Data Record Sheet**

Date: 26-Mar-12  
 Tide: Mid-Flood  
 Weather: Fine  
 Sea Conditions: Small Wave  
 Upstream Control Station:CS2

Location	Sampling Time	Water Depth (m)	Monitoring Depth	Temperature (°C)			pH			Salinity (ppt)			DO (mg/l)			DO Saturation (%)			Turbidity (NTU)				Suspended Solids (mg/l)			
				1	2	Ave.*	1	2	Ave.*	1	2	Ave.*	1	2	Ave.*	1	2	Ave.*	1	2	Ave.*	D.A.**	1	2	Ave.*	D.A.**
CS1	1036	11.0	Surface	17.8	17.8	17.8	8.1	8.2	8.2	27.7	27.7	27.7	8.1	8.1	8.1	100.2	100.5	100.4	4.0	4.1	4.1		6.2	6.6	6.4	
			Middle	17.7	17.7	17.7	8.1	8.1	8.1	27.7	27.8	27.8	8.2	8.2	8.2	101.7	102.0	101.9	4.5	4.4	4.5	4.4	7.0	6.8	6.9	7.0
			Bottom	17.7	17.7	17.7	8.1	8.1	8.1	27.7	27.8	27.8	8.0	7.9	8.0	99.2	97.9	98.6	4.8	4.7	4.8		7.8	7.6	7.7	
WM1	1003	14.0	Surface	17.7	17.8	17.8	8.1	8.2	8.2	27.8	27.7	27.8	8.4	8.3	8.4	103.9	103.1	103.5	3.2	3.1	3.2		5.2	5.0	5.1	
			Middle	17.7	17.7	17.7	8.1	8.2	8.2	27.8	27.7	27.8	8.4	8.3	8.4	103.9	103.1	103.5	3.2	3.1	3.2	3.2	5.2	5.2	5.2	5.0
			Bottom	17.7	17.7	17.7	8.1	8.2	8.2	27.8	27.8	27.8	8.2	8.2	8.2	101.9	102.2	102.1	3.4	3.3	3.4		4.6	4.6	4.6	
WM2	0933	5.8	Surface	17.7	17.8	17.8	8.2	8.2	8.2	27.8	27.8	27.8	8.3	8.3	8.3	103.1	103.4	103.3	2.8	2.8	2.8		4.2	4.4	4.3	
			Middle																		3.1				4.8	
			Bottom	17.7	17.7	17.7	8.1	8.2	8.2	27.8	27.8	27.8	8.3	8.3	8.3	103.0	103.2	103.1	3.5	3.4	3.5		5.4	5.2	5.3	
WM3	0903	10.0	Surface	17.7	17.8	17.8	8.2	8.3	8.3	27.7	27.7	27.7	8.2	8.1	8.2	101.4	100.7	101.1	2.1	2.2	2.2		3.4	3.6	3.5	
			Middle	17.7	17.7	17.7	8.2	8.2	8.2	27.8	27.7	27.8	8.1	8.2	8.2	101.0	101.3	101.2	3.1	3.0	3.1	2.8	4.8	4.8	4.8	4.4
			Bottom	17.7	17.7	17.7	8.2	8.1	8.2	27.8	27.8	27.8	8.2	8.3	8.3	102.0	102.5	102.3	3.0	3.2	3.1		4.6	5.0	4.8	
WM4	0832	10.2	Surface	17.7	17.7	17.7	8.2	8.1	8.2	27.8	27.7	27.8	8.5	8.5	8.5	105.2	105.7	105.5	2.8	2.9	2.9		4.4	4.6	4.5	
			Middle	17.7	17.8	17.8	8.2	8.3	8.3	27.8	27.8	27.8	8.5	8.6	8.6	105.9	106.2	106.1	3.6	3.5	3.6	3.3	5.6	5.4	5.5	5.1
			Bottom	17.7	17.7	17.7	8.2	8.2	8.2	27.8	27.8	27.8	8.5	8.5	8.5	105.4	105.6	105.5	3.3	3.5	3.4		5.2	5.4	5.3	
CS2	0800	15.2	Surface	17.7	17.6	17.7	8.2	8.2	8.2	27.5	27.6	27.6	8.5	8.5	8.5	105.2	105.5	105.4	2.8	2.9	2.9		4.4	4.6	4.5	
			Middle	17.6	17.6	17.6	8.2	8.1	8.2	27.8	27.8	27.8	8.6	8.6	8.6	106.7	106.5	106.6	3.3	3.4	3.4	3.4	5.2	5.4	5.3	5.3
			Bottom	17.6	17.6	17.6	8.1	8.2	8.2	27.8	27.8	27.8	8.6	8.6	8.6	106.7	107.0	106.9	3.8	3.9	3.9		6.0	6.4	6.2	

Remark or Obsevation:

Note: \* Average

\*\* Depth Average

**SIL(E) Water Quality Monitoring Data Record Sheet**

Date: 26-Mar-12  
 Tide: Mid-Ebb  
 Weather: Fine  
 Sea Conditions: Calm  
 Upstream Control Station:CS1

Location	Sampling Time	Water Depth (m)	Monitoring Depth	Temperature (°C)			pH			Salinity (ppt)			DO (mg/l)			DO Saturation (%)			Turbidity (NTU)				Suspended Solids (mg/l)			
				1	2	Ave.*	1	2	Ave.*	1	2	Ave.*	1	2	Ave.*	1	2	Ave.*	1	2	Ave.*	D.A.**	1	2	Ave.*	D.A.**
CS1	1230	10.8	Surface	17.9	17.8	17.9	8.1	8.1	8.1	27.8	27.8	27.8	8.0	8.0	8.0	99.2	99.4	99.3	3.9	3.9	3.9	6.0	6.0	6.0		
			Middle	17.8	17.7	17.8	8.1	8.2	8.2	27.8	27.7	27.8	8.1	8.1	8.1	100.4	100.7	100.6	4.4	4.6	4.5	4.4	6.8	7.2	7.0	6.9
			Bottom	17.7	17.7	17.7	8.2	8.2	8.2	27.8	27.8	27.8	8.0	8.1	8.1	99.0	99.8	99.4	4.7	4.8	4.8		7.4	7.8	7.6	
WM1	1303	13.6	Surface	17.8	17.8	17.8	8.2	8.2	8.2	27.7	27.7	27.7	8.1	8.1	8.1	100.5	100.8	100.7	3.6	3.5	3.6	5.6	5.4	5.5		
			Middle	17.8	17.7	17.8	8.1	8.2	8.2	27.7	27.8	27.8	8.0	8.1	8.1	99.3	99.9	99.6	3.9	4.0	4.0	3.9	6.2	6.4	6.3	6.2
			Bottom	17.7	17.7	17.7	8.2	8.2	8.2	27.8	27.7	27.8	8.0	8.0	8.0	99.5	99.1	99.3	4.3	4.2	4.3		6.8	6.8	6.8	
WM2	1335	5.4	Surface	17.7	17.7	17.7	8.1	8.1	8.1	27.7	27.8	27.8	8.4	8.3	8.4	104.2	102.9	103.6	3.0	3.1	3.1		4.6	4.8	4.7	
			Middle																		3.4					5.1
			Bottom	17.6	17.7	17.7	8.2	8.1	8.2	27.8	27.8	27.8	8.2	8.3	8.3	102.8	103.2	103.0	3.7	3.6	3.7		5.6	5.4	5.5	
WM3	1400	9.6	Surface	17.8	17.8	17.8	8.2	8.2	8.2	27.7	27.7	27.7	8.0	8.1	8.1	99.3	100.2	99.8	2.4	2.5	2.5	3.8	3.8	3.8		
			Middle	17.7	17.7	17.7	8.1	8.2	8.2	27.7	27.8	27.8	8.0	8.0	8.0	99.4	99.2	99.3	3.0	3.2	3.1	3.1	4.6	5.0	4.8	4.8
			Bottom	17.7	17.7	17.7	8.1	8.1	8.1	27.8	27.9	27.9	8.1	8.1	8.1	100.4	100.8	100.6	3.6	3.7	3.7		5.6	5.8	5.7	
WM4	1431	9.8	Surface	17.8	17.7	17.8	8.1	8.1	8.1	27.7	27.7	27.7	8.4	8.4	8.4	104.2	104.8	104.5	3.2	3.3	3.3	4.8	5.2	5.0		
			Middle	17.8	17.7	17.8	8.2	8.2	8.2	27.8	27.8	27.8	8.3	8.4	8.4	102.9	104.0	103.5	3.8	3.9	3.9	3.7	6.0	6.4	6.2	5.8
			Bottom	17.7	17.7	17.7	8.1	8.2	8.2	27.8	27.7	27.8	8.3	8.3	8.3	102.9	103.3	103.1	4.0	4.1	4.1		6.0	6.2	6.1	
CS2	1509	14.8	Surface	17.8	17.8	17.8	8.1	8.1	8.1	27.7	27.8	27.8	8.3	8.3	8.3	102.9	102.8	102.9	3.5	3.4	3.5	5.4	5.2	5.3		
			Middle	17.7	17.7	17.7	8.2	8.1	8.2	27.7	27.6	27.7	8.4	8.4	8.4	104.2	104.4	104.3	3.9	3.8	3.9	3.8	6.0	6.2	6.1	6.1
			Bottom	17.6	17.7	17.7	8.2	8.2	8.2	27.8	27.8	27.8	8.4	8.3	8.4	104.8	104.0	104.4	4.2	4.2	4.2		7.0	7.0	7.0	

Remark or Observation:

Note: \* Average

\*\* Depth Average

**SIL(E) Water Quality Monitoring Data Record Sheet**

Date: 28-Mar-12  
 Tide: Mid-Flood  
 Weather: Fine  
 Sea Conditions: Calm  
 Upstream Control Station:CS2

Location	Sampling Time	Water Depth (m)	Monitoring Depth	Temperature (°C)			pH			Salinity (ppt)			DO (mg/l)			DO Saturation (%)			Turbidity (NTU)				Suspended Solids (mg/l)			
				1	2	Ave.*	1	2	Ave.*	1	2	Ave.*	1	2	Ave.*	1	2	Ave.*	1	2	Ave.*	D.A.**	1	2	Ave.*	D.A.**
CS1	1027	13.6	Surface	18.2	18.1	18.2	8.1	8.2	8.2	27.6	27.7	27.7	8.5	8.6	8.6	104.9	106.0	105.5	3.0	3.2	3.1		4.8	4.8	4.8	
			Middle	18.1	18.1	18.1	8.2	8.2	8.2	27.7	27.7	27.7	8.6	8.6	8.6	105.6	106.5	106.1	2.8	2.9	2.9	3.1	4.4	4.8	4.6	4.9
			Bottom	18.1	18.1	18.1	8.1	8.1	8.1	27.8	27.8	27.8	8.5	8.4	8.5	104.9	104.3	104.6	3.4	3.2	3.3		5.6	5.2	5.4	
WM1	0955	14.4	Surface	18.1	18.1	18.1	8.2	8.3	8.3	27.8	27.7	27.8	8.3	8.3	8.3	102.4	103.2	102.8	3.4	3.3	3.4		5.2	5.4	5.3	
			Middle	18.1	18.0	18.1	8.2	8.2	8.2	27.7	27.7	27.7	8.4	8.3	8.4	103.9	102.5	103.2	3.3	3.6	3.5	3.5	5.4	6.0	5.7	5.7
			Bottom	18.1	18.2	18.2	8.1	8.2	8.2	27.7	27.8	27.8	8.4	8.5	8.5	104.0	105.2	104.6	3.6	4.0	3.8		5.8	6.4	6.1	
WM2	0927	4.2	Surface	18.1	18.1	18.1	8.2	8.1	8.2	27.7	27.6	27.7	8.3	8.2	8.3	102.4	101.9	102.2	3.5	3.2	3.4		5.4	5.2	5.3	
			Middle																							5.8
			Bottom	18.1	18.0	18.1	8.2	8.2	8.2	27.7	27.7	27.7	8.3	8.3	8.3	102.4	103.0	102.7	3.7	3.9	3.8		6.2	6.4	6.3	
WM3	0902	9.8	Surface	18.1	18.1	18.1	8.2	8.2	8.2	27.7	27.7	27.7	7.9	8.0	8.0	97.5	99.2	98.4	3.0	2.9	3.0		4.6	4.8	4.7	
			Middle	18.1	18.0	18.1	8.1	8.2	8.2	27.7	27.8	27.8	8.2	8.1	8.2	101.2	99.6	100.4	4.1	3.9	4.0	3.4	6.8	6.4	6.6	5.6
			Bottom	18.1	18.1	18.1	8.2	8.2	8.2	27.8	27.8	27.8	8.2	8.3	8.3	101.6	102.6	102.1	3.5	3.2	3.4		5.8	5.2	5.5	
WM4	0836	10.0	Surface	18.0	18.1	18.1	8.1	8.1	8.1	27.8	27.7	27.8	8.8	8.7	8.8	108.4	107.3	107.9	2.5	2.8	2.7		4.0	4.2	4.1	
			Middle	18.1	18.1	18.1	8.1	8.2	8.2	27.9	27.9	27.9	8.6	8.7	8.7	106.1	107.2	106.7	3.5	3.7	3.6	3.1	5.8	6.0	5.9	5.0
			Bottom	18.1	18.0	18.1	8.2	8.2	8.2	27.8	27.9	27.9	8.7	8.7	8.7	107.3	107.9	107.6	3.2	3.0	3.1		5.2	5.0	5.1	
CS2	0810	14.2	Surface	17.9	18.0	18.0	8.1	8.2	8.2	27.8	27.9	27.9	8.3	8.2	8.3	102.1	101.3	101.7	3.2	3.0	3.1		5.0	4.8	4.9	
			Middle	18.0	18.0	18.0	8.2	8.2	8.2	27.9	27.9	27.9	8.6	8.7	8.7	106.1	107.2	106.7	4.2	4.0	4.1	3.9	6.8	6.6	6.7	6.3
			Bottom	18.1	18.0	18.1	8.1	8.2	8.2	27.9	28.0	28.0	9.0	9.1	9.1	111.4	112.2	111.8	4.6	4.3	4.5		7.6	7.0	7.3	

Remark or Observation:

Note: \* Average

\*\* Depth Average

**SIL(E) Water Quality Monitoring Data Record Sheet**

Date: 28-Mar-12  
 Tide: Mid-Ebb  
 Weather: Fine  
 Sea Conditions: Calm  
 Upstream Control Station:CS1

Location	Sampling Time	Water Depth (m)	Monitoring Depth	Temperature (°C)			pH			Salinity (ppt)			DO (mg/l)			DO Saturation (%)			Turbidity (NTU)				Suspended Solids (mg/l)			
				1	2	Ave.*	1	2	Ave.*	1	2	Ave.*	1	2	Ave.*	1	2	Ave.*	1	2	Ave.*	D.A.**	1	2	Ave.*	D.A.**
CS1	1230	13.1	Surface	18.3	18.2	18.3	8.1	8.2	8.2	27.6	27.7	27.7	8.3	8.3	8.3	102.0	102.4	102.2	3.4	3.5	3.5		5.6	5.8	5.7	
			Middle	18.2	18.2	18.2	8.2	8.2	8.2	27.7	27.7	27.7	8.4	8.3	8.4	103.6	102.6	103.1	3.2	3.3	3.3	3.5	5.2	5.4	5.3	5.7
			Bottom	18.2	18.1	18.2	8.2	8.1	8.2	27.7	27.8	27.8	8.3	8.3	8.3	102.7	102.1	102.4	3.6	3.8	3.7		6.0	6.2	6.1	
WM1	1302	14.0	Surface	18.4	18.3	18.4	8.1	8.2	8.2	27.7	27.6	27.7	8.3	8.2	8.3	102.9	101.6	102.3	3.7	3.6	3.7		6.0	5.8	5.9	
			Middle	18.2	18.2	18.2	8.2	8.3	8.3	27.7	27.7	27.7	8.1	8.1	8.1	99.9	100.4	100.2	3.4	3.6	3.5	3.8	5.6	6.0	5.8	6.2
			Bottom	18.1	18.2	18.2	8.3	8.3	8.3	27.7	27.8	27.8	8.1	8.2	8.2	100.3	101.5	100.9	4.2	4.0	4.1		7.0	6.6	6.8	
WM2	1331	3.8	Surface	18.2	18.1	18.2	8.1	8.1	8.1	27.6	27.7	27.7	7.9	8.0	8.0	97.8	99.0	98.4	3.8	3.6	3.7		6.2	6.0	6.1	
			Middle																		3.8				6.2	
			Bottom	18.1	18.0	18.1	8.3	8.2	8.3	27.7	27.7	27.7	8.0	8.0	8.0	98.6	99.0	98.8	4.0	3.8	3.9		6.4	6.0	6.2	
WM3	1358	9.2	Surface	18.3	18.3	18.3	8.1	8.1	8.1	27.7	27.8	27.8	7.6	7.6	7.6	94.3	93.8	94.1	3.2	3.0	3.1		5.2	4.8	5.0	
			Middle	18.3	18.2	18.3	8.1	8.2	8.2	27.7	27.8	27.8	7.7	7.6	7.7	95.3	94.1	94.7	4.2	4.1	4.2	3.6	6.8	6.6	6.7	5.8
			Bottom	18.2	18.2	18.2	8.2	8.2	8.2	27.8	27.8	27.8	7.9	7.8	7.9	97.9	96.7	97.3	3.7	3.5	3.6		5.8	5.8	5.8	
WM4	1427	9.5	Surface	18.4	18.3	18.4	8.1	8.2	8.2	27.8	27.9	27.9	8.3	8.4	8.4	102.9	104.1	103.5	3.0	3.2	3.1		4.8	5.2	5.0	
			Middle	18.3	18.2	18.3	8.2	8.2	8.2	27.8	27.8	27.8	8.2	8.1	8.2	101.6	100.4	101.0	4.0	3.8	3.9	3.5	6.2	6.2	6.2	5.3
			Bottom	18.3	18.2	18.3	8.1	8.2	8.2	27.8	27.8	27.8	8.3	8.3	8.3	102.7	103.2	103.0	3.5	3.7	3.6		4.6	5.0	4.8	
CS2	1509	13.5	Surface	18.5	18.4	18.5	8.1	8.2	8.2	27.9	27.8	27.9	8.2	8.1	8.2	101.2	99.9	100.6	3.5	3.6	3.6		5.4	5.8	5.6	
			Middle	18.4	18.4	18.4	8.2	8.1	8.2	27.9	27.9	27.9	8.5	8.4	8.5	105.2	104.1	104.7	4.3	4.1	4.2	4.0	6.8	6.6	6.7	6.3
			Bottom	18.3	18.4	18.4	8.2	8.2	8.2	27.9	27.9	27.9	8.7	8.8	8.8	107.8	109.1	108.5	4.0	4.2	4.1		6.6	6.8	6.7	

Remark or Obsevation:

Note: \* Average

\*\* Depth Average

**SIL(E) Water Quality Monitoring Data Record Sheet**

Date: 30-Mar-12  
 Tide: Mid-Flood  
 Weather: Cloudy  
 Sea Conditions: Small Wave  
 Upstream Control Station:CS2

Location	Sampling Time	Water Depth (m)	Monitoring Depth	Temperature (°C)			pH			Salinity (ppt)			DO (mg/l)			DO Saturation (%)			Turbidity (NTU)				Suspended Solids (mg/l)							
				1	2	Ave.*	1	2	Ave.*	1	2	Ave.*	1	2	Ave.*	1	2	Ave.*	1	2	Ave.*	D.A.**	1	2	Ave.*	D.A.**				
CS1	1055	14.4	Surface	18.7	18.8	18.8	8.1	8.1	8.1	27.7	27.7	27.7	8.3	8.3	8.3	103.4	102.7	103.1	4.1	4.2	4.2					6.2	6.4	6.3		
			Middle	18.7	18.7	18.7	8.2	8.1	8.2	27.8	27.8	27.8	8.4	8.3	8.4	104.8	103.9	104.4	4.6	4.6	4.6	4.6					7.2	7.2	7.2	7.2
			Bottom	18.5	18.5	18.5	8.2	8.1	8.2	27.8	27.8	27.8	8.3	8.2	8.3	103.1	102.3	102.7	5.1	5.1	5.1					8.2	7.8	8.0		
WM1	1019	13.7	Surface	18.7	18.7	18.7	8.1	8.1	8.1	27.7	27.7	27.7	7.8	7.9	7.9	98.3	99.8	99.1	3.1	3.1	3.1					4.6	5.0	4.8		
			Middle	18.7	18.7	18.7	8.1	8.1	8.1	27.7	27.7	27.7	7.7	7.7	7.7	97.0	97.5	97.3	3.6	3.7	3.7	3.6					5.8	6.0	5.9	5.6
			Bottom	18.7	18.7	18.7	8.1	8.1	8.1	27.7	27.8	27.8	7.6	7.7	7.7	96.2	97.6	96.9	3.9	3.9	3.9					6.0	6.4	6.2		
WM2	0958	5.9	Surface	18.9	18.8	18.9	8.2	8.2	8.2	27.4	27.3	27.4	7.6	7.6	7.6	96.7	95.4	96.1	3.2	3.2	3.2					5.0	4.8	4.9		
			Middle																			3.1							4.8	
			Bottom	18.8	18.8	18.8	8.2	8.1	8.2	27.4	27.4	27.4	7.8	7.8	7.8	98.1	98.8	98.5	3.0	2.9	3.0					4.8	4.4	4.6		
WM3	0935	10.1	Surface	18.8	18.8	18.8	8.1	8.2	8.2	27.7	27.7	27.7	8.1	8.0	8.1	102.3	101.7	102.0	3.1	3.1	3.1					4.8	4.8	4.8		
			Middle	18.7	18.7	18.7	8.1	8.1	8.1	27.8	27.7	27.8	8.5	8.4	8.5	107.2	106.1	106.7	3.6	3.7	3.7	3.6					5.6	6.0	5.8	5.6
			Bottom	18.5	18.5	18.5	8.1	8.1	8.1	27.8	27.8	27.8	8.5	8.4	8.5	107.3	106.6	107.0	4.0	3.9	4.0					6.0	6.4	6.2		
WM4	0912	10.8	Surface	18.9	18.8	18.9	8.1	8.2	8.2	27.7	27.7	27.7	8.4	8.5	8.5	106.2	107.3	106.8	2.9	2.8	2.9					4.6	4.6	4.6		
			Middle	18.7	18.7	18.7	8.2	8.2	8.2	27.8	27.8	27.8	8.6	8.7	8.7	109.5	110.2	109.9	3.4	3.4	3.4	3.2					5.6	5.2	5.4	5.0
			Bottom	18.5	18.5	18.5	8.2	8.2	8.2	27.9	27.8	27.9	8.6	8.6	8.6	109.0	109.7	109.4	3.2	3.4	3.3					5.0	5.2	5.1		
CS2	0845	15.2	Surface	18.7	18.7	18.7	8.1	8.1	8.1	27.6	27.6	27.6	9.0	8.9	9.0	113.2	112.6	112.9	3.2	3.3	3.3					5.0	5.4	5.2		
			Middle	18.6	18.7	18.7	8.1	8.2	8.2	27.7	27.8	27.8	9.1	9.1	9.1	114.0	114.6	114.3	3.6	3.6	3.6	3.6					5.6	5.4	5.5	5.6
			Bottom	18.5	18.5	18.5	8.1	8.1	8.1	27.8	27.8	27.8	9.1	9.0	9.1	114.9	113.8	114.4	4.0	4.0	4.0					6.2	6.2	6.2		

Remark or Obsevation:

Note: \* Average

\*\* Depth Average

**SIL(E) Water Quality Monitoring Data Record Sheet**

Date: 30-Mar-12  
 Tide: Mid-Ebb  
 Weather: Cloudy  
 Sea Conditions: Small Wave  
 Upstream Control Station:CS1

Location	Sampling Time	Water Depth (m)	Monitoring Depth	Temperature (°C)			pH			Salinity (ppt)			DO (mg/l)			DO Saturation (%)			Turbidity (NTU)				Suspended Solids (mg/l)			
				1	2	Ave.*	1	2	Ave.*	1	2	Ave.*	1	2	Ave.*	1	2	Ave.*	1	2	Ave.*	D.A.**	1	2	Ave.*	D.A.**
CS1	1415	13.7	Surface	18.8	18.8	18.8	8.2	8.2	8.2	27.7	27.7	27.7	8.7	8.5	8.6	109.1	106.6	107.9	4.0	4.2	4.1		6.0	6.4	6.2	
			Middle	18.8	18.8	18.8	8.1	8.2	8.2	27.8	27.7	27.8	8.1	8.0	8.1	102.1	100.9	101.5	4.9	5.1	5.0	4.9	7.4	7.2	7.3	7.3
			Bottom	18.7	18.8	18.8	8.1	8.2	8.2	27.8	27.8	27.8	8.2	8.1	8.2	103.5	102.2	102.9	5.4	5.5	5.5		8.2	8.4	8.3	
WM1	1449	12.8	Surface	18.8	18.9	18.9	8.1	8.1	8.1	27.6	27.7	27.7	7.7	7.5	7.6	96.7	94.1	95.4	3.4	3.5	3.5		5.2	5.8	5.5	
			Middle	18.8	18.8	18.8	8.2	8.1	8.2	27.7	27.6	27.7	8.0	7.9	8.0	100.4	99.2	99.8	3.8	3.7	3.8	3.8	5.8	6.4	6.1	6.1
			Bottom	18.8	18.7	18.8	8.1	8.1	8.1	27.8	27.8	27.8	7.8	7.9	7.9	97.9	99.1	98.5	4.2	4.3	4.3		6.6	6.8	6.7	
WM2	1518	5.3	Surface	18.7	18.8	18.8	8.1	8.2	8.2	27.3	27.3	27.3	7.3	7.2	7.3	91.5	90.1	90.8	3.7	3.8	3.8		5.8	6.0	5.9	
			Middle																		3.6				5.5	
			Bottom	18.8	18.8	18.8	8.2	8.1	8.2	27.4	27.3	27.4	7.5	7.6	7.6	93.9	95.2	94.6	3.4	3.3	3.4		5.2	5.0	5.1	
WM3	1544	10.6	Surface	18.9	18.9	18.9	8.2	8.1	8.2	27.8	27.7	27.8	7.9	8.1	8.0	99.3	101.8	100.6	3.6	3.5	3.6		5.6	5.4	5.5	
			Middle	18.9	18.8	18.9	8.2	8.2	8.2	27.8	27.8	27.8	8.3	8.5	8.4	104.4	106.9	105.7	3.9	4.0	4.0	4.0	6.0	6.2	6.1	6.1
			Bottom	18.7	18.7	18.7	8.1	8.1	8.1	27.8	27.9	27.9	8.0	8.1	8.1	100.5	101.8	101.2	4.3	4.4	4.4		6.6	6.8	6.7	
WM4	1616	11.3	Surface	18.9	19.0	19.0	8.2	8.1	8.2	27.6	27.7	27.7	8.1	8.2	8.2	102.0	103.2	102.6	3.1	3.3	3.2		4.8	5.2	5.0	
			Middle	18.9	18.9	18.9	8.1	8.1	8.1	27.8	27.7	27.8	8.5	8.6	8.6	106.9	108.2	107.6	3.7	3.8	3.8	3.5	5.8	5.8	5.8	5.5
			Bottom	18.8	18.7	18.8	8.2	8.1	8.2	27.8	27.8	27.8	8.0	8.0	8.0	100.7	101.1	100.9	3.6	3.7	3.7		5.4	5.8	5.6	
CS2	1649	14.8	Surface	18.8	18.9	18.9	8.2	8.2	8.2	27.7	27.7	27.7	9.1	9.0	9.1	114.6	113.2	113.9	3.5	3.7	3.6		5.4	5.8	5.6	
			Middle	18.8	18.8	18.8	8.1	8.2	8.2	27.8	27.9	27.9	8.6	8.7	8.7	108.2	109.5	108.9	4.0	4.1	4.1	4.1	6.2	6.6	6.4	6.4
			Bottom	18.7	18.6	18.7	8.1	8.1	8.1	27.8	27.9	27.9	8.2	8.4	8.3	103.2	105.7	104.5	4.6	4.7	4.7		7.0	7.2	7.1	

Remark or Observation:

Note: \* Average

\*\* Depth Average

## APPENDIX E

### Review of Exceedance in Water Quality Monitoring

Sampling Date	Tidal Mode	Parameter			Remarks
		DO	Turbidity	SS	
2 Mar 2012	Mid-Ebb & Mid-Flood	AL, LL	-	-	<p>Exceedances of Action/ Limit Levels were recorded at middle &amp; bottom levels at WM1, WM3 &amp; WM4 for mid-flood tide, surface level at WM1 and middle &amp; bottom levels at WM1, WM3 &amp; WM4 for mid-ebb tide.</p> <p>The exceedances have been investigated and were considered not related to the project works. DO exceedances recorded only at WM1, WM3 &amp; WM4 while they were situated far away from the work sites. Also, the silt curtain has been inspected and was functioned properly. As such, the natural fluctuation of the marine water quality has been considered attributed to the low DO levels.</p>

*Note: AL – Action Level ; LL – Limit Level*