

Plan View of CCPP

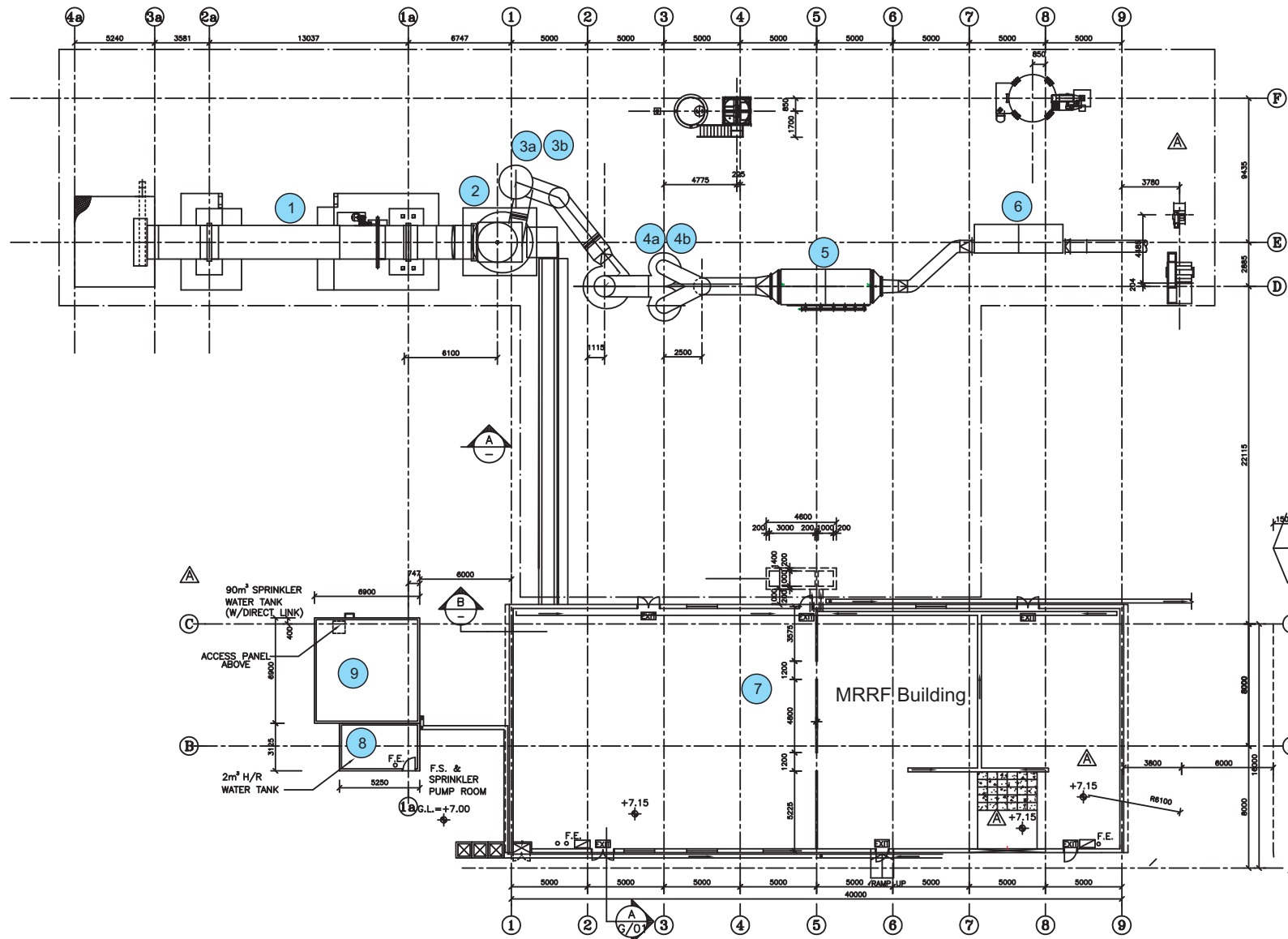

Elevation Plan of CCPP

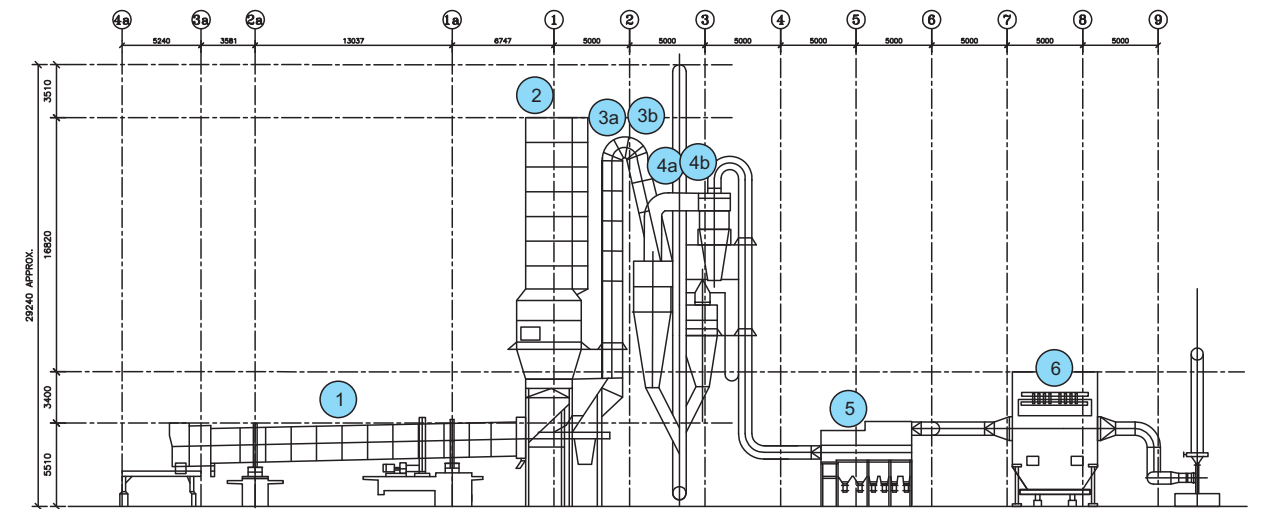

| Major equipment and building details | |
|--------------------------------------|-----------------------------------|
| Equipment | Dimension |
| 1 Rotary Kiln | Dia 2.2 x 21.6m long |
| 2 Secondary Combustion Chamber | Dia 2.6 x 16.8m long |
| 3a Precalciner 1 | Dia 2.2x11m long |
| 3b Precalciner 2 | Dia 1.3x10m long |
| 4a Cyclone 1 | cyclone body Dia 2.4x 7.9m height |
| 4b Cyclone 2 | cyclone body Dia 1.7x 5.6m height |
| 5 Heat exchanger | 2m x 7.6m x 4.8m height |
| 6 Dust collector | 3.4m x 7.6m x 10m height |
| 7 MRRF building | 40m x 16m x 6.8m |
| 8 FS water tank | 7m x 7m x 3.7m height |
| 9 FS water pump house | 5.3m x 3.2m x 2.6m height |

Figure 2.2a

Structure to be Demolished (1)

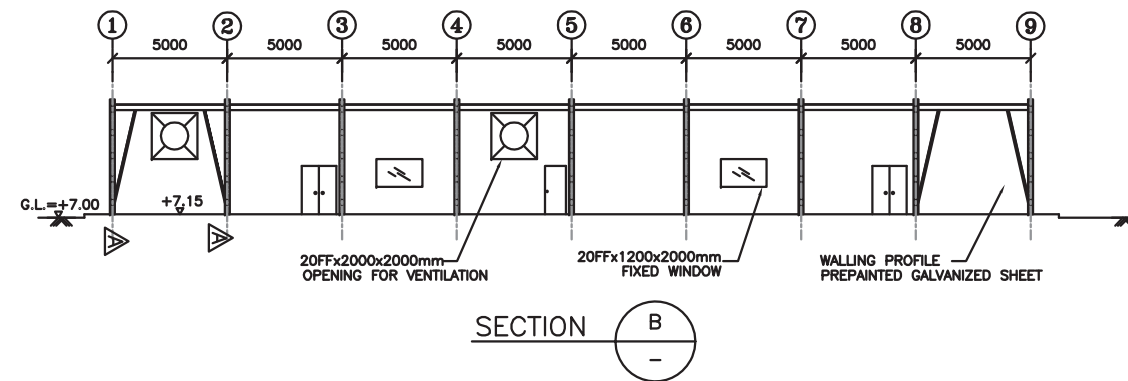
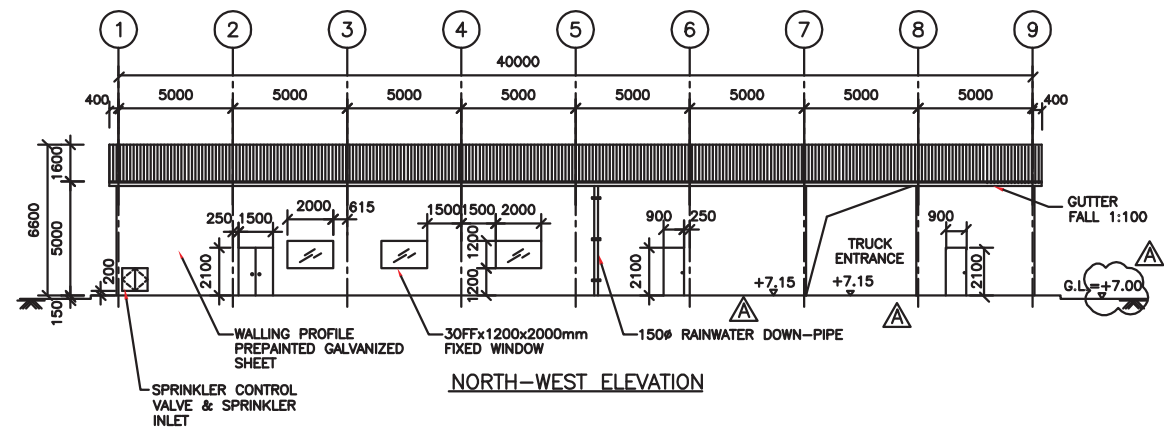
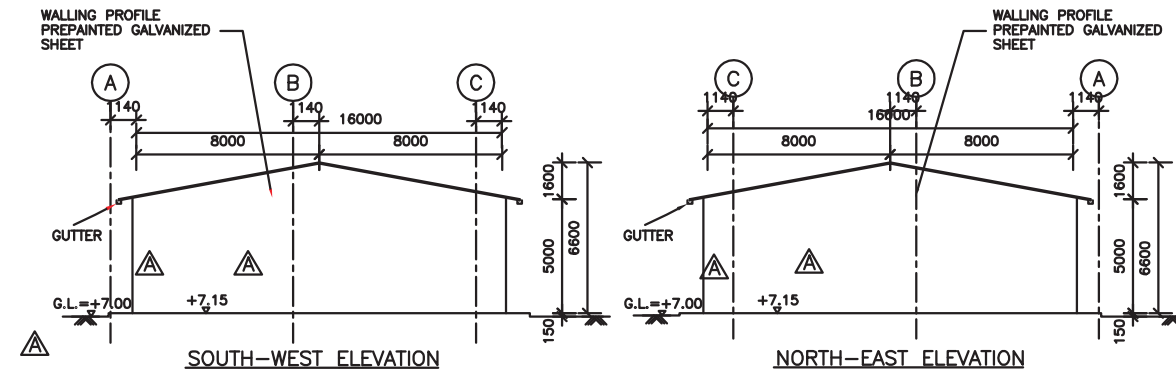
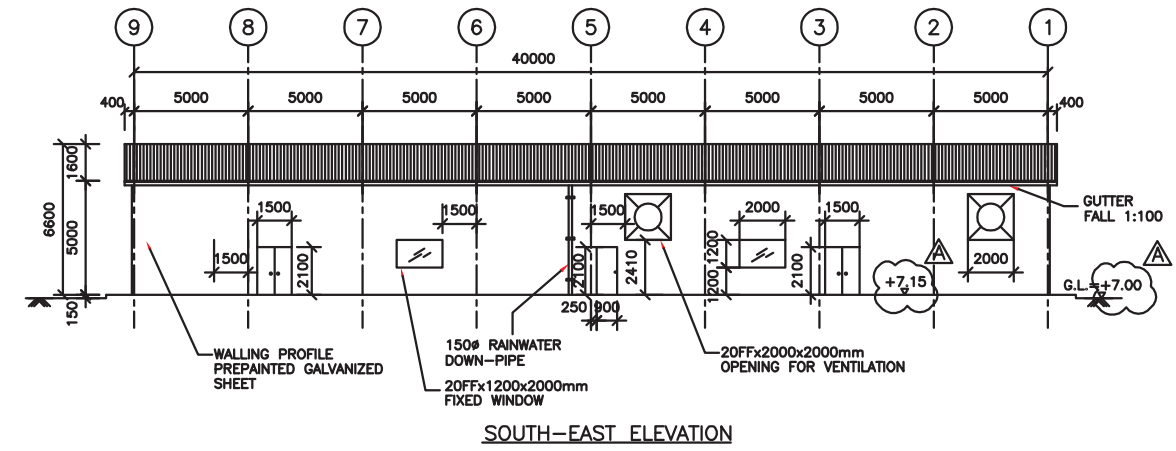
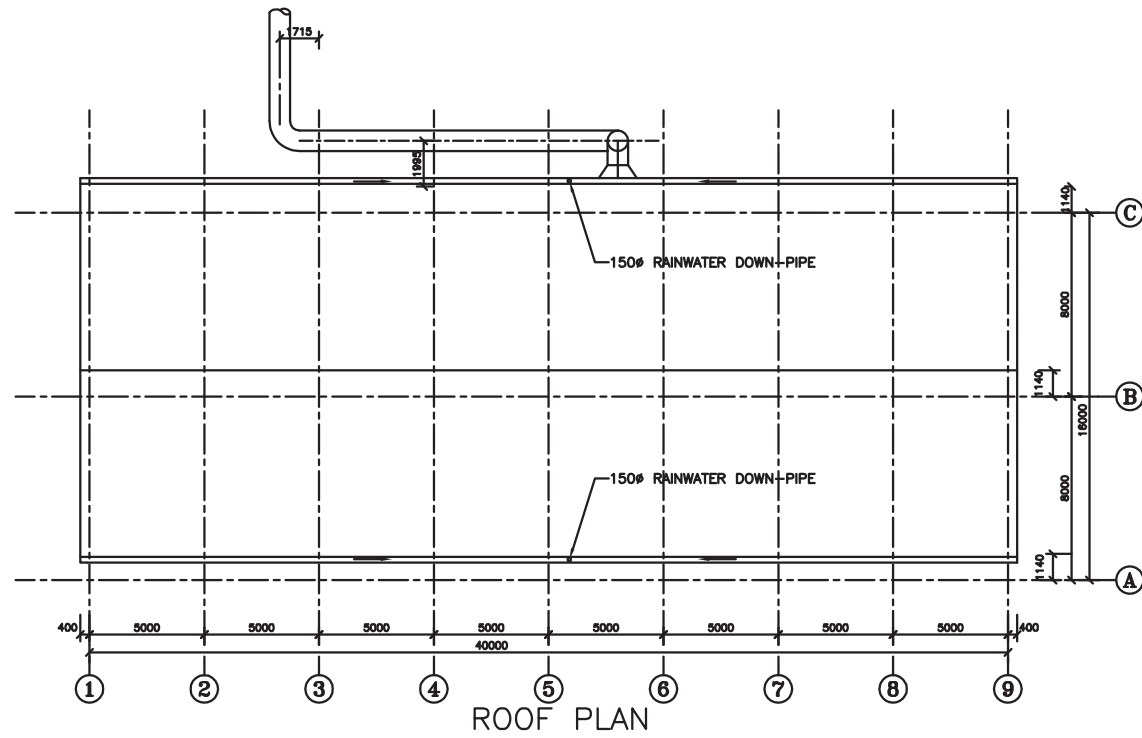

Figure 2.2b

Structure to be Demolished (2)
(Workshop and Reception Hall)

FILE: 0071019k2
DATE: 04/03/2009

Environmental
Resources
Management



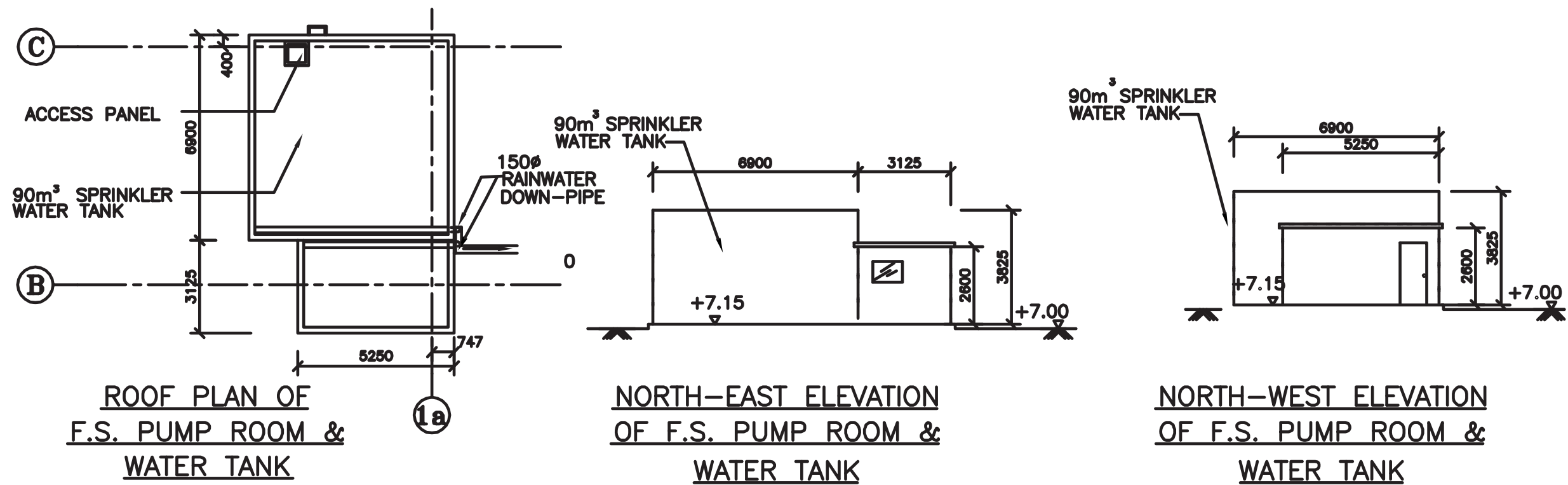

Figure 2.2c

Structure to be Demolished (3)
(Fire Services Water Tank and Pump Room)