

APPENDIX 5F-2

**Vehicle Emission
Factors for 2031
(including composite
vehicle emission factor
for each road link)**

Calculation of NOX Emission Factor (gm/mile/vehicle) for each hours for BCF (HK)

Hour	MC-1	MC-3	MC-4	MC-5	MC-6	MC-7	MC-8	MC-10	MC-11	Taxi-3	Taxi-4	Taxi-5	Taxi-6	Taxi-7	Taxi-8	Taxi-10	
0:00	1:00	0.111	0.222	0.226	0.109	1.300	2.384	3.097	1.877	1.043	0.291	#DIV/0!	#DIV/0!	1.291	2.362	3.099	1.427
1:00	2:00	0.111	0.222	0.226	0.113	1.299	2.382	3.097	1.875	1.045	0.291	#DIV/0!	#DIV/0!	1.290	2.360	3.095	1.357
2:00	3:00	0.111	0.239	0.225	0.104	1.302	2.388	3.101	1.876	1.049	0.292	#DIV/0!	#DIV/0!	1.292	2.364	3.098	#DIV/0!
3:00	4:00	0.112	0.315	0.227	0.110	1.304	2.386	3.103	1.884	1.055	0.293	#DIV/0!	#DIV/0!	1.294	2.364	3.099	#DIV/0!
4:00	5:00	0.112	0.225	0.226	0.109	1.304	2.394	3.108	1.882	1.058	0.294	#DIV/0!	#DIV/0!	1.297	2.373	3.105	#DIV/0!
5:00	6:00	0.113	0.239	0.227	0.105	1.307	2.395	3.113	1.886	1.060	0.295	#DIV/0!	#DIV/0!	1.298	2.375	3.113	1.437
6:00	7:00	0.113	0.233	0.227	0.109	1.308	2.398	3.115	1.888	1.062	0.295	#DIV/0!	#DIV/0!	1.299	2.375	3.115	1.450
7:00	8:00	0.115	0.232	0.229	0.108	1.318	2.417	3.140	1.896	1.050	0.298	0.229	0.198	1.313	2.402	3.150	1.455
8:00	9:00	0.115	0.232	0.229	0.107	1.320	2.421	3.145	1.899	1.048	0.299	0.230	0.198	1.315	2.405	3.155	1.451
9:00	10:00	0.115	0.231	0.229	0.109	1.321	2.422	3.147	1.900	1.045	0.300	0.230	0.198	1.316	2.406	3.157	1.464
10:00	11:00	0.115	0.231	0.229	0.107	1.320	2.420	3.144	1.899	1.039	0.300	0.229	0.197	1.315	2.405	3.154	1.464
11:00	12:00	0.116	0.232	0.229	0.109	1.320	2.420	3.144	1.898	1.035	0.300	0.230	0.199	1.315	2.404	3.153	1.455
12:00	13:00	0.116	0.230	0.229	0.109	1.320	2.420	3.144	1.899	1.034	0.301	0.230	0.197	1.315	2.404	3.154	1.446
13:00	14:00	0.116	0.230	0.229	0.108	1.318	2.417	3.140	1.896	1.029	0.301	0.229	0.198	1.313	2.401	3.149	1.455
14:00	15:00	0.115	0.230	0.228	0.105	1.316	2.412	3.134	1.893	1.026	0.300	0.229	0.195	1.311	2.397	3.144	1.446
15:00	16:00	0.115	0.231	0.228	0.109	1.316	2.413	3.134	1.893	1.026	0.299	0.229	0.197	1.311	2.397	3.144	1.441
16:00	17:00	0.115	0.232	0.228	0.107	1.316	2.413	3.134	1.892	1.028	0.298	0.229	0.196	1.311	2.397	3.144	1.441
17:00	18:00	0.114	0.229	0.228	0.108	1.314	2.410	3.131	1.891	1.029	0.296	0.229	0.197	1.309	2.394	3.140	1.455
18:00	19:00	0.114	0.228	0.228	0.106	1.313	2.407	3.127	1.888	1.030	0.295	0.229	0.196	1.308	2.391	3.136	1.451
19:00	20:00	0.113	0.231	0.228	0.106	1.313	2.407	3.127	1.888	1.031	0.295	#DIV/0!	#DIV/0!	1.308	2.392	3.136	1.441
20:00	21:00	0.114	0.228	0.228	0.107	1.313	2.409	3.129	1.890	1.034	0.295	#DIV/0!	#DIV/0!	1.309	2.392	3.138	1.441
21:00	22:00	0.113	0.231	0.228	0.108	1.312	2.406	3.126	1.888	1.033	0.295	#DIV/0!	#DIV/0!	1.307	2.390	3.136	1.441
22:00	23:00	0.113	0.228	0.228	0.108	1.312	2.405	3.125	1.887	1.034	0.294	#DIV/0!	#DIV/0!	1.307	2.389	3.134	1.441
23:00	0:00	0.111	0.226	0.226	0.108	1.301	2.385	3.099	1.879	1.042	0.291	#DIV/0!	#DIV/0!	1.292	2.363	3.099	1.450
	Day	0.114	0.230	0.228	0.108	1.315	2.411	3.132	1.892	1.037	0.297	0.229	0.197	1.309	2.394	3.140	1.451

Note:

Vehicle classes

- MC-1 PC+LGV-petrol
- MC-3 PC+LGV<2.6-diesel
- MC-4 LGV2.6-3.5t-diesel
- MC-5 PLB (LPG/Diesel)
- MC-6 LGV>3.5t-diesel
- MC-7 HGV<15t-diesel
- MC-8 HGV>15t-diesel
- MC-10 Fran DD bus - diesel
- MC-11 Motorcycle -petrol
- Taxi-3 Taxi
- Taxi-4 PrLB<3.5t-diesel
- Taxi-5 PrLB>3.5t (LPG/Diesel)
- Taxi-6 Non-fran bus<6.4t-diesel
- Taxi-7 Non-fran bus<6.4-15t-diesel
- Taxi-8 Non-fran bus>15t-diesel
- Taxi-10 Fran SD bus - diesel

#DIV/0! means zero VMT

Calculation of RSP Emission Factor (gm/mile/vehicle) for each hours for BCF (HK)

Hour	MC-1	MC-3	MC-4	MC-5	MC-6	MC-7	MC-8	MC-10	MC-11	Taxi-3	Taxi-4	Taxi-5	Taxi-6	Taxi-7	Taxi-8	Taxi-10	
0:00	1:00	0.005	0.074	0.064	0.078	0.062	0.081	0.073	0.043	0.039	0.028	#DIV/0!	#DIV/0!	0.045	0.071	0.067	0.075
1:00	2:00	0.005	0.083	0.063	0.072	0.062	0.080	0.073	0.041	0.038	0.027	#DIV/0!	#DIV/0!	0.046	0.070	0.066	0.000
2:00	3:00	0.005	0.090	0.063	0.078	0.061	0.082	0.073	0.048	0.038	0.028	#DIV/0!	#DIV/0!	0.046	0.071	0.068	#DIV/0!
3:00	4:00	0.005	0.000	0.063	0.074	0.061	0.079	0.072	0.040	0.039	0.028	#DIV/0!	#DIV/0!	0.044	0.069	0.060	#DIV/0!
4:00	5:00	0.005	0.056	0.063	0.078	0.060	0.083	0.072	0.045	0.037	0.027	#DIV/0!	#DIV/0!	0.047	0.073	0.062	#DIV/0!
5:00	6:00	0.005	0.072	0.063	0.072	0.062	0.081	0.073	0.044	0.039	0.027	#DIV/0!	#DIV/0!	0.045	0.071	0.066	0.080
6:00	7:00	0.005	0.081	0.064	0.076	0.062	0.081	0.073	0.044	0.039	0.027	#DIV/0!	#DIV/0!	0.045	0.070	0.066	0.058
7:00	8:00	0.005	0.082	0.066	0.075	0.064	0.084	0.076	0.045	0.039	0.028	0.113	0.133	0.047	0.074	0.068	0.040
8:00	9:00	0.005	0.085	0.066	0.074	0.064	0.084	0.075	0.045	0.039	0.028	0.113	0.132	0.048	0.074	0.069	0.047
9:00	10:00	0.005	0.085	0.066	0.074	0.064	0.084	0.075	0.045	0.039	0.028	0.113	0.132	0.048	0.074	0.069	0.047
10:00	11:00	0.005	0.085	0.066	0.073	0.064	0.084	0.076	0.045	0.039	0.028	0.113	0.132	0.048	0.074	0.068	0.046
11:00	12:00	0.005	0.082	0.066	0.075	0.064	0.084	0.076	0.044	0.039	0.028	0.113	0.132	0.047	0.074	0.069	0.046
12:00	13:00	0.005	0.085	0.066	0.075	0.064	0.084	0.076	0.044	0.039	0.028	0.113	0.132	0.047	0.074	0.069	0.040
13:00	14:00	0.005	0.085	0.066	0.075	0.064	0.083	0.075	0.045	0.039	0.028	0.113	0.132	0.047	0.074	0.068	0.055
14:00	15:00	0.005	0.085	0.066	0.073	0.064	0.083	0.075	0.045	0.039	0.028	0.113	0.133	0.047	0.074	0.069	0.040
15:00	16:00	0.005	0.085	0.066	0.074	0.064	0.084	0.076	0.045	0.039	0.028	0.113	0.131	0.047	0.073	0.069	0.055
16:00	17:00	0.005	0.082	0.066	0.075	0.064	0.084	0.076	0.045	0.039	0.028	0.113	0.131	0.048	0.074	0.069	0.046
17:00	18:00	0.005	0.085	0.066	0.075	0.064	0.084	0.076	0.045	0.039	0.028	0.113	0.132	0.048	0.074	0.068	0.046
18:00	19:00	0.005	0.085	0.066	0.074	0.064	0.084	0.076	0.045	0.039	0.028	0.113	0.131	0.047	0.074	0.069	0.040
19:00	20:00	0.005	0.085	0.066	0.073	0.064	0.084	0.075	0.045	0.039	0.028	0.113	0.132	0.047	0.074	0.069	0.047
20:00	21:00	0.005	0.086	0.066	0.075	0.064	0.083	0.075	0.045	0.039	0.028	#DIV/0!	#DIV/0!	0.047	0.074	0.068	0.046
21:00	22:00	0.005	0.085	0.066	0.075	0.064	0.084	0.076	0.045	0.039	0.028	#DIV/0!	#DIV/0!	0.047	0.074	0.069	0.046
22:00	23:00	0.005	0.086	0.066	0.075	0.064	0.083	0.075	0.045	0.039	0.028	#DIV/0!	#DIV/0!	0.047	0.074	0.069	0.046
23:00	0:00	0.005	0.082	0.063	0.074	0.062	0.081	0.073	0.045	0.039	0.028	#DIV/0!	#DIV/0!	0.047	0.074	0.069	0.046
	Day	0.005	0.084	0.065	0.075	0.064	0.083	0.075	0.045	0.039	0.027	#DIV/0!	#DIV/0!	0.045	0.070	0.065	0.058

Note:

Vehicle classes

- MC-1 PC+LGV-petrol
- MC-3 PC+LGV<2.6-diesel
- MC-4 LGV2.6-3.5t-diesel
- MC-5 PLB (LPG/Diesel)
- MC-6 LGV>3.5t-diesel
- MC-7 HGV<15t-diesel
- MC-8 HGV>15t-diesel
- MC-10 Fran DD bus - diesel
- MC-11 Motorcycle -petrol
- Taxi-3 Taxi
- Taxi-4 PrLB<3.5t-diesel
- Taxi-5 PrLB>3.5t (LPG/Diesel)
- Taxi-6 Non-fran bus<6.4t-diesel
- Taxi-7 Non-fran bus<6.4-15t-diesel
- Taxi-8 Non-fran bus>15t-diesel
- Taxi-10 Fran SD bus - diesel

#DIV/0! means zero VMT

Calculation of NOX Emission Factor (gm/mile/vehicle) for each hours for BCF associated roads (cross-boundary vehicles)

Hour	MC-1	MC-3	MC-4	MC-5	MC-6	MC-7	MC-8	MC-10	MC-11	Taxi-3	Taxi-4	Taxi-5	Taxi-6	Taxi-7	Taxi-8	Taxi-10
0:00	1:00	0.101	#DIV/0!	0.224	#DIV/0!	1.294	2.372	3.078	#DIV/0!	#DIV/0!	#DIV/0!	#DIV/0!	#DIV/0!	#DIV/0!	#DIV/0!	#DIV/0!
1:00	2:00	0.101	#DIV/0!	0.221	#DIV/0!	1.295	2.371	3.077	#DIV/0!	#DIV/0!	#DIV/0!	#DIV/0!	1.283	2.363	3.058	#DIV/0!
2:00	3:00	0.101	#DIV/0!	#DIV/0!	#DIV/0!	1.297	2.373	3.081	#DIV/0!	#DIV/0!	#DIV/0!	#DIV/0!	1.282	2.363	3.057	#DIV/0!
3:00	4:00	0.101	#DIV/0!	#DIV/0!	#DIV/0!	1.296	2.376	3.085	#DIV/0!	#DIV/0!	#DIV/0!	#DIV/0!	1.289	2.364	3.061	#DIV/0!
4:00	5:00	0.102	#DIV/0!	#DIV/0!	#DIV/0!	1.302	2.379	3.089	#DIV/0!	#DIV/0!	#DIV/0!	#DIV/0!	1.289	2.366	3.064	#DIV/0!
5:00	6:00	0.102	#DIV/0!	0.223	#DIV/0!	1.302	2.384	3.094	#DIV/0!	#DIV/0!	#DIV/0!	#DIV/0!	1.289	2.372	3.070	#DIV/0!
6:00	7:00	0.102	#DIV/0!	0.224	#DIV/0!	1.302	2.386	3.095	#DIV/0!	#DIV/0!	#DIV/0!	#DIV/0!	1.289	2.374	3.074	#DIV/0!
7:00	8:00	0.103	#DIV/0!	0.226	#DIV/0!	1.302	2.385	3.096	#DIV/0!	#DIV/0!	#DIV/0!	#DIV/0!	1.297	2.376	3.076	#DIV/0!
8:00	9:00	0.103	#DIV/0!	0.227	#DIV/0!	1.304	2.390	3.101	#DIV/0!	#DIV/0!	#DIV/0!	#DIV/0!	1.296	2.377	3.076	#DIV/0!
9:00	10:00	0.103	#DIV/0!	0.227	#DIV/0!	1.305	2.391	3.103	#DIV/0!	#DIV/0!	#DIV/0!	#DIV/0!	1.296	2.381	3.081	#DIV/0!
10:00	11:00	0.103	#DIV/0!	0.227	#DIV/0!	1.304	2.388	3.100	#DIV/0!	#DIV/0!	#DIV/0!	#DIV/0!	1.296	2.382	3.083	#DIV/0!
11:00	12:00	0.103	#DIV/0!	0.226	#DIV/0!	1.304	2.389	3.100	#DIV/0!	#DIV/0!	#DIV/0!	#DIV/0!	1.296	2.380	3.080	#DIV/0!
12:00	13:00	0.104	#DIV/0!	0.226	#DIV/0!	1.304	2.389	3.100	#DIV/0!	#DIV/0!	#DIV/0!	#DIV/0!	1.296	2.380	3.080	#DIV/0!
13:00	14:00	0.103	#DIV/0!	0.226	#DIV/0!	1.302	2.385	3.096	#DIV/0!	#DIV/0!	#DIV/0!	#DIV/0!	1.295	2.381	3.080	#DIV/0!
14:00	15:00	0.103	#DIV/0!	0.227	#DIV/0!	1.300	2.381	3.090	#DIV/0!	#DIV/0!	#DIV/0!	#DIV/0!	1.294	2.377	3.076	#DIV/0!
15:00	16:00	0.103	#DIV/0!	0.227	#DIV/0!	1.300	2.381	3.090	#DIV/0!	#DIV/0!	#DIV/0!	#DIV/0!	1.293	2.373	3.070	#DIV/0!
16:00	17:00	0.102	#DIV/0!	0.226	#DIV/0!	1.300	2.381	3.090	#DIV/0!	#DIV/0!	#DIV/0!	#DIV/0!	1.293	2.373	3.070	#DIV/0!
17:00	18:00	0.102	#DIV/0!	0.225	#DIV/0!	1.298	2.378	3.087	#DIV/0!	#DIV/0!	#DIV/0!	#DIV/0!	1.293	2.373	3.071	#DIV/0!
18:00	19:00	0.101	#DIV/0!	0.226	#DIV/0!	1.297	2.376	3.083	#DIV/0!	#DIV/0!	#DIV/0!	#DIV/0!	1.290	2.370	3.067	#DIV/0!
19:00	20:00	0.101	#DIV/0!	0.226	#DIV/0!	1.297	2.376	3.083	#DIV/0!	#DIV/0!	#DIV/0!	#DIV/0!	1.288	2.368	3.064	#DIV/0!
20:00	21:00	0.101	#DIV/0!	0.227	#DIV/0!	1.298	2.377	3.085	#DIV/0!	#DIV/0!	#DIV/0!	#DIV/0!	1.290	2.368	3.064	#DIV/0!
21:00	22:00	0.101	#DIV/0!	0.227	#DIV/0!	1.297	2.375	3.082	#DIV/0!	#DIV/0!	#DIV/0!	#DIV/0!	1.290	2.369	3.065	#DIV/0!
22:00	23:00	0.101	#DIV/0!	0.230	#DIV/0!	1.295	2.374	3.080	#DIV/0!	#DIV/0!	#DIV/0!	#DIV/0!	1.289	2.366	3.062	#DIV/0!
23:00	0:00	0.101	#DIV/0!	0.230	#DIV/0!	1.295	2.373	3.079	#DIV/0!	#DIV/0!	#DIV/0!	#DIV/0!	1.286	2.365	3.061	#DIV/0!
Day		0.102	#DIV/0!	0.227	#DIV/0!	1.300	2.382	3.091	#DIV/0!	#DIV/0!	#DIV/0!	#DIV/0!	1.292	2.373	3.071	#DIV/0!

Note:

Vehicle classes

- MC-1 PC+LGV-petrol
- MC-3 PC+LGV<2.6-diesel
- MC-4 LGV2.6-3.5l-diesel
- MC-5 PLB (LPG/Diesel)
- MC-6 LGV>3.5l-diesel
- MC-7 HGV<15l-diesel
- MC-8 HGV>15l-diesel
- MC-10 Fran DD bus - diesel
- MC-11 Motorcycle -petrol
- Taxi-3 Taxi
- Taxi-4 PrLB<3.5l-diesel
- Taxi-5 PrLB>3.5l (LPG/Diesel)
- Taxi-6 Non-fran bus<6.4l-diesel
- Taxi-7 Non-fran bus<6.4-15l-diesel
- Taxi-8 Non-fran bus>15l-diesel
- Taxi-10 Fran SD bus - diesel

#DIV/0! means zero VMT

Calculation of RSP Emission Factor (gm/mile/vehicle) for each hours for BCF associated roads (cross-boundary vehicles)

Hour	MC-1	MC-3	MC-4	MC-5	MC-6	MC-7	MC-8	MC-10	MC-11	Taxi-3	Taxi-4	Taxi-5	Taxi-6	Taxi-7	Taxi-8	Taxi-10	
0:00	1:00	0.004	#DIV/0!	0.061	#DIV/0!	0.054	0.075	0.069	#DIV/0!	#DIV/0!	#DIV/0!	#DIV/0!	#DIV/0!	0.037	0.071	0.062	#DIV/0!
1:00	2:00	0.004	#DIV/0!	0.066	#DIV/0!	0.053	0.076	0.069	#DIV/0!	#DIV/0!	#DIV/0!	#DIV/0!	#DIV/0!	0.040	0.072	0.062	#DIV/0!
2:00	3:00	0.004	#DIV/0!	#DIV/0!	#DIV/0!	0.052	0.075	0.069	#DIV/0!	#DIV/0!	#DIV/0!	#DIV/0!	#DIV/0!	0.038	0.071	0.062	#DIV/0!
3:00	4:00	0.004	#DIV/0!	#DIV/0!	#DIV/0!	0.050	0.075	0.069	#DIV/0!	#DIV/0!	#DIV/0!	#DIV/0!	#DIV/0!	0.038	0.068	0.062	#DIV/0!
4:00	5:00	0.003	#DIV/0!	#DIV/0!	#DIV/0!	0.050	0.075	0.069	#DIV/0!	#DIV/0!	#DIV/0!	#DIV/0!	#DIV/0!	0.038	0.068	0.062	#DIV/0!
5:00	6:00	0.004	#DIV/0!	0.056	#DIV/0!	0.054	0.076	0.069	#DIV/0!	#DIV/0!	#DIV/0!	#DIV/0!	#DIV/0!	0.038	0.068	0.062	#DIV/0!
6:00	7:00	0.004	#DIV/0!	0.061	#DIV/0!	0.053	0.075	0.069	#DIV/0!	#DIV/0!	#DIV/0!	#DIV/0!	#DIV/0!	0.038	0.073	0.062	#DIV/0!
7:00	8:00	0.004	#DIV/0!	0.062	#DIV/0!	0.053	0.076	0.069	#DIV/0!	#DIV/0!	#DIV/0!	#DIV/0!	#DIV/0!	0.038	0.071	0.062	#DIV/0!
8:00	9:00	0.004	#DIV/0!	0.059	#DIV/0!	0.053	0.076	0.069	#DIV/0!	#DIV/0!	#DIV/0!	#DIV/0!	#DIV/0!	0.038	0.071	0.062	#DIV/0!
9:00	10:00	0.004	#DIV/0!	0.059	#DIV/0!	0.053	0.076	0.069	#DIV/0!	#DIV/0!	#DIV/0!	#DIV/0!	#DIV/0!	0.038	0.071	0.062	#DIV/0!
10:00	11:00	0.004	#DIV/0!	0.059	#DIV/0!	0.053	0.076	0.069	#DIV/0!	#DIV/0!	#DIV/0!	#DIV/0!	#DIV/0!	0.038	0.071	0.062	#DIV/0!
11:00	12:00	0.004	#DIV/0!	0.059	#DIV/0!	0.053	0.076	0.069	#DIV/0!	#DIV/0!	#DIV/0!	#DIV/0!	#DIV/0!	0.038	0.072	0.062	#DIV/0!
12:00	13:00	0.004	#DIV/0!	0.059	#DIV/0!	0.053	0.076	0.069	#DIV/0!	#DIV/0!	#DIV/0!	#DIV/0!	#DIV/0!	0.041	0.071	0.062	#DIV/0!
13:00	14:00	0.004	#DIV/0!	0.059	#DIV/0!	0.053	0.076	0.069	#DIV/0!	#DIV/0!	#DIV/0!	#DIV/0!	#DIV/0!	0.038	0.071	0.062	#DIV/0!
14:00	15:00	0.004	#DIV/0!	0.059	#DIV/0!	0.053	0.076	0.069	#DIV/0!	#DIV/0!	#DIV/0!	#DIV/0!	#DIV/0!	0.039	0.071	0.062	#DIV/0!
15:00	16:00	0.004	#DIV/0!	0.059	#DIV/0!	0.053	0.076	0.069	#DIV/0!	#DIV/0!	#DIV/0!	#DIV/0!	#DIV/0!	0.038	0.071	0.062	#DIV/0!
16:00	17:00	0.004	#DIV/0!	0.059	#DIV/0!	0.053	0.076	0.069	#DIV/0!	#DIV/0!	#DIV/0!	#DIV/0!	#DIV/0!	0.041	0.072	0.062	#DIV/0!
17:00	18:00	0.004	#DIV/0!	0.061	#DIV/0!	0.053	0.076	0.069	#DIV/0!	#DIV/0!	#DIV/0!	#DIV/0!	#DIV/0!	0.041	0.071	0.062	#DIV/0!
18:00	19:00	0.004	#DIV/0!	0.059	#DIV/0!	0.053	0.076	0.069	#DIV/0!	#DIV/0!	#DIV/0!	#DIV/0!	#DIV/0!	0.038	0.071	0.062	#DIV/0!
19:00	20:00	0.004	#DIV/0!	0.059	#DIV/0!	0.053	0.076	0.069	#DIV/0!	#DIV/0!	#DIV/0!	#DIV/0!	#DIV/0!	0.039	0.071	0.062	#DIV/0!
20:00	21:00	0.004	#DIV/0!	0.059	#DIV/0!	0.053	0.076	0.069	#DIV/0!	#DIV/0!	#DIV/0!	#DIV/0!	#DIV/0!	0.041	0.071	0.062	#DIV/0!
21:00	22:00	0.004	#DIV/0!	0.059	#DIV/0!	0.053	0.076	0.069	#DIV/0!	#DIV/0!	#DIV/0!	#DIV/0!	#DIV/0!	0.038	0.071	0.063	#DIV/0!
22:00	23:00	0.004	#DIV/0!	0.057	#DIV/0!	0.053	0.076	0.069	#DIV/0!	#DIV/0!	#DIV/0!	#DIV/0!	#DIV/0!	0.037	0.071	0.062	#DIV/0!
23:00	0:00	0.004	#DIV/0!	0.057	#DIV/0!	0.053	0.076	0.069	#DIV/0!	#DIV/0!	#DIV/0!	#DIV/0!	#DIV/0!	0.037	0.071	0.062	#DIV/0!
	Day	0.004	#DIV/0!	0.058	#DIV/0!	0.053	0.076	0.069	#DIV/0!	#DIV/0!	#DIV/0!	#DIV/0!	#DIV/0!	0.039	0.071	0.062	#DIV/0!

Note:

Vehicle classes

- MC-1 PC+LGV-petrol
- MC-3 PC+LGV<2,6-diesel
- MC-4 LGV2,6-3,5t-diesel
- MC-5 PLB (LPG/Diesel)
- MC-6 LGV>3,5t-diesel
- MC-7 HGV<15t-diesel
- MC-8 HGV>15t-diesel
- MC-10 Fran DD bus - diesel
- MC-11 Motorcycle -petrol
- Taxi-3 Taxi
- Taxi-4 PrLB<3,5t-diesel
- Taxi-5 PrLB>3,5t (LPG/Diesel)
- Taxi-6 Non-fran bus<6,4t-diesel
- Taxi-7 Non-fran bus<6,4-15t-diesel
- Taxi-8 Non-fran bus>15t-diesel
- Taxi-10 Fran SD bus - diesel

#DIV/0! means zero VMT

Calculation of NOX Emission Factor (gm/mile/vehicle) for each hours for HKRL (cross-boundary vehicles)

Hour	MC-1	MC-3	MC-4	MC-5	MC-6	MC-7	MC-8	MC-10	MC-11	Taxi-3	Taxi-4	Taxi-5	Taxi-6	Taxi-7	Taxi-8	Taxi-10	
0:00	1:00	0.098	#DIV/0!	0.404	#DIV/0!	2.320	2.500	3.244	#DIV/0!	#DIV/0!	#DIV/0!	#DIV/0!	#DIV/0!	1.356	2.491	3.223	#DIV/0!
1:00	2:00	0.098	#DIV/0!	0.404	#DIV/0!	2.320	2.499	3.243	#DIV/0!	#DIV/0!	#DIV/0!	#DIV/0!	#DIV/0!	1.357	2.490	3.222	#DIV/0!
2:00	3:00	0.099	#DIV/0!	#DIV/0!	#DIV/0!	2.322	2.503	3.247	#DIV/0!	#DIV/0!	#DIV/0!	#DIV/0!	#DIV/0!	1.359	2.494	3.226	#DIV/0!
3:00	4:00	0.099	#DIV/0!	#DIV/0!	#DIV/0!	2.326	2.504	3.251	#DIV/0!	#DIV/0!	#DIV/0!	#DIV/0!	#DIV/0!	1.359	2.495	3.230	#DIV/0!
4:00	5:00	0.099	#DIV/0!	#DIV/0!	#DIV/0!	2.329	2.509	3.256	#DIV/0!	#DIV/0!	#DIV/0!	#DIV/0!	#DIV/0!	1.359	2.501	3.235	#DIV/0!
5:00	6:00	0.099	#DIV/0!	0.407	#DIV/0!	2.333	2.513	3.261	#DIV/0!	#DIV/0!	#DIV/0!	#DIV/0!	#DIV/0!	1.365	2.503	3.240	#DIV/0!
6:00	7:00	0.100	#DIV/0!	0.410	#DIV/0!	2.334	2.514	3.262	#DIV/0!	#DIV/0!	#DIV/0!	#DIV/0!	#DIV/0!	1.363	2.505	3.242	#DIV/0!
7:00	8:00	0.100	#DIV/0!	0.407	#DIV/0!	2.334	2.514	3.263	#DIV/0!	#DIV/0!	#DIV/0!	#DIV/0!	#DIV/0!	1.364	2.505	3.242	#DIV/0!
8:00	9:00	0.100	#DIV/0!	0.407	#DIV/0!	2.338	2.518	3.268	#DIV/0!	#DIV/0!	#DIV/0!	#DIV/0!	#DIV/0!	1.364	2.505	3.242	#DIV/0!
9:00	10:00	0.100	#DIV/0!	0.407	#DIV/0!	2.339	2.520	3.270	#DIV/0!	#DIV/0!	#DIV/0!	#DIV/0!	#DIV/0!	1.366	2.509	3.247	#DIV/0!
10:00	11:00	0.100	#DIV/0!	0.407	#DIV/0!	2.337	2.517	3.267	#DIV/0!	#DIV/0!	#DIV/0!	#DIV/0!	#DIV/0!	1.366	2.511	3.249	#DIV/0!
11:00	12:00	0.100	#DIV/0!	0.407	#DIV/0!	2.337	2.517	3.267	#DIV/0!	#DIV/0!	#DIV/0!	#DIV/0!	#DIV/0!	1.366	2.508	3.246	#DIV/0!
12:00	13:00	0.101	#DIV/0!	0.407	#DIV/0!	2.337	2.517	3.267	#DIV/0!	#DIV/0!	#DIV/0!	#DIV/0!	#DIV/0!	1.366	2.508	3.246	#DIV/0!
13:00	14:00	0.101	#DIV/0!	0.407	#DIV/0!	2.334	2.514	3.263	#DIV/0!	#DIV/0!	#DIV/0!	#DIV/0!	#DIV/0!	1.366	2.509	3.246	#DIV/0!
14:00	15:00	0.100	#DIV/0!	0.407	#DIV/0!	2.330	2.509	3.257	#DIV/0!	#DIV/0!	#DIV/0!	#DIV/0!	#DIV/0!	1.364	2.505	3.242	#DIV/0!
15:00	16:00	0.100	#DIV/0!	0.407	#DIV/0!	2.330	2.509	3.257	#DIV/0!	#DIV/0!	#DIV/0!	#DIV/0!	#DIV/0!	1.361	2.501	3.236	#DIV/0!
16:00	17:00	0.100	#DIV/0!	0.407	#DIV/0!	2.330	2.510	3.257	#DIV/0!	#DIV/0!	#DIV/0!	#DIV/0!	#DIV/0!	1.361	2.501	3.236	#DIV/0!
17:00	18:00	0.099	#DIV/0!	0.406	#DIV/0!	2.327	2.507	3.253	#DIV/0!	#DIV/0!	#DIV/0!	#DIV/0!	#DIV/0!	1.361	2.501	3.236	#DIV/0!
18:00	19:00	0.099	#DIV/0!	0.404	#DIV/0!	2.324	2.504	3.249	#DIV/0!	#DIV/0!	#DIV/0!	#DIV/0!	#DIV/0!	1.359	2.498	3.232	#DIV/0!
19:00	20:00	0.099	#DIV/0!	0.404	#DIV/0!	2.325	2.504	3.250	#DIV/0!	#DIV/0!	#DIV/0!	#DIV/0!	#DIV/0!	1.358	2.495	3.229	#DIV/0!
20:00	21:00	0.099	#DIV/0!	0.407	#DIV/0!	2.326	2.505	3.251	#DIV/0!	#DIV/0!	#DIV/0!	#DIV/0!	#DIV/0!	1.359	2.496	3.230	#DIV/0!
21:00	22:00	0.099	#DIV/0!	0.407	#DIV/0!	2.323	2.503	3.248	#DIV/0!	#DIV/0!	#DIV/0!	#DIV/0!	#DIV/0!	1.358	2.494	3.227	#DIV/0!
22:00	23:00	0.098	#DIV/0!	0.404	#DIV/0!	2.322	2.502	3.247	#DIV/0!	#DIV/0!	#DIV/0!	#DIV/0!	#DIV/0!	1.358	2.494	3.227	#DIV/0!
23:00	0:00	0.098	#DIV/0!	0.404	#DIV/0!	2.321	2.501	3.245	#DIV/0!	#DIV/0!	#DIV/0!	#DIV/0!	#DIV/0!	1.356	2.493	3.226	#DIV/0!
	Day	0.100	#DIV/0!	0.406	#DIV/0!	2.330	2.510	3.258	#DIV/0!	#DIV/0!	#DIV/0!	#DIV/0!	#DIV/0!	1.362	2.501	3.237	#DIV/0!

Note:

Vehicle classes

- MC-1 PC+LGV-petrol
- MC-3 PC+LGV<2.6-diesel
- MC-4 LGV2.6-3.5t-diesel
- MC-5 PLB (LPG/Diesel)
- MC-6 LGV>3.5t-diesel
- MC-7 HGV<15t-diesel
- MC-8 HGV>15t-diesel
- MC-10 Fran DD bus - diesel
- MC-11 Motorcycle - petrol
- Taxi-3 Taxi
- Taxi-4 PrLB<3.5t-diesel
- Taxi-5 PrLB>3.5t (LPG/Diesel)
- Taxi-6 Non-fran bus<6.4t-diesel
- Taxi-7 Non-fran bus<6.4-15t-diesel
- Taxi-8 Non-fran bus>15t-diesel
- Taxi-10 Fran SD bus - diesel

#DIV/0! means zero VMT

Calculation of RSP Emission Factor (gm/mile/vehicle) for each hours for HKRL (cross-boundary vehicles)

Hour	MC-1	MC-3	MC-4	MC-5	MC-6	MC-7	MC-8	MC-10	MC-11	Taxi-3	Taxi-4	Taxi-5	Taxi-6	Taxi-7	Taxi-8	Taxi-10	
0:00	1:00	0.003	#DIV/0!	0.042	#DIV/0!	0.036	0.061	0.056	#DIV/0!	#DIV/0!	#DIV/0!	#DIV/0!	#DIV/0!	#DIV/0!	#DIV/0!	#DIV/0!	
1:00	2:00	0.003	#DIV/0!	0.042	#DIV/0!	0.036	0.061	0.056	#DIV/0!	#DIV/0!	#DIV/0!	#DIV/0!	#DIV/0!	0.032	0.057	0.050	#DIV/0!
2:00	3:00	0.003	#DIV/0!	#DIV/0!	#DIV/0!	0.036	0.061	0.056	#DIV/0!	#DIV/0!	#DIV/0!	#DIV/0!	#DIV/0!	0.032	0.057	0.050	#DIV/0!
3:00	4:00	0.003	#DIV/0!	#DIV/0!	#DIV/0!	0.036	0.050	0.056	#DIV/0!	#DIV/0!	#DIV/0!	#DIV/0!	#DIV/0!	0.030	0.058	0.050	#DIV/0!
4:00	5:00	0.003	#DIV/0!	#DIV/0!	#DIV/0!	0.036	0.060	0.056	#DIV/0!	#DIV/0!	#DIV/0!	#DIV/0!	#DIV/0!	0.030	0.057	0.050	#DIV/0!
5:00	6:00	0.003	#DIV/0!	0.036	#DIV/0!	0.036	0.061	0.056	#DIV/0!	#DIV/0!	#DIV/0!	#DIV/0!	#DIV/0!	0.030	0.057	0.050	#DIV/0!
6:00	7:00	0.003	#DIV/0!	0.042	#DIV/0!	0.036	0.061	0.056	#DIV/0!	#DIV/0!	#DIV/0!	#DIV/0!	#DIV/0!	0.030	0.057	0.050	#DIV/0!
7:00	8:00	0.003	#DIV/0!	0.039	#DIV/0!	0.036	0.061	0.056	#DIV/0!	#DIV/0!	#DIV/0!	#DIV/0!	#DIV/0!	0.031	0.057	0.050	#DIV/0!
8:00	9:00	0.003	#DIV/0!	0.039	#DIV/0!	0.036	0.061	0.056	#DIV/0!	#DIV/0!	#DIV/0!	#DIV/0!	#DIV/0!	0.032	0.057	0.050	#DIV/0!
9:00	10:00	0.003	#DIV/0!	0.039	#DIV/0!	0.036	0.061	0.056	#DIV/0!	#DIV/0!	#DIV/0!	#DIV/0!	#DIV/0!	0.031	0.057	0.050	#DIV/0!
10:00	11:00	0.003	#DIV/0!	0.039	#DIV/0!	0.036	0.061	0.056	#DIV/0!	#DIV/0!	#DIV/0!	#DIV/0!	#DIV/0!	0.031	0.057	0.050	#DIV/0!
11:00	12:00	0.003	#DIV/0!	0.040	#DIV/0!	0.036	0.061	0.056	#DIV/0!	#DIV/0!	#DIV/0!	#DIV/0!	#DIV/0!	0.032	0.057	0.050	#DIV/0!
12:00	13:00	0.003	#DIV/0!	0.040	#DIV/0!	0.036	0.061	0.056	#DIV/0!	#DIV/0!	#DIV/0!	#DIV/0!	#DIV/0!	0.032	0.057	0.050	#DIV/0!
13:00	14:00	0.003	#DIV/0!	0.040	#DIV/0!	0.036	0.061	0.056	#DIV/0!	#DIV/0!	#DIV/0!	#DIV/0!	#DIV/0!	0.032	0.057	0.050	#DIV/0!
14:00	15:00	0.003	#DIV/0!	0.039	#DIV/0!	0.036	0.061	0.056	#DIV/0!	#DIV/0!	#DIV/0!	#DIV/0!	#DIV/0!	0.031	0.057	0.050	#DIV/0!
15:00	16:00	0.003	#DIV/0!	0.039	#DIV/0!	0.036	0.061	0.056	#DIV/0!	#DIV/0!	#DIV/0!	#DIV/0!	#DIV/0!	0.032	0.057	0.050	#DIV/0!
16:00	17:00	0.003	#DIV/0!	0.040	#DIV/0!	0.036	0.061	0.056	#DIV/0!	#DIV/0!	#DIV/0!	#DIV/0!	#DIV/0!	0.032	0.057	0.050	#DIV/0!
17:00	18:00	0.003	#DIV/0!	0.040	#DIV/0!	0.036	0.061	0.056	#DIV/0!	#DIV/0!	#DIV/0!	#DIV/0!	#DIV/0!	0.032	0.057	0.050	#DIV/0!
18:00	19:00	0.003	#DIV/0!	0.040	#DIV/0!	0.036	0.061	0.056	#DIV/0!	#DIV/0!	#DIV/0!	#DIV/0!	#DIV/0!	0.032	0.057	0.050	#DIV/0!
19:00	20:00	0.003	#DIV/0!	0.040	#DIV/0!	0.036	0.061	0.056	#DIV/0!	#DIV/0!	#DIV/0!	#DIV/0!	#DIV/0!	0.031	0.057	0.050	#DIV/0!
20:00	21:00	0.003	#DIV/0!	0.039	#DIV/0!	0.036	0.061	0.056	#DIV/0!	#DIV/0!	#DIV/0!	#DIV/0!	#DIV/0!	0.032	0.057	0.050	#DIV/0!
21:00	22:00	0.003	#DIV/0!	0.039	#DIV/0!	0.036	0.061	0.056	#DIV/0!	#DIV/0!	#DIV/0!	#DIV/0!	#DIV/0!	0.031	0.057	0.050	#DIV/0!
22:00	23:00	0.003	#DIV/0!	0.042	#DIV/0!	0.036	0.061	0.056	#DIV/0!	#DIV/0!	#DIV/0!	#DIV/0!	#DIV/0!	0.032	0.057	0.050	#DIV/0!
23:00	0:00	0.003	#DIV/0!	0.042	#DIV/0!	0.036	0.061	0.056	#DIV/0!	#DIV/0!	#DIV/0!	#DIV/0!	#DIV/0!	0.031	0.057	0.050	#DIV/0!
Day		0.003	#DIV/0!	0.039	#DIV/0!	0.036	0.061	0.056	#DIV/0!	#DIV/0!	#DIV/0!	#DIV/0!	#DIV/0!	0.032	0.057	0.050	#DIV/0!

Note:

Vehicle classes

- MC-1 PC+LGV-petrol
- MC-3 PC+LGV<2.6-diesel
- MC-4 LGV2.6-3.5t-diesel
- MC-5 PLB (LPG/Diesel)
- MC-6 LGV>3.5t-diesel
- MC-7 HGV<15t-diesel
- MC-8 HGV>15t-diesel
- MC-10 Fran DD bus - diesel
- MC-11 Motorcycle -petrol
- Taxi-3 Taxi
- Taxi-4 PrLB<3.5t-diesel
- Taxi-5 PrLB>3.5t (LPG/Diesel)
- Taxi-6 Non-fran bus<6.4t-diesel
- Taxi-7 Non-fran bus<6.4-15t-diesel
- Taxi-8 Non-fran bus>15t-diesel
- Taxi-10 Fran SD bus - diesel

#DIV/0! means zero VMT

Calculation of NOX Emission Factor (gm/mile/vehicle) for each hours for NLH and Airport Road

Hour	MC-1	MC-3	MC-4	MC-5	MC-6	MC-7	MC-8	MC-10	MC-11	Taxi-3	Taxi-4	Taxi-5	Taxi-6	Taxi-7	Taxi-8	Taxi-10	
0:00	1:00	0.111	0.505	0.501	0.228	2.885	2.511	3.262	1.994	1.331	0.290	#DIV/0!	#DIV/0!	1.357	2.481	3.253	1.536
1:00	2:00	0.111	0.504	0.500	0.246	2.884	2.510	3.261	1.993	1.332	0.290	#DIV/0!	#DIV/0!	1.356	2.480	3.251	1.528
2:00	3:00	0.111	0.505	0.501	0.240	2.888	2.513	3.265	1.996	1.338	0.291	#DIV/0!	#DIV/0!	1.358	2.484	3.257	#DIV/0!
3:00	4:00	0.112	0.507	0.502	0.202	2.891	2.516	3.269	1.998	1.342	0.292	#DIV/0!	#DIV/0!	1.360	2.485	3.261	#DIV/0!
4:00	5:00	0.112	0.506	0.503	0.241	2.896	2.520	3.274	2.002	1.348	0.293	#DIV/0!	#DIV/0!	1.362	2.490	3.264	#DIV/0!
5:00	6:00	0.112	0.508	0.503	0.229	2.900	2.524	3.279	2.004	1.352	0.294	#DIV/0!	#DIV/0!	1.364	2.494	3.270	#DIV/0!
6:00	7:00	0.113	0.508	0.504	0.241	2.902	2.525	3.280	2.005	1.353	0.294	#DIV/0!	#DIV/0!	1.364	2.495	3.272	1.542
7:00	8:00	0.109	0.386	0.384	0.189	2.210	2.525	3.281	2.006	1.287	0.284	0.385	0.326	1.364	2.495	3.272	1.541
8:00	9:00	0.109	0.387	0.384	0.190	2.214	2.529	3.286	2.009	1.286	0.284	0.386	0.329	1.367	2.499	3.278	1.545
9:00	10:00	0.109	0.387	0.384	0.190	2.215	2.531	3.288	2.010	1.281	0.285	0.386	0.328	1.367	2.501	3.279	1.544
10:00	11:00	0.109	0.386	0.384	0.188	2.213	2.528	3.285	2.008	1.274	0.285	0.386	0.329	1.366	2.498	3.276	1.542
11:00	12:00	0.109	0.386	0.384	0.189	2.213	2.528	3.285	2.008	1.270	0.285	0.386	0.332	1.366	2.498	3.276	1.543
12:00	13:00	0.110	0.387	0.384	0.191	2.213	2.529	3.285	2.008	1.268	0.286	0.386	0.330	1.366	2.498	3.276	1.543
13:00	14:00	0.109	0.386	0.384	0.190	2.210	2.525	3.281	2.005	1.263	0.286	0.385	0.330	1.364	2.495	3.272	1.541
14:00	15:00	0.109	0.385	0.383	0.188	2.206	2.520	3.275	2.002	1.258	0.285	0.385	0.329	1.362	2.490	3.266	1.538
15:00	16:00	0.109	0.385	0.383	0.189	2.206	2.521	3.275	2.002	1.259	0.284	0.384	0.328	1.362	2.490	3.266	1.538
16:00	17:00	0.109	0.385	0.383	0.188	2.206	2.521	3.275	2.002	1.261	0.283	0.385	0.330	1.362	2.491	3.266	1.540
17:00	18:00	0.108	0.385	0.382	0.188	2.204	2.518	3.271	1.999	1.262	0.282	0.384	0.331	1.360	2.488	3.262	1.537
18:00	19:00	0.107	0.384	0.382	0.191	2.201	2.515	3.267	1.997	1.263	0.280	0.384	0.326	1.359	2.485	3.259	1.536
19:00	20:00	0.107	0.385	0.382	0.191	2.201	2.515	3.268	1.997	1.264	0.280	#DIV/0!	#DIV/0!	1.359	2.485	3.259	1.536
20:00	21:00	0.107	0.385	0.382	0.188	2.202	2.516	3.269	1.998	1.268	0.280	#DIV/0!	#DIV/0!	1.359	2.486	3.260	1.536
21:00	22:00	0.107	0.384	0.382	0.188	2.200	2.514	3.266	1.996	1.267	0.280	#DIV/0!	#DIV/0!	1.358	2.484	3.257	1.533
22:00	23:00	0.107	0.384	0.382	0.190	2.199	2.513	3.264	1.996	1.268	0.280	#DIV/0!	#DIV/0!	1.358	2.483	3.256	1.533
23:00	0:00	0.111	0.505	0.501	0.234	2.886	2.512	3.263	1.995	1.329	0.290	#DIV/0!	#DIV/0!	1.357	2.482	3.255	1.532
	Day	0.109	0.401	0.398	0.195	2.294	2.521	3.276	2.002	1.278	0.284	0.385	0.329	1.362	2.491	3.267	1.539

Note:

Vehicle classes

- MC-1 PC+LGV-petrol
- MC-3 PC+LGV<2.6-diesel
- MC-4 LGV2.6-3.5t-diesel
- MC-5 PLB (LPG/Diesel)
- MC-6 LGV>3.5t-diesel
- MC-7 HGV<15t-diesel
- MC-8 HGV>15t-diesel
- MC-10 Fran DD bus - diesel
- MC-11 Motorcycle -petrol
- Taxi-3 Taxi
- Taxi-4 PrLB<3.5t-diesel
- Taxi-5 PrLB>3.5t (LPG/Diesel)
- Taxi-6 Non-fran bus<6.4t-diesel
- Taxi-7 Non-fran bus<6.4-15t-diesel
- Taxi-8 Non-fran bus>15t-diesel
- Taxi-10 Fran SD bus - diesel

#DIV/0! means zero VMT

Calculation of RSP Emission Factor (gm/mile/vehicle) for each hours for NLH and Airport Road

Hour	MC-1	MC-3	MC-4	MC-5	MC-6	MC-7	MC-8	MC-10	MC-11	Taxi-3	Taxi-4	Taxi-5	Taxi-6	Taxi-7	Taxi-8	Taxi-10	
0:00	1:00	0.005	0.056	0.043	0.056	0.042	0.065	0.059	0.036	0.107	0.028	#DIV/0!	#DIV/0!	0.037	0.057	0.053	0.036
1:00	2:00	0.005	0.056	0.043	0.059	0.042	0.065	0.059	0.036	0.107	0.028	#DIV/0!	#DIV/0!	0.037	0.058	0.054	0.036
2:00	3:00	0.005	0.055	0.043	0.058	0.042	0.065	0.059	0.036	0.107	0.028	#DIV/0!	#DIV/0!	0.037	0.057	0.054	#DIV/0!
3:00	4:00	0.005	0.055	0.043	0.053	0.042	0.065	0.059	0.037	0.107	0.028	#DIV/0!	#DIV/0!	0.037	0.057	0.055	#DIV/0!
4:00	5:00	0.005	0.054	0.043	0.060	0.042	0.065	0.059	0.036	0.107	0.028	#DIV/0!	#DIV/0!	0.037	0.057	0.053	#DIV/0!
5:00	6:00	0.005	0.056	0.043	0.056	0.042	0.065	0.059	0.036	0.107	0.028	#DIV/0!	#DIV/0!	0.037	0.057	0.054	0.036
6:00	7:00	0.005	0.055	0.043	0.058	0.042	0.065	0.059	0.036	0.107	0.028	#DIV/0!	#DIV/0!	0.037	0.057	0.053	0.039
7:00	8:00	0.004	0.056	0.044	0.057	0.043	0.065	0.059	0.036	0.079	0.025	0.077	0.090	0.037	0.057	0.053	0.038
8:00	9:00	0.004	0.056	0.044	0.057	0.043	0.065	0.059	0.036	0.079	0.025	0.077	0.090	0.037	0.057	0.053	0.038
9:00	10:00	0.004	0.056	0.044	0.057	0.043	0.065	0.059	0.036	0.079	0.025	0.077	0.090	0.037	0.057	0.053	0.038
10:00	11:00	0.004	0.056	0.044	0.057	0.043	0.065	0.059	0.036	0.079	0.025	0.077	0.091	0.037	0.057	0.053	0.038
11:00	12:00	0.004	0.056	0.044	0.057	0.043	0.065	0.059	0.036	0.079	0.025	0.077	0.091	0.037	0.057	0.053	0.038
12:00	13:00	0.004	0.056	0.044	0.057	0.043	0.065	0.059	0.036	0.079	0.025	0.077	0.091	0.037	0.057	0.053	0.038
13:00	14:00	0.004	0.056	0.044	0.057	0.043	0.065	0.059	0.036	0.079	0.025	0.077	0.091	0.037	0.057	0.053	0.038
14:00	15:00	0.004	0.056	0.044	0.057	0.043	0.065	0.059	0.036	0.079	0.025	0.077	0.091	0.037	0.057	0.053	0.038
15:00	16:00	0.004	0.056	0.044	0.057	0.043	0.065	0.059	0.036	0.079	0.025	0.077	0.091	0.037	0.057	0.053	0.038
16:00	17:00	0.004	0.056	0.044	0.057	0.043	0.065	0.059	0.036	0.079	0.025	0.077	0.091	0.037	0.057	0.053	0.038
17:00	18:00	0.004	0.056	0.044	0.057	0.043	0.065	0.059	0.036	0.079	0.025	0.077	0.091	0.037	0.057	0.053	0.038
18:00	19:00	0.004	0.056	0.044	0.057	0.043	0.065	0.059	0.036	0.079	0.025	0.077	0.091	0.037	0.057	0.053	0.038
19:00	20:00	0.004	0.056	0.044	0.058	0.043	0.065	0.059	0.036	0.079	0.025	#DIV/0!	#DIV/0!	0.037	0.057	0.053	0.038
20:00	21:00	0.004	0.056	0.044	0.057	0.043	0.065	0.059	0.036	0.079	0.025	#DIV/0!	#DIV/0!	0.037	0.057	0.053	0.038
21:00	22:00	0.004	0.056	0.044	0.057	0.043	0.065	0.059	0.036	0.079	0.025	#DIV/0!	#DIV/0!	0.037	0.057	0.053	0.038
22:00	23:00	0.004	0.056	0.044	0.057	0.043	0.065	0.059	0.036	0.079	0.025	#DIV/0!	#DIV/0!	0.037	0.057	0.053	0.038
23:00	0:00	0.005	0.055	0.043	0.057	0.042	0.065	0.059	0.036	0.107	0.028	#DIV/0!	#DIV/0!	0.037	0.057	0.053	0.038
	Day	0.004	0.056	0.044	0.057	0.043	0.065	0.059	0.036	0.083	0.025	0.076	0.091	0.037	0.057	0.053	0.038

Note:

Vehicle classes

- MC-1 PC+LGV-petrol
- MC-3 PC+LGV<2.6-diesel
- MC-4 LGV2.6-3.5l-diesel
- MC-5 PLB (LPG/Diesel)
- MC-6 LGV>3.5l-diesel
- MC-7 HGV<15t-diesel
- MC-8 HGV>15t-diesel
- MC-10 Fran DD bus - diesel
- MC-11 Motorcycle -petrol
- Taxi-3 Taxi
- Taxi-4 PrLB<3.5t-diesel
- Taxi-5 PrLB>3.5l (LPG/Diesel)
- Taxi-6 Non-fran bus<6.4t-diesel
- Taxi-7 Non-fran bus<6.4-15l-diesel
- Taxi-8 Non-fran bus>15l-diesel
- Taxi-10 Fran SD bus - diesel

#DIV/0! means zero VMT

Calculation of NOX Emission Factor (gm/mile/vehicle) for each hours for other roads

Hour	MC-1	MC-3	MC-4	MC-5	MC-6	MC-7	MC-8	MC-10	MC-11	Taxi-3	Taxi-4	Taxi-5	Taxi-6	Taxi-7	Taxi-8	Taxi-10	
0:00	1:00	0.129	0.228	0.226	0.109	1.300	2.384	3.097	1.877	1.205	0.300	#DIV/0!	#DIV/0!	1.292	2.361	3.097	1.444
1:00	2:00	0.129	0.228	0.226	0.108	1.300	2.383	3.096	1.877	1.216	0.301	#DIV/0!	#DIV/0!	1.291	2.361	3.096	1.442
2:00	3:00	0.131	0.231	0.226	0.110	1.301	2.386	3.100	1.880	1.234	0.302	#DIV/0!	#DIV/0!	1.293	2.364	3.101	1.447
3:00	4:00	0.130	0.230	0.226	0.110	1.303	2.389	3.104	1.882	1.224	0.302	#DIV/0!	#DIV/0!	1.294	2.366	3.104	1.441
4:00	5:00	0.129	0.226	0.226	0.111	1.305	2.393	3.109	1.884	1.194	0.303	#DIV/0!	#DIV/0!	1.297	2.371	3.110	1.450
5:00	6:00	0.129	0.227	0.227	0.108	1.307	2.396	3.113	1.887	1.180	0.303	#DIV/0!	#DIV/0!	1.298	2.374	3.113	1.450
6:00	7:00	0.129	0.228	0.227	0.108	1.307	2.397	3.115	1.888	1.176	0.304	#DIV/0!	#DIV/0!	1.299	2.375	3.115	1.451
7:00	8:00	0.138	0.244	0.243	0.116	1.401	2.569	3.337	2.122	1.135	0.331	0.240	0.205	1.373	2.511	3.294	1.632
8:00	9:00	0.138	0.245	0.243	0.117	1.403	2.573	3.343	2.125	1.143	0.332	0.240	0.204	1.375	2.515	3.299	1.636
9:00	10:00	0.139	0.245	0.244	0.116	1.404	2.575	3.345	2.126	1.158	0.333	0.240	0.204	1.376	2.516	3.301	1.636
10:00	11:00	0.139	0.245	0.243	0.117	1.403	2.572	3.342	2.124	1.161	0.333	0.240	0.204	1.374	2.514	3.298	1.635
11:00	12:00	0.140	0.245	0.243	0.116	1.403	2.572	3.341	2.124	1.163	0.334	0.240	0.203	1.374	2.514	3.298	1.635
12:00	13:00	0.140	0.245	0.243	0.116	1.403	2.572	3.342	2.124	1.163	0.335	0.240	0.205	1.375	2.514	3.298	1.635
13:00	14:00	0.140	0.244	0.243	0.116	1.401	2.569	3.337	2.121	1.160	0.334	0.240	0.205	1.373	2.510	3.294	1.633
14:00	15:00	0.140	0.244	0.243	0.116	1.398	2.564	3.331	2.118	1.159	0.333	0.239	0.203	1.370	2.506	3.288	1.630
15:00	16:00	0.139	0.244	0.243	0.116	1.398	2.564	3.331	2.118	1.157	0.332	0.239	0.202	1.370	2.506	3.288	1.629
16:00	17:00	0.139	0.244	0.243	0.116	1.398	2.564	3.331	2.118	1.161	0.331	0.239	0.203	1.370	2.506	3.288	1.630
17:00	18:00	0.138	0.243	0.242	0.116	1.397	2.561	3.327	2.115	1.160	0.330	0.239	0.204	1.369	2.503	3.284	1.627
18:00	19:00	0.138	0.244	0.242	0.115	1.395	2.558	3.323	2.113	1.165	0.328	0.239	0.202	1.367	2.500	3.280	1.626
19:00	20:00	0.138	0.243	0.242	0.116	1.395	2.559	3.324	2.113	1.172	0.328	#DIV/0!	#DIV/0!	1.367	2.501	3.281	1.627
20:00	21:00	0.130	0.228	0.226	0.109	1.303	2.389	3.104	1.882	1.220	0.302	#DIV/0!	#DIV/0!	1.294	2.367	3.104	1.446
21:00	22:00	0.130	0.227	0.226	0.109	1.302	2.387	3.101	1.880	1.218	0.301	#DIV/0!	#DIV/0!	1.293	2.365	3.102	1.444
22:00	23:00	0.130	0.228	0.226	0.109	1.301	2.386	3.100	1.879	1.216	0.301	#DIV/0!	#DIV/0!	1.293	2.364	3.100	1.444
23:00	0:00	0.129	0.228	0.226	0.109	1.301	2.385	3.099	1.878	1.208	0.301	#DIV/0!	#DIV/0!	1.292	2.363	3.099	1.442
	Day	0.136	0.240	0.238	0.114	1.373	2.518	3.272	2.055	1.171	0.324	0.240	0.204	1.351	2.470	3.241	1.581

Note:

Vehicle classes

- MC-1 PC+LGV-petrol
- MC-3 PC+LGV<2.6-diesel
- MC-4 LGV2.6-3.5t-diesel
- MC-5 PLB (LPG/Diesel)
- MC-6 LGV>3.5t-diesel
- MC-7 HGV<15t-diesel
- MC-8 HGV>15t-diesel
- MC-10 Fran DD bus - diesel
- MC-11 Motorcycle -petrol
- Taxi-3 Taxi
- Taxi-4 PrLB<3.5t-diesel
- Taxi-5 PrLB>3.5t (LPG/Diesel)
- Taxi-6 Non-fran bus<6.4t-diesel
- Taxi-7 Non-fran bus<6.4-15t-diesel
- Taxi-8 Non-fran bus>15t-diesel
- Taxi-10 Fran SD bus - diesel

#DIV/0! means zero VMT

Calculation of RSP Emission Factor (gm/mile/vehicle) for each hours for other roads

Hour	MC-1	MC-3	MC-4	MC-5	MC-6	MC-7	MC-8	MC-10	MC-11	Taxi-3	Taxi-4	Taxi-5	Taxi-6	Taxi-7	Taxi-8	Taxi-10	
0:00	1:00	0.005	0.081	0.063	0.074	0.062	0.081	0.073	0.044	0.049	0.028	#DIV/0!	#DIV/0!	0.045	0.071	0.065	0.047
1:00	2:00	0.005	0.081	0.063	0.074	0.062	0.081	0.073	0.044	0.048	0.028	#DIV/0!	#DIV/0!	0.045	0.071	0.066	0.049
2:00	3:00	0.005	0.083	0.063	0.074	0.062	0.080	0.073	0.044	0.050	0.028	#DIV/0!	#DIV/0!	0.046	0.070	0.066	0.044
3:00	4:00	0.005	0.084	0.063	0.074	0.062	0.081	0.073	0.044	0.050	0.028	#DIV/0!	#DIV/0!	0.045	0.070	0.065	0.048
4:00	5:00	0.005	0.080	0.063	0.075	0.062	0.081	0.073	0.044	0.056	0.028	#DIV/0!	#DIV/0!	0.045	0.071	0.066	0.049
5:00	6:00	0.005	0.081	0.063	0.073	0.062	0.081	0.073	0.044	0.058	0.028	#DIV/0!	#DIV/0!	0.045	0.070	0.066	0.048
6:00	7:00	0.005	0.081	0.063	0.073	0.062	0.081	0.073	0.044	0.057	0.028	#DIV/0!	#DIV/0!	0.045	0.070	0.066	0.048
7:00	8:00	0.007	0.101	0.079	0.088	0.077	0.101	0.091	0.059	0.059	0.039	0.130	0.150	0.054	0.085	0.079	0.063
8:00	9:00	0.007	0.101	0.079	0.089	0.077	0.101	0.091	0.059	0.056	0.039	0.130	0.149	0.055	0.085	0.079	0.064
9:00	10:00	0.006	0.101	0.079	0.088	0.077	0.101	0.091	0.059	0.056	0.039	0.130	0.149	0.054	0.085	0.079	0.063
10:00	11:00	0.006	0.101	0.079	0.089	0.077	0.101	0.091	0.059	0.052	0.039	0.130	0.149	0.054	0.085	0.079	0.063
11:00	12:00	0.006	0.101	0.079	0.089	0.077	0.101	0.091	0.059	0.051	0.039	0.130	0.149	0.054	0.085	0.079	0.063
12:00	13:00	0.006	0.101	0.079	0.089	0.077	0.101	0.091	0.059	0.050	0.039	0.130	0.149	0.054	0.085	0.079	0.063
13:00	14:00	0.006	0.101	0.079	0.089	0.077	0.101	0.091	0.059	0.050	0.039	0.130	0.150	0.055	0.085	0.079	0.064
14:00	15:00	0.006	0.101	0.079	0.088	0.077	0.101	0.091	0.059	0.049	0.039	0.130	0.150	0.054	0.085	0.079	0.064
15:00	16:00	0.006	0.101	0.079	0.089	0.077	0.101	0.091	0.059	0.050	0.039	0.129	0.149	0.054	0.085	0.079	0.064
16:00	17:00	0.006	0.101	0.079	0.088	0.077	0.101	0.091	0.059	0.050	0.039	0.130	0.149	0.054	0.085	0.079	0.063
17:00	18:00	0.006	0.101	0.079	0.089	0.077	0.101	0.091	0.059	0.050	0.039	0.129	0.149	0.054	0.085	0.079	0.064
18:00	19:00	0.006	0.101	0.079	0.088	0.077	0.101	0.091	0.059	0.051	0.039	0.130	0.150	0.054	0.085	0.079	0.064
19:00	20:00	0.006	0.101	0.079	0.089	0.077	0.101	0.091	0.059	0.050	0.039	0.130	0.149	0.054	0.085	0.079	0.063
20:00	21:00	0.005	0.081	0.063	0.074	0.062	0.081	0.073	0.044	0.049	0.039	#DIV/0!	#DIV/0!	0.054	0.085	0.079	0.062
21:00	22:00	0.005	0.081	0.063	0.074	0.062	0.081	0.073	0.044	0.047	0.028	#DIV/0!	#DIV/0!	0.045	0.070	0.065	0.047
22:00	23:00	0.005	0.081	0.063	0.074	0.062	0.081	0.073	0.044	0.048	0.028	#DIV/0!	#DIV/0!	0.045	0.070	0.065	0.047
23:00	0:00	0.005	0.081	0.063	0.074	0.062	0.081	0.073	0.044	0.048	0.028	#DIV/0!	#DIV/0!	0.045	0.070	0.065	0.048
	Day	0.006	0.096	0.075	0.085	0.073	0.096	0.086	0.055	0.051	0.036	0.130	0.149	0.052	0.081	0.075	0.059

Note:

Vehicle classes

- MC-1 PC+LGV-petrol
- MC-3 PC+LGV<2,6-diesel
- MC-4 LGV2.6-3.5t-diesel
- MC-5 PLB (LPG/Diesel)
- MC-6 LGV>3.5t-diesel
- MC-7 HGV<15t-diesel
- MC-8 HGV>15t-diesel
- MC-10 Fran DD bus - diesel
- MC-11 Motorcycle -petrol
- Taxi-3 Taxi
- Taxi-4 PrLB<3,5t-diesel
- Taxi-5 PrLB>3,5t (LPG/Diesel)
- Taxi-6 Non-fran bus<6,4t-diesel
- Taxi-7 Non-fran bus<6,4-15t-diesel
- Taxi-8 Non-fran bus>15t-diesel
- Taxi-10 Fran SD bus - diesel

#DIV/0! means zero VMT

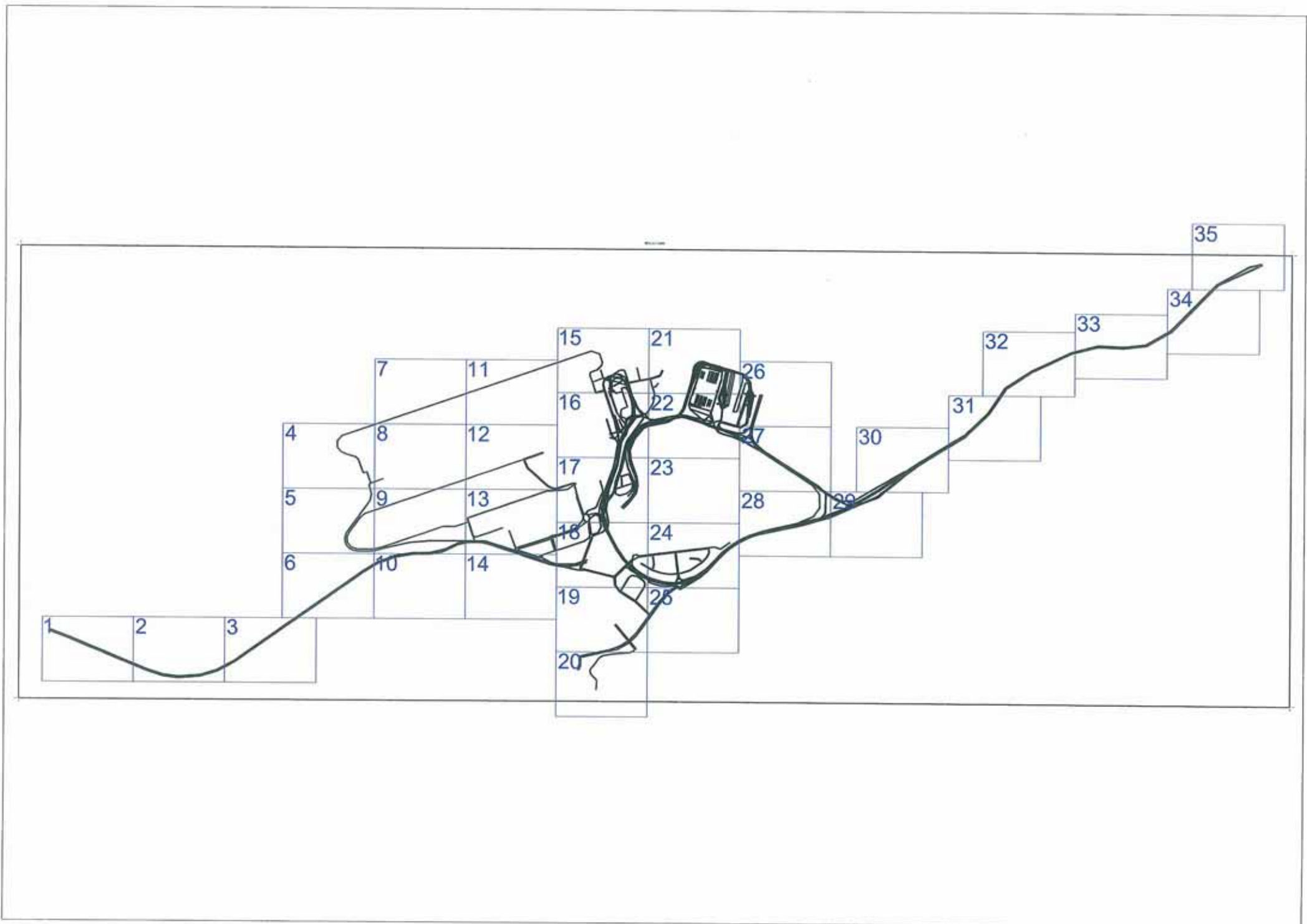

1

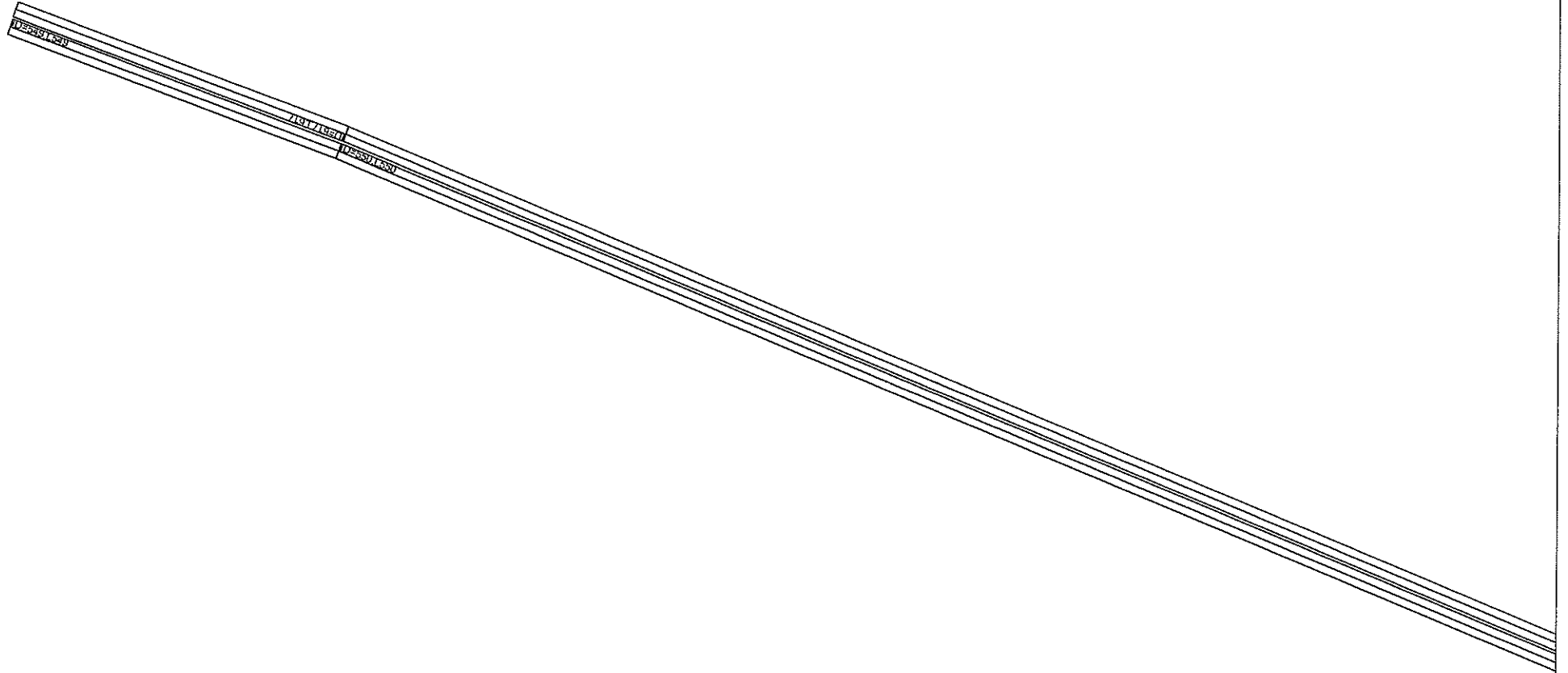

3

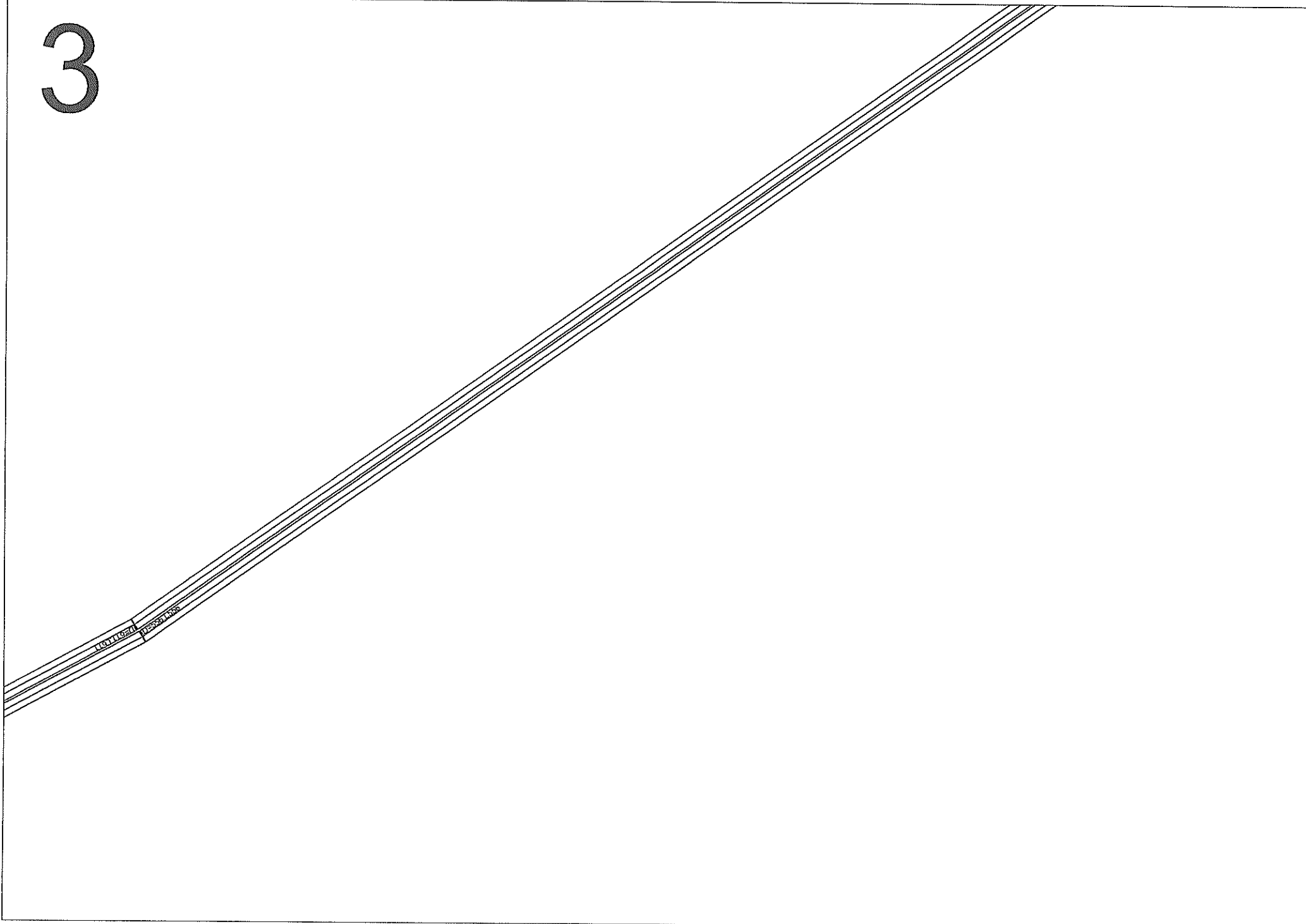

4

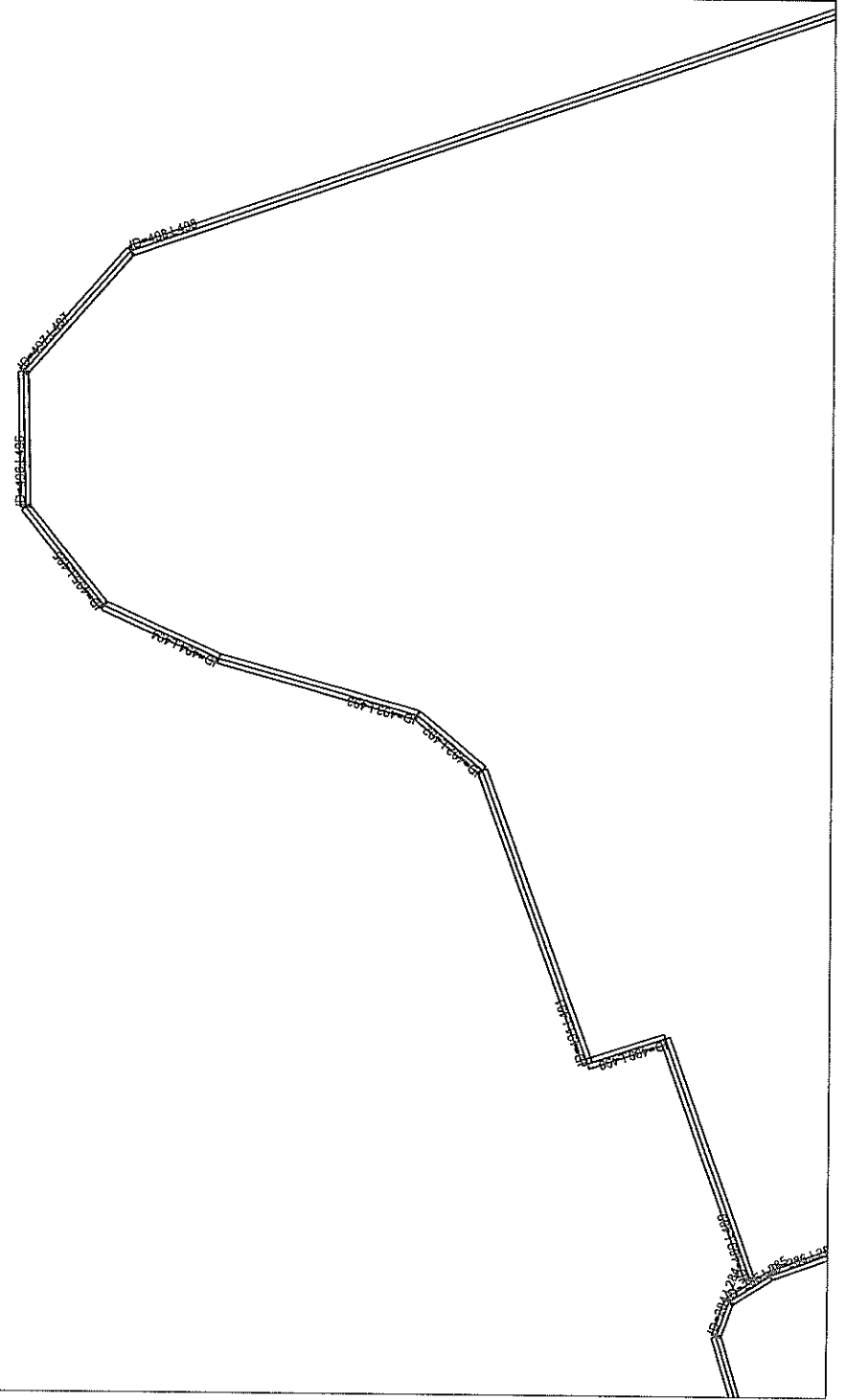

5

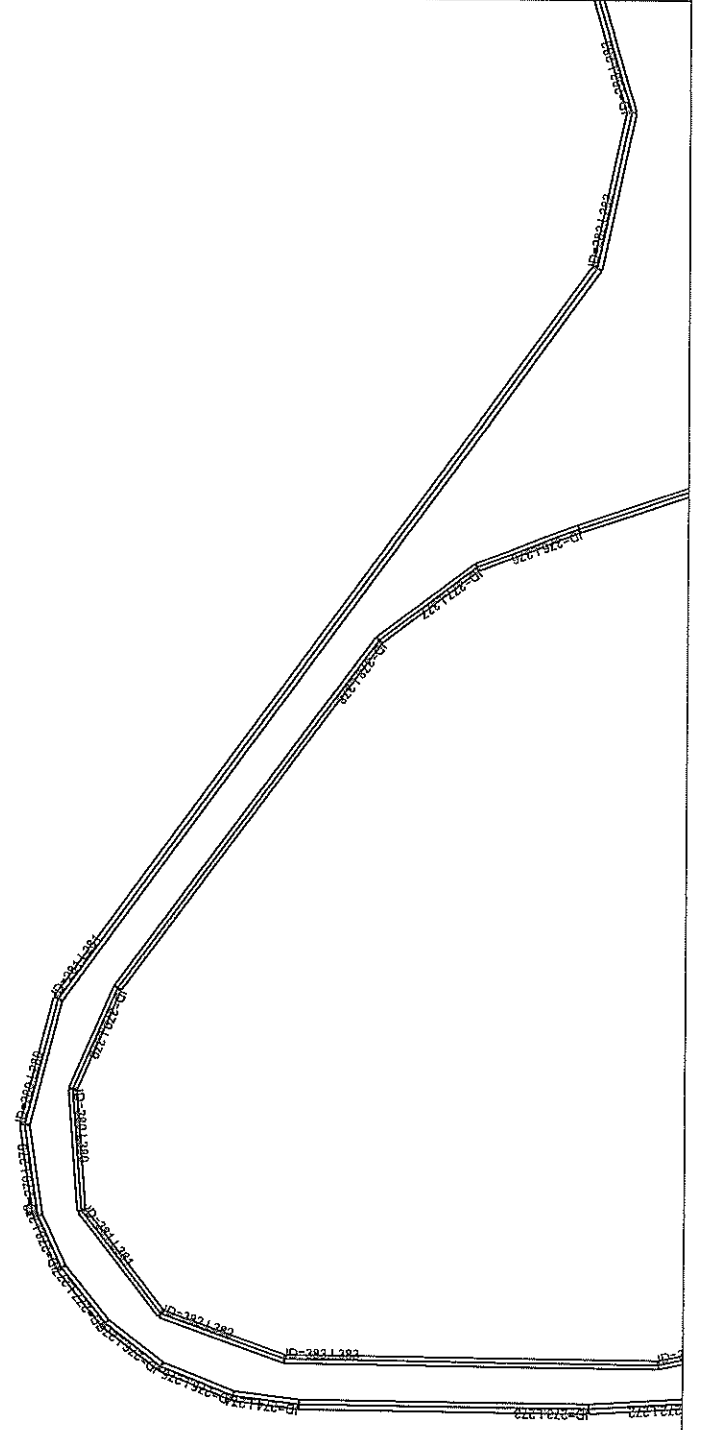

6

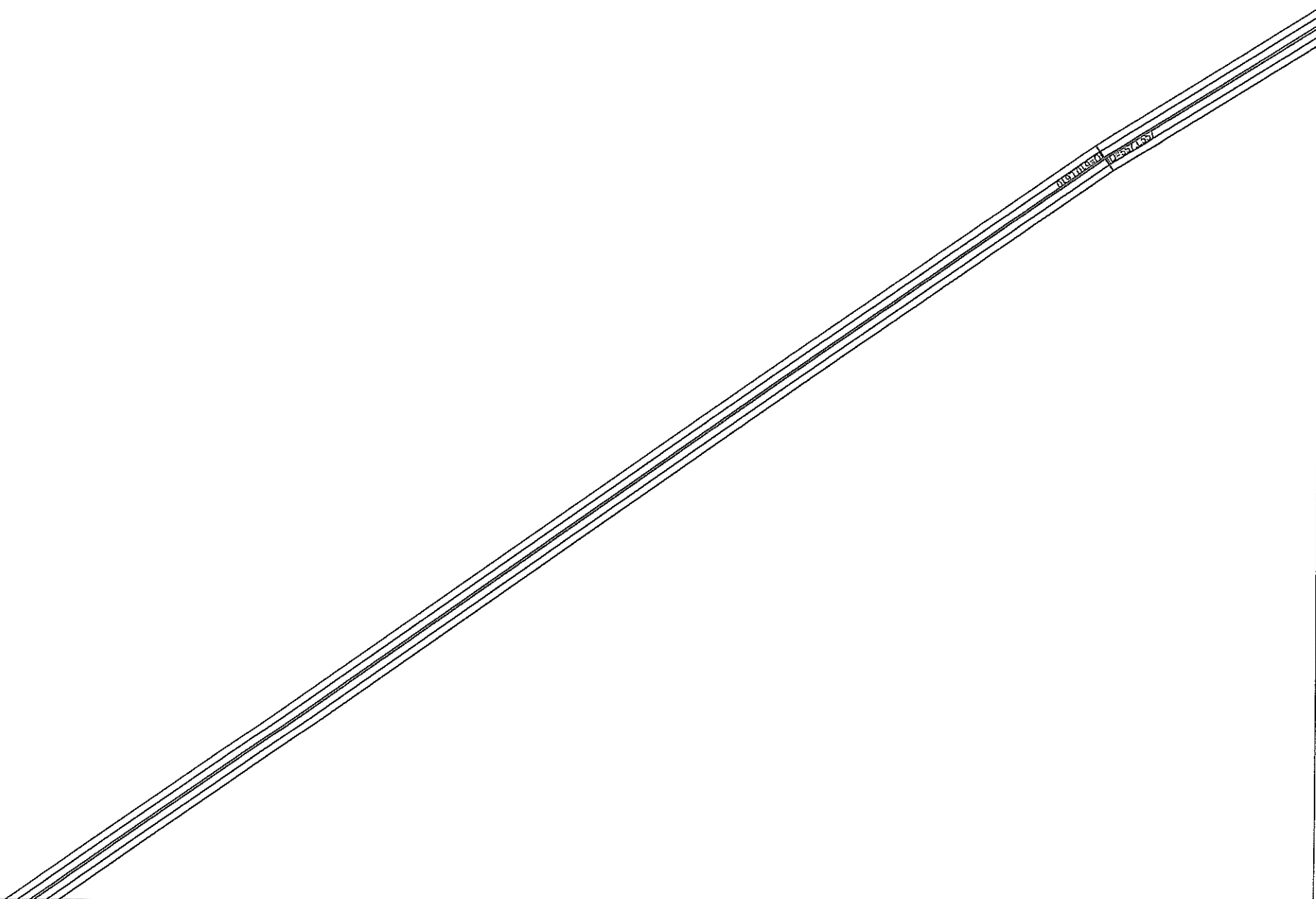

7

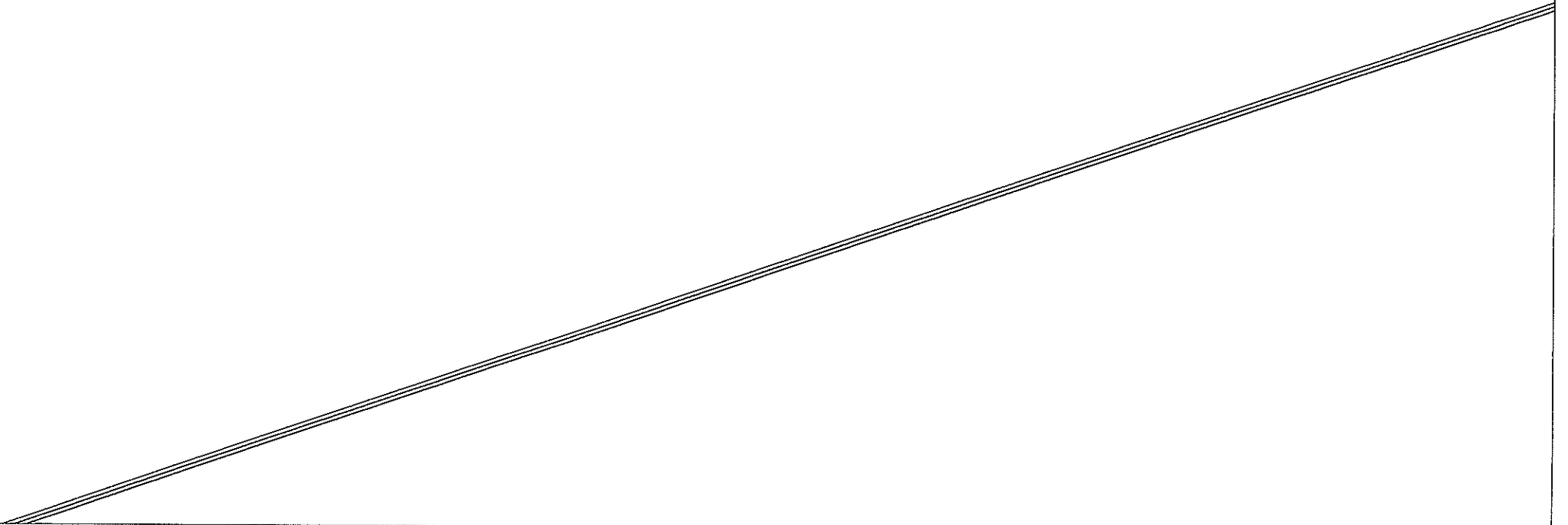

8

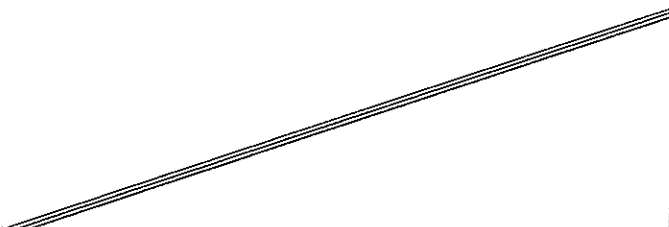
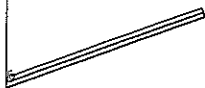

9

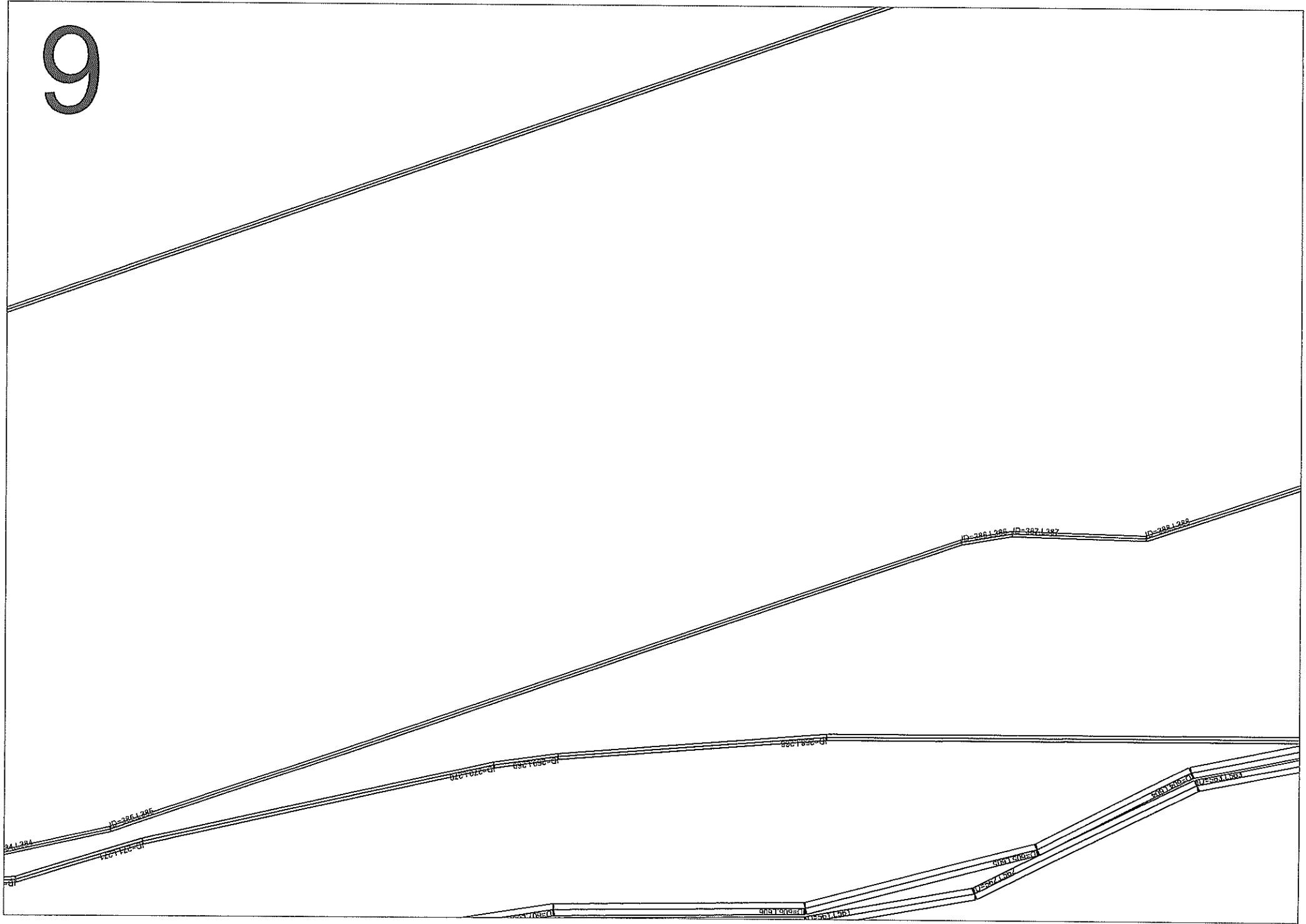

10

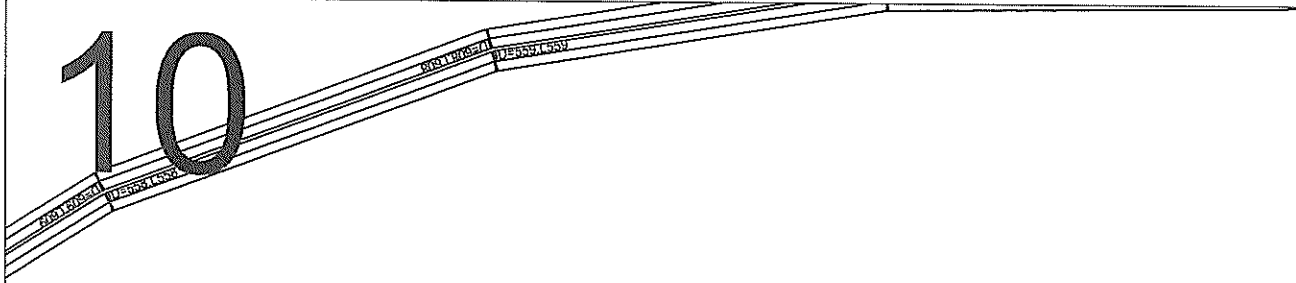

11

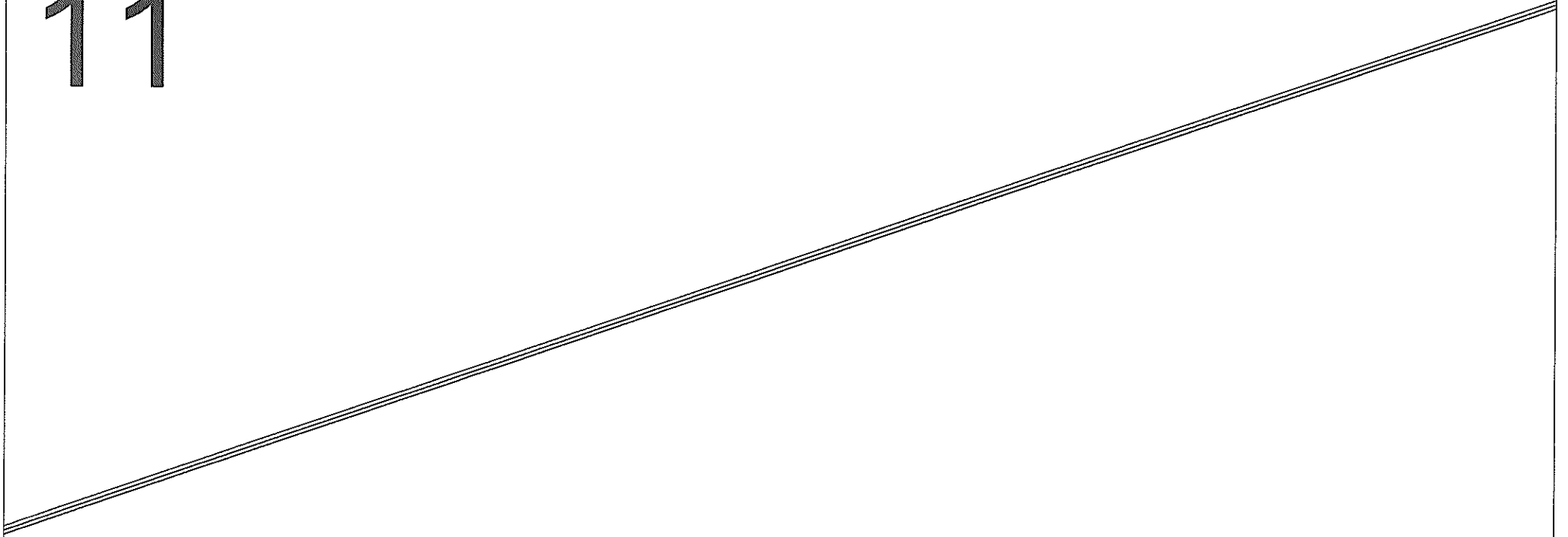

12

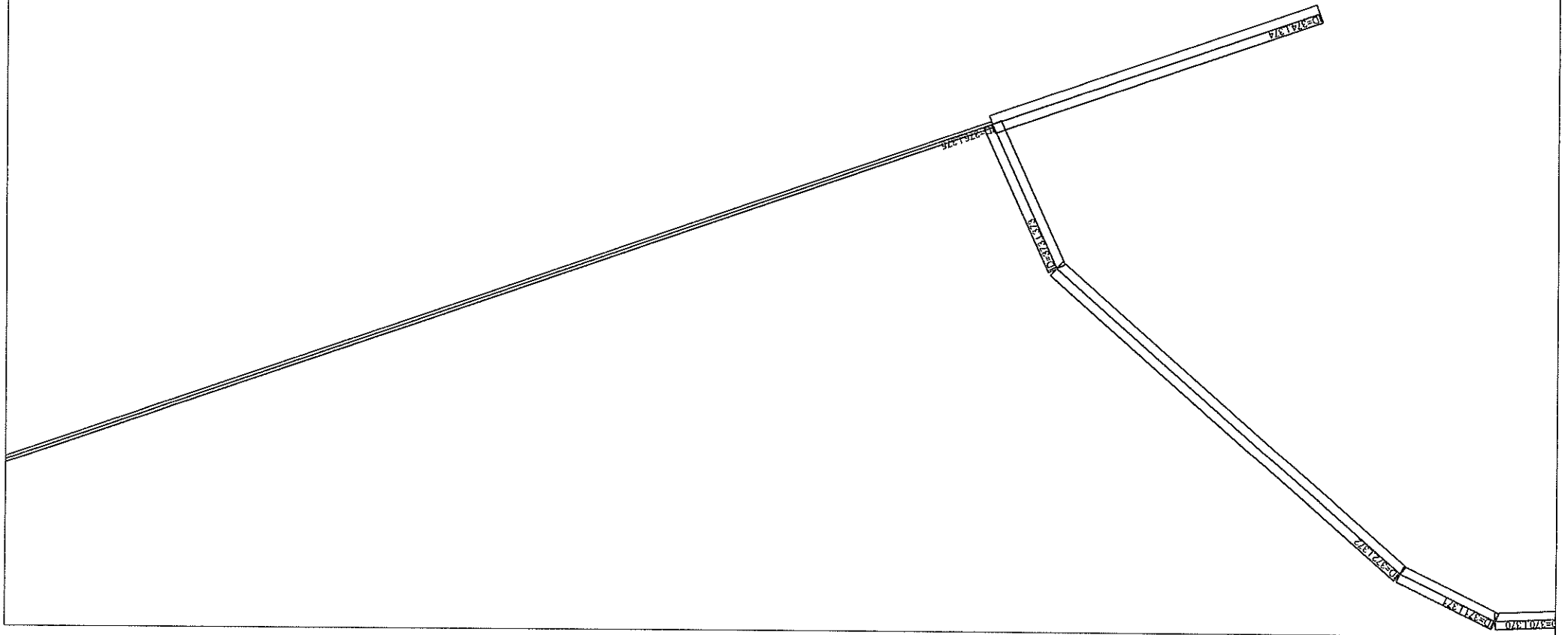

13

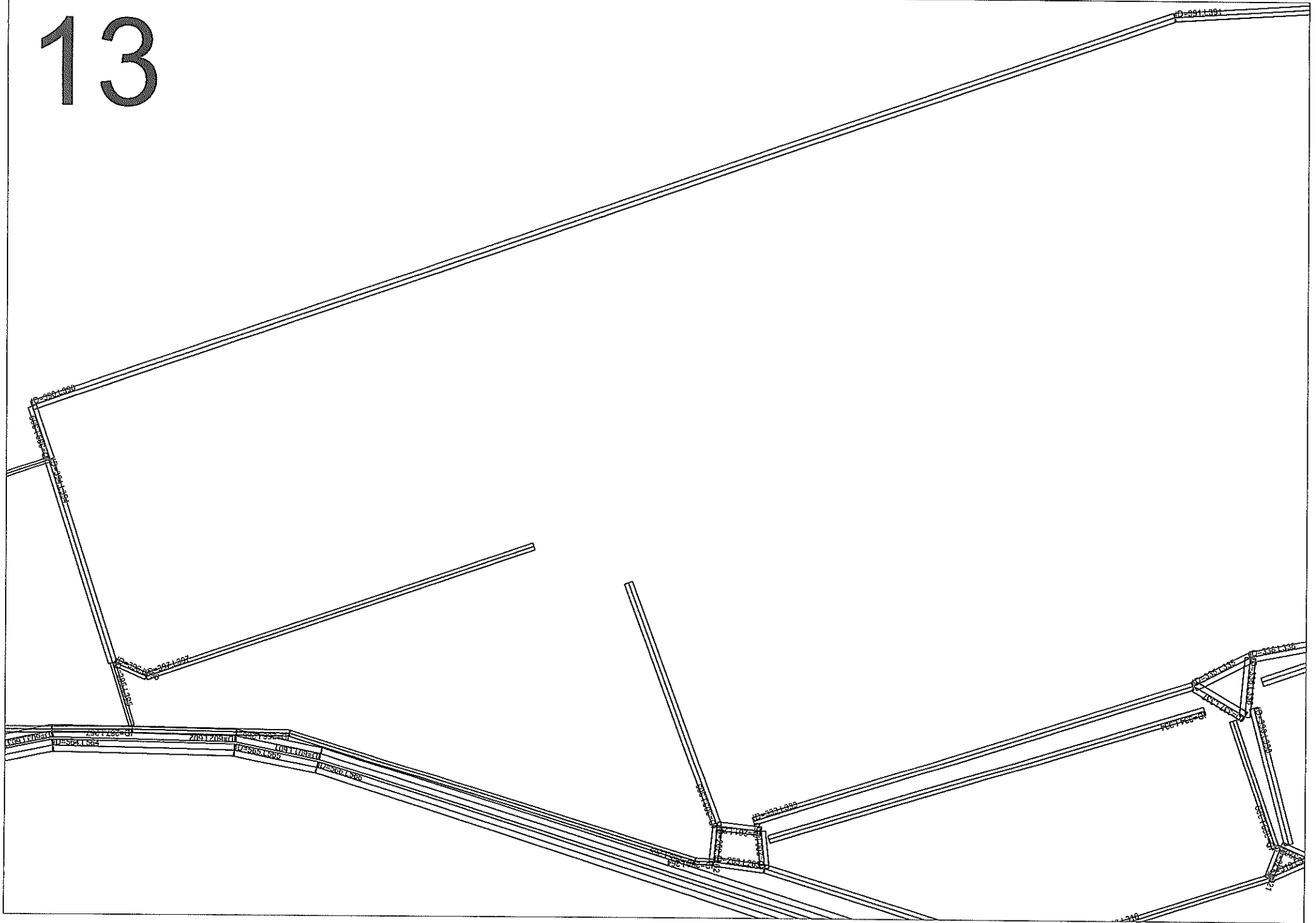

14

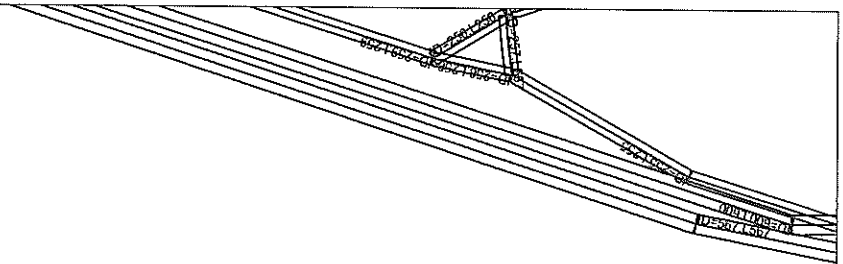

15



16

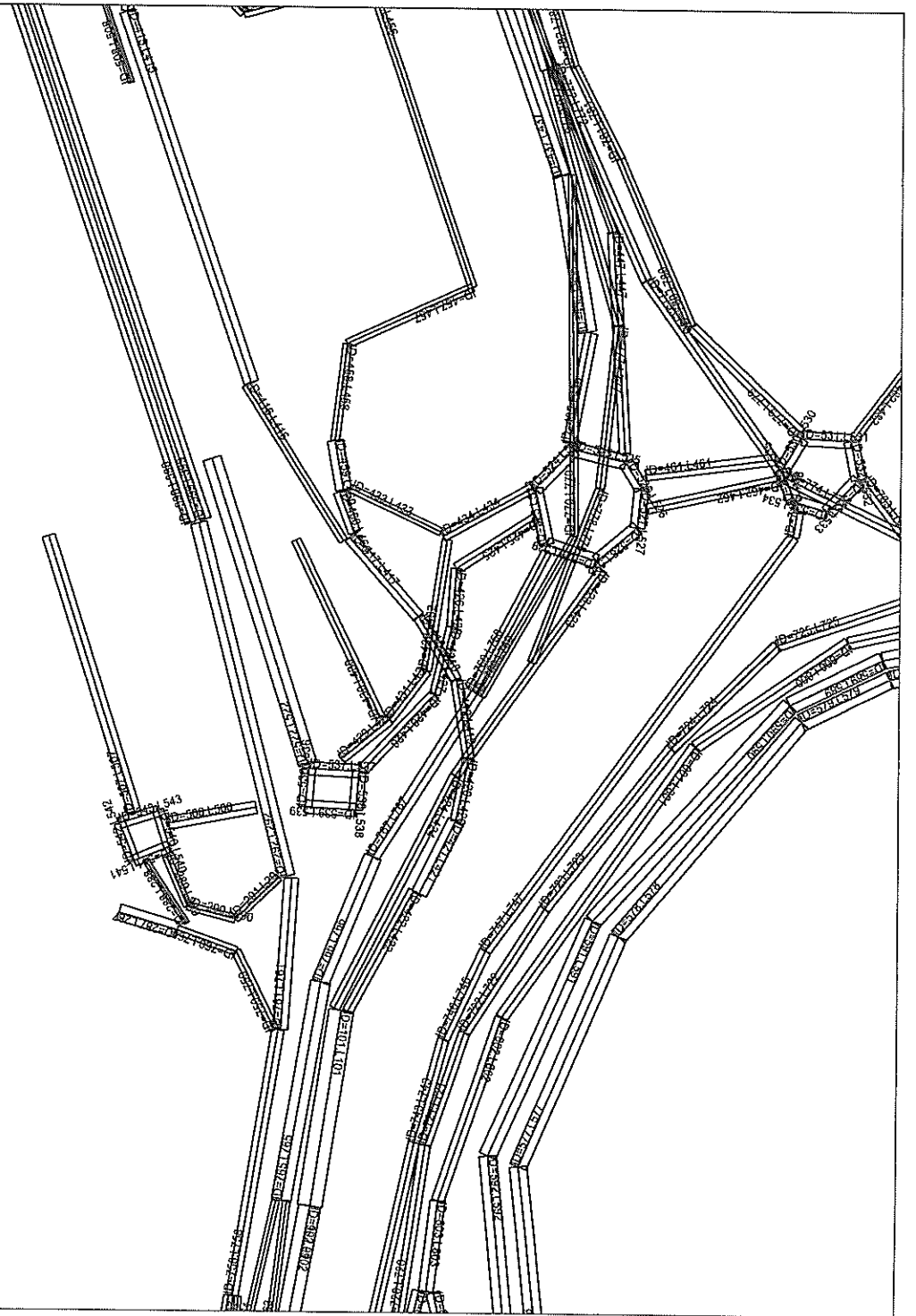

17

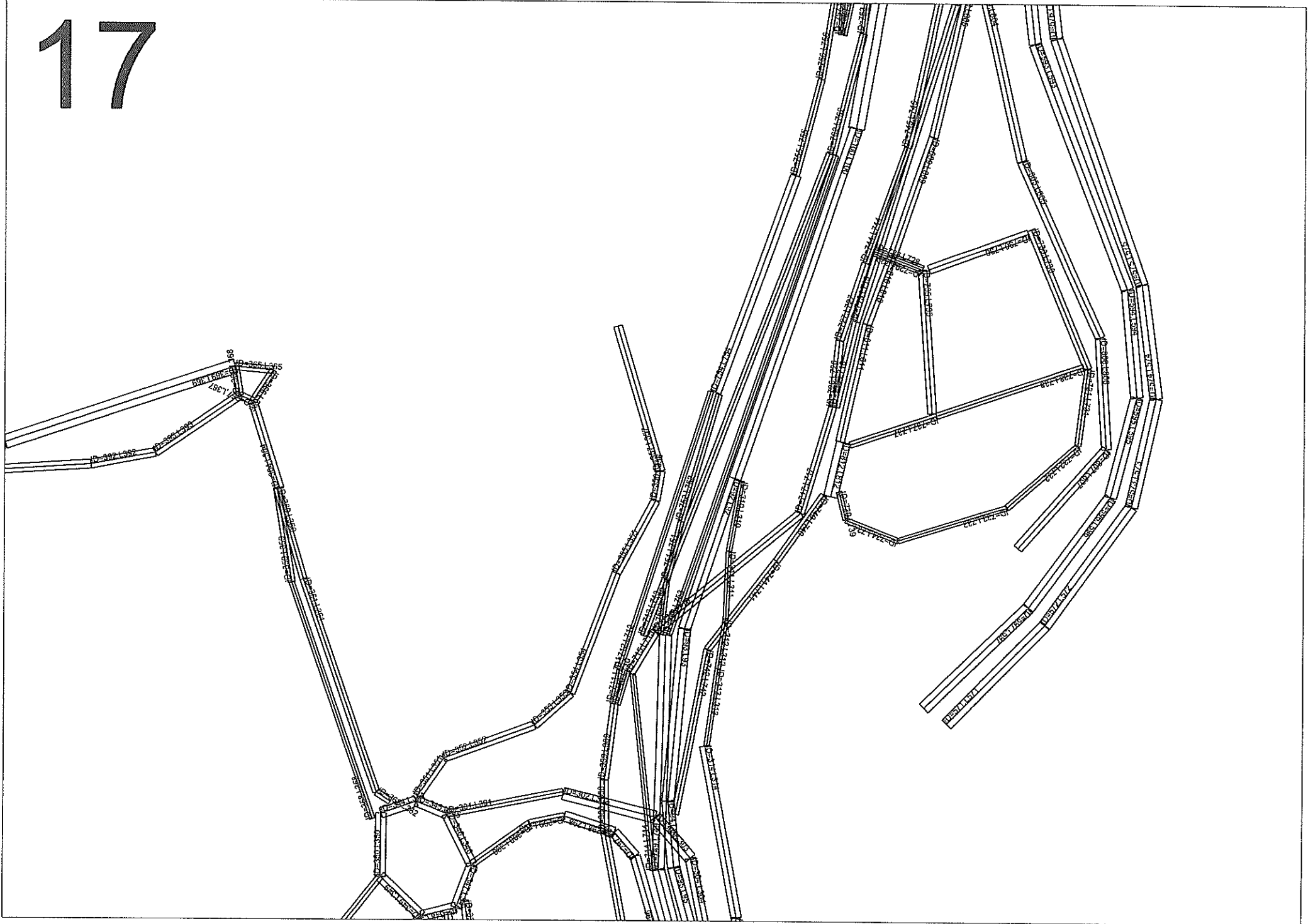

18

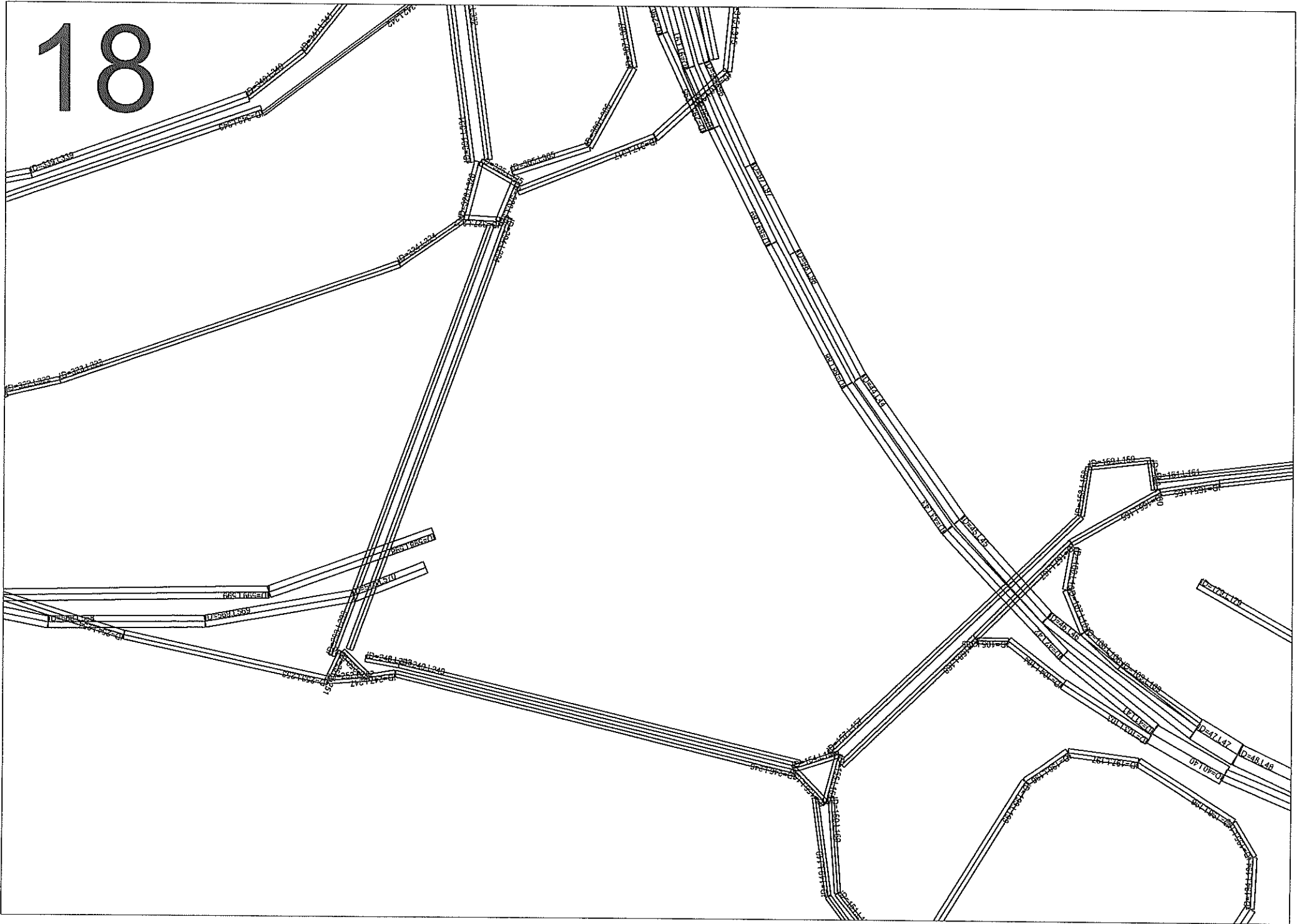

19

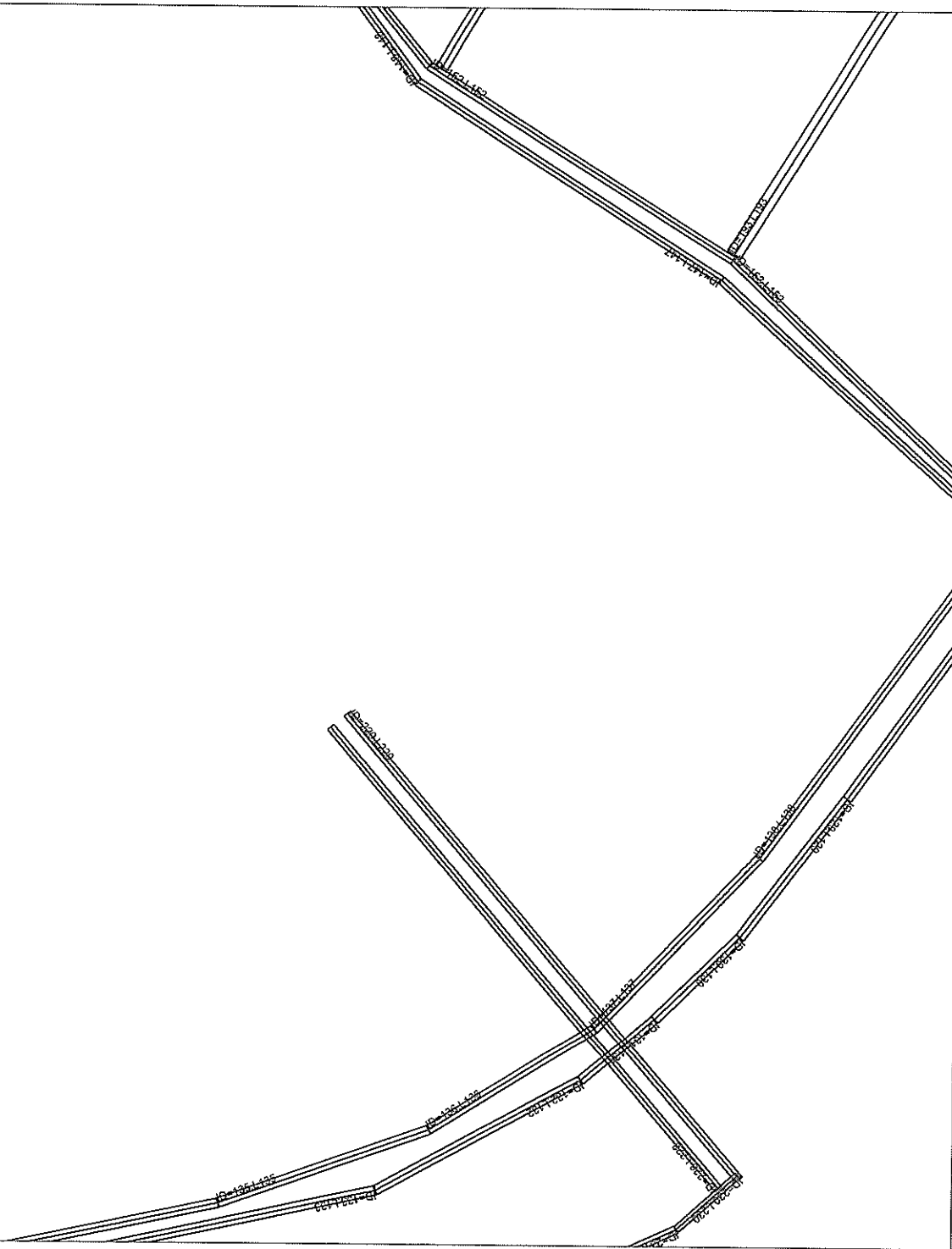

20



21

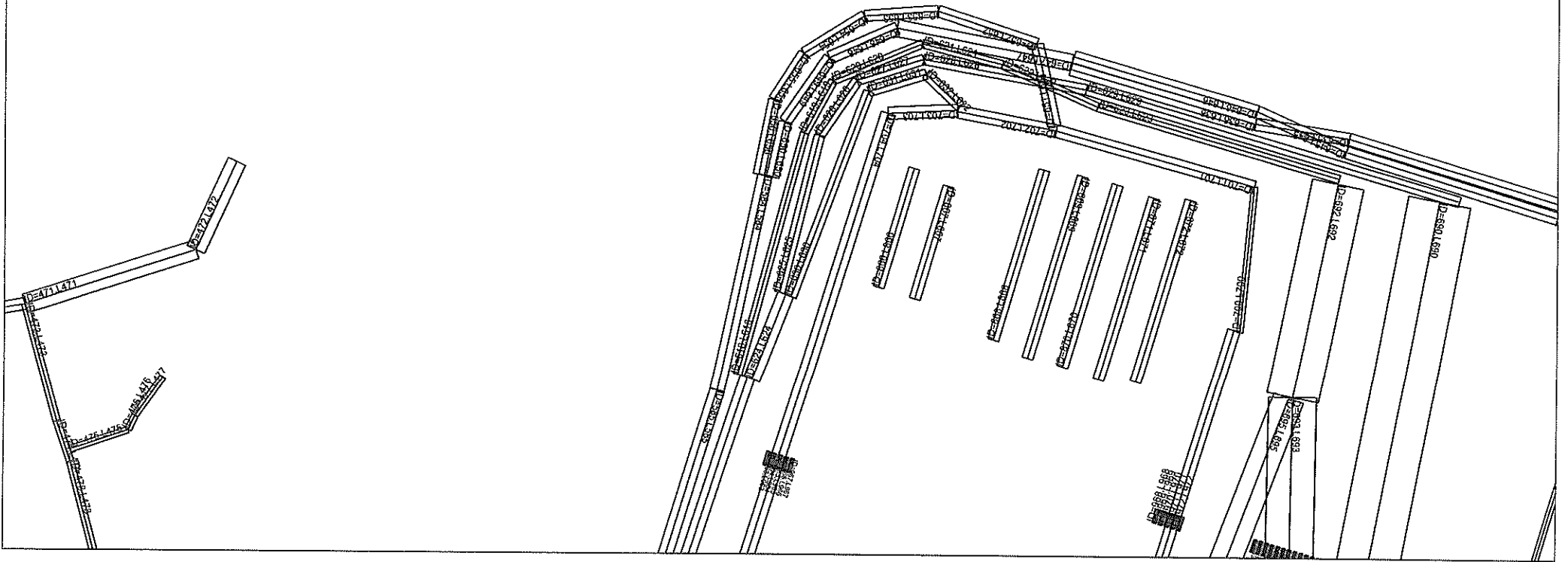

22

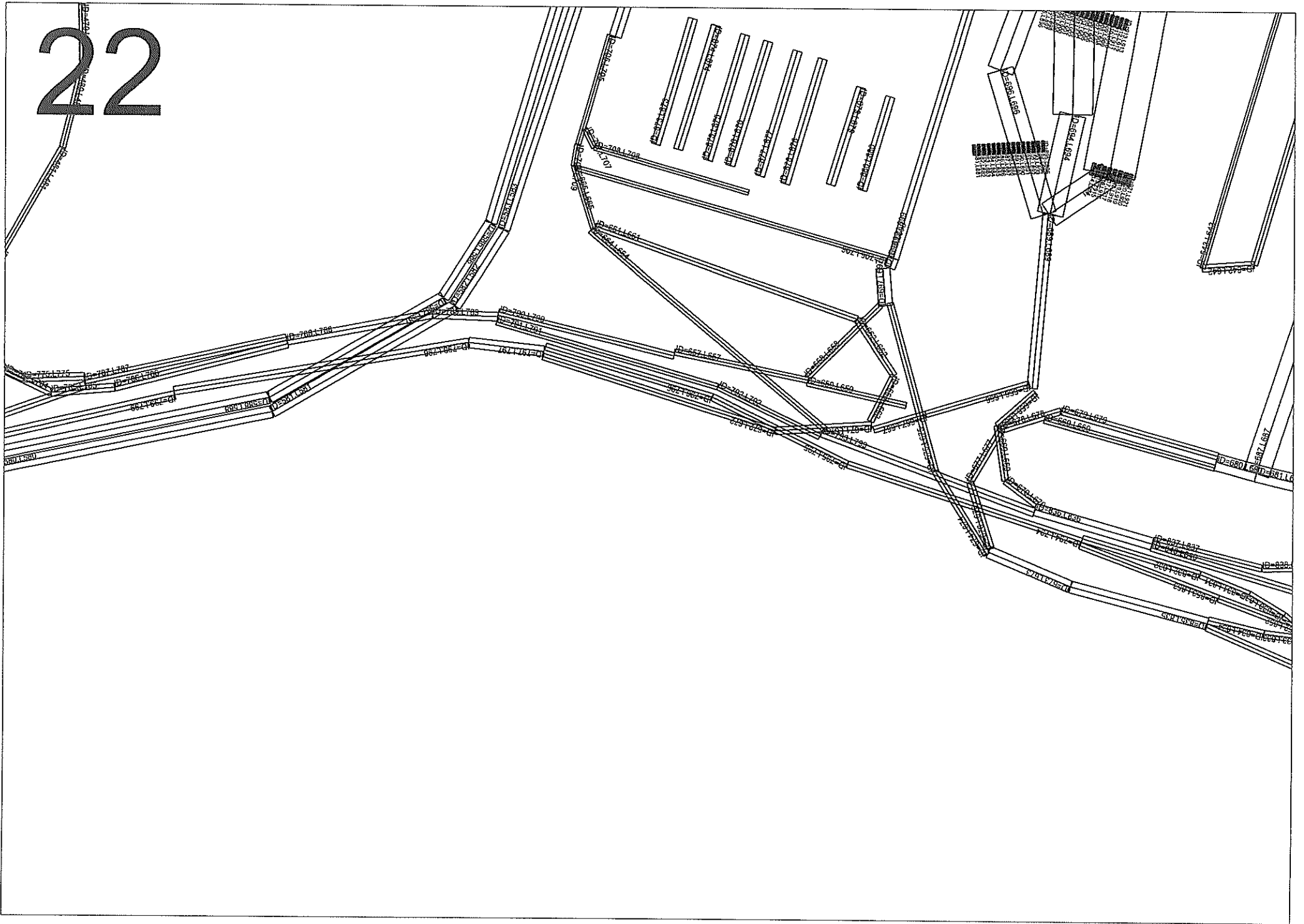

23

25

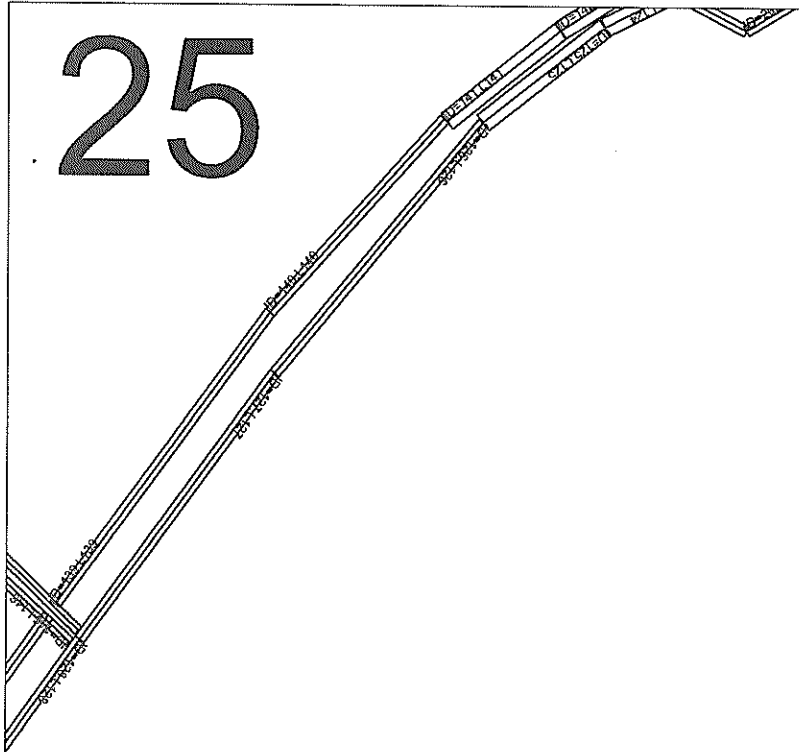

27

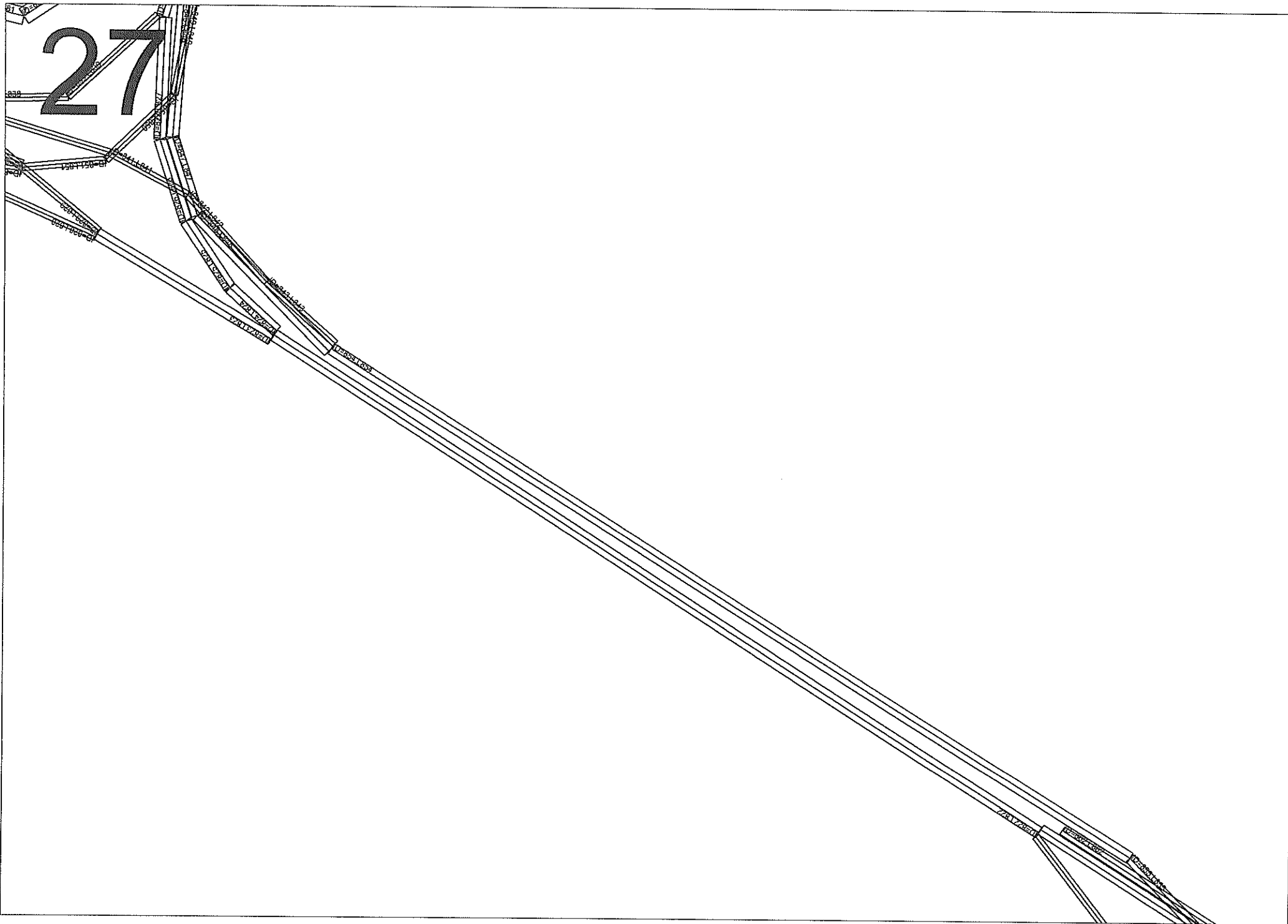

28

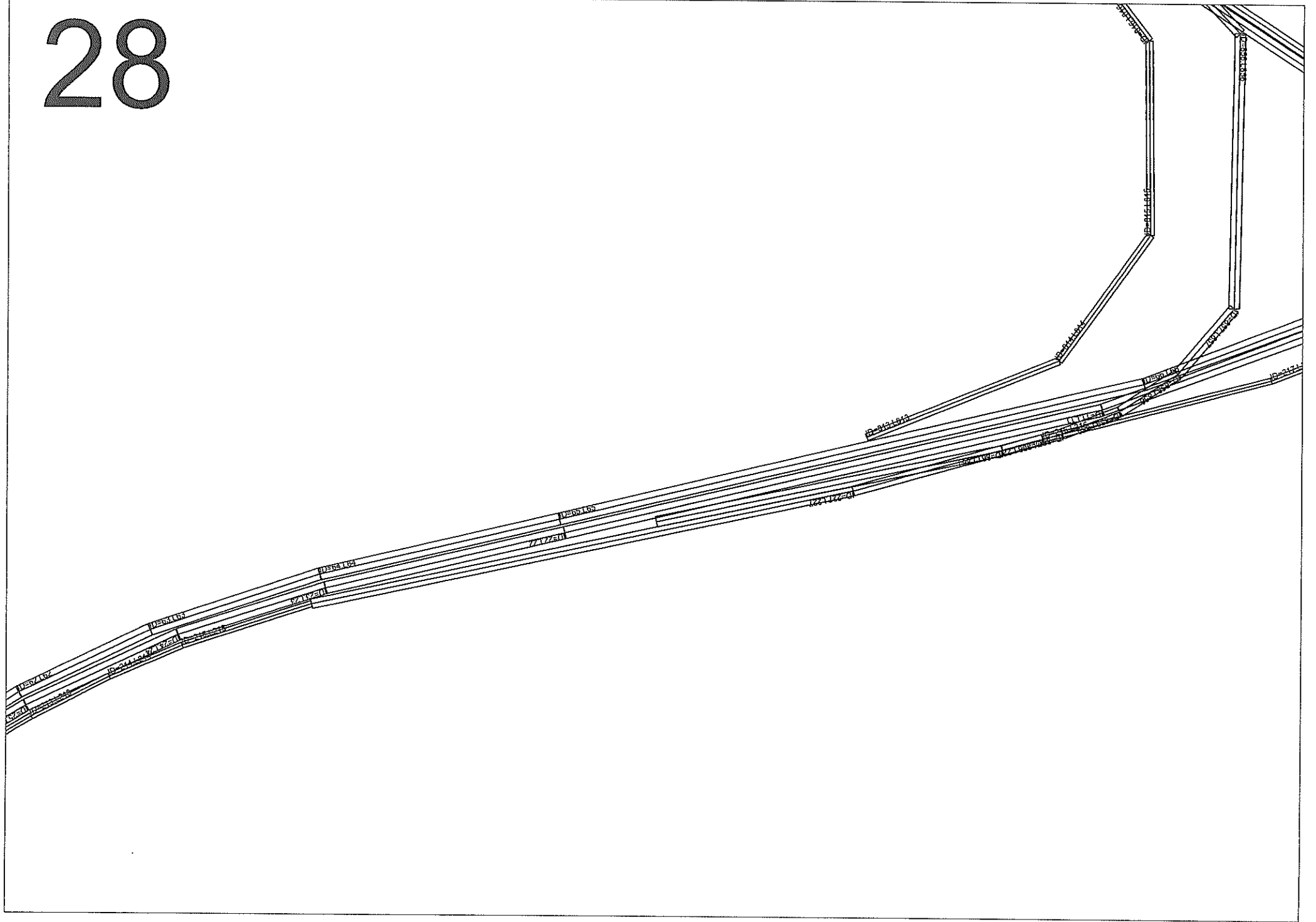

29

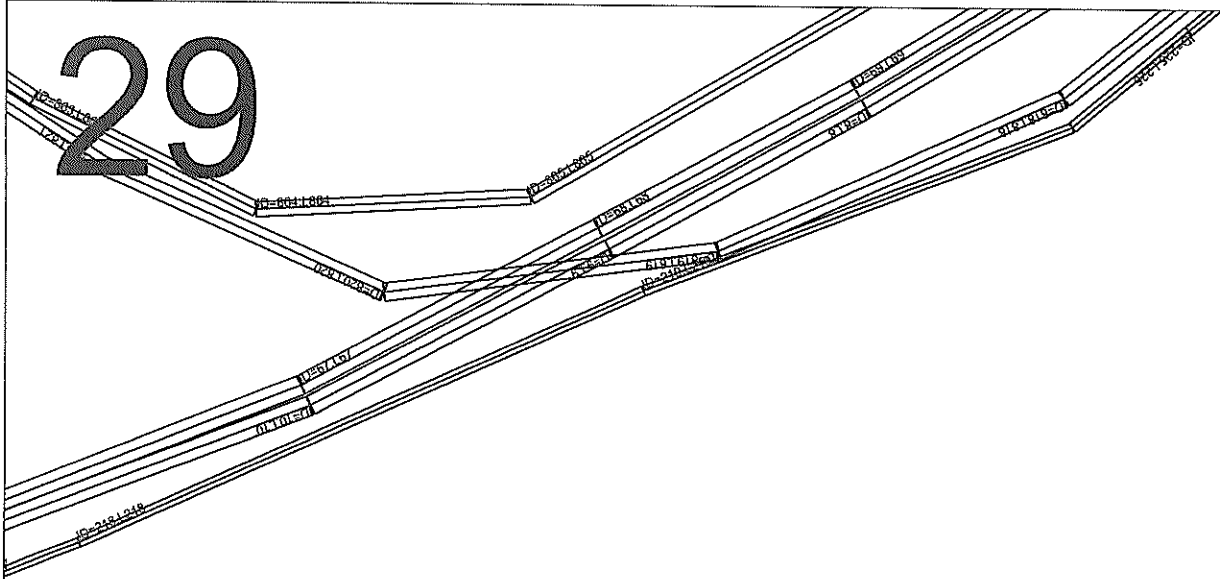

30



31

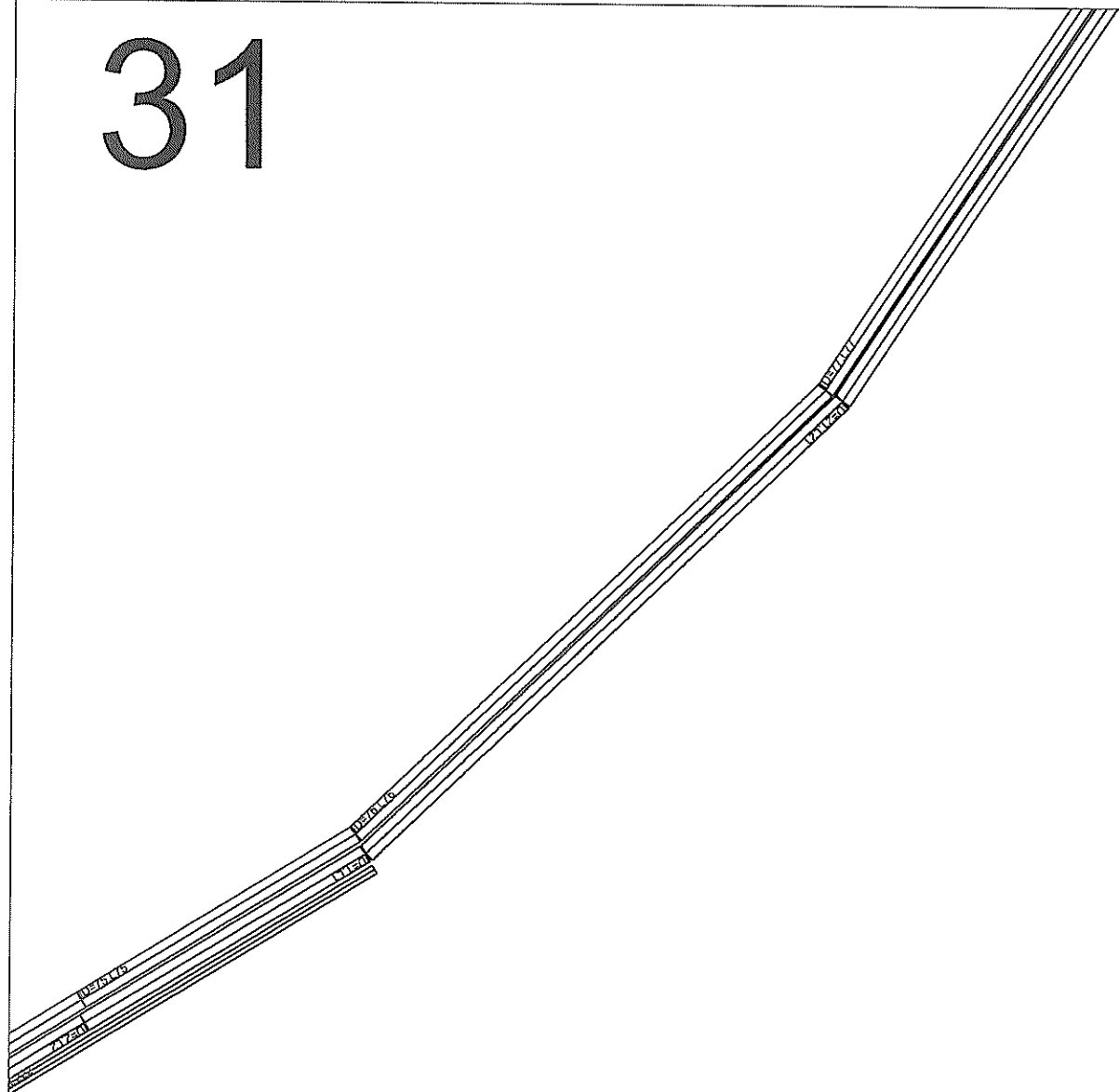

32



33

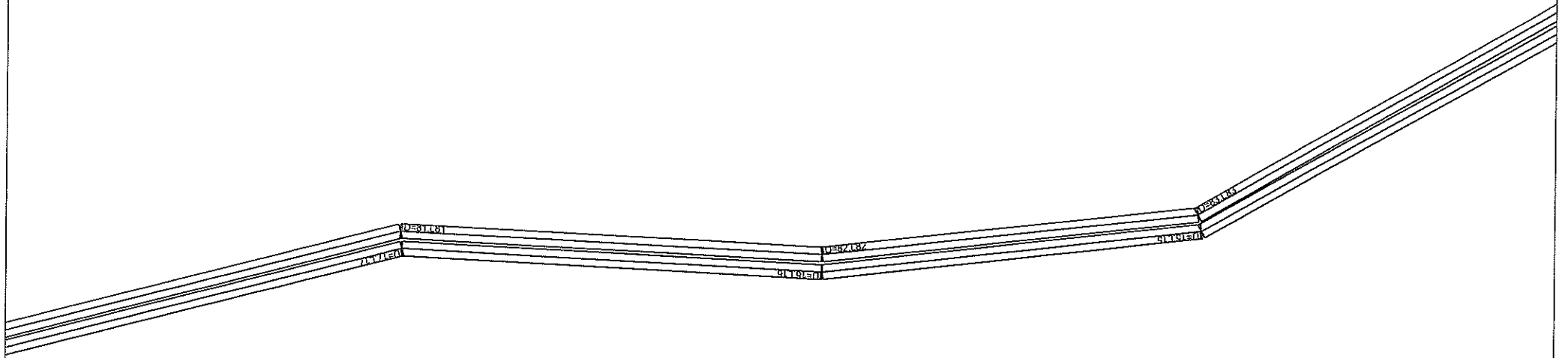

34

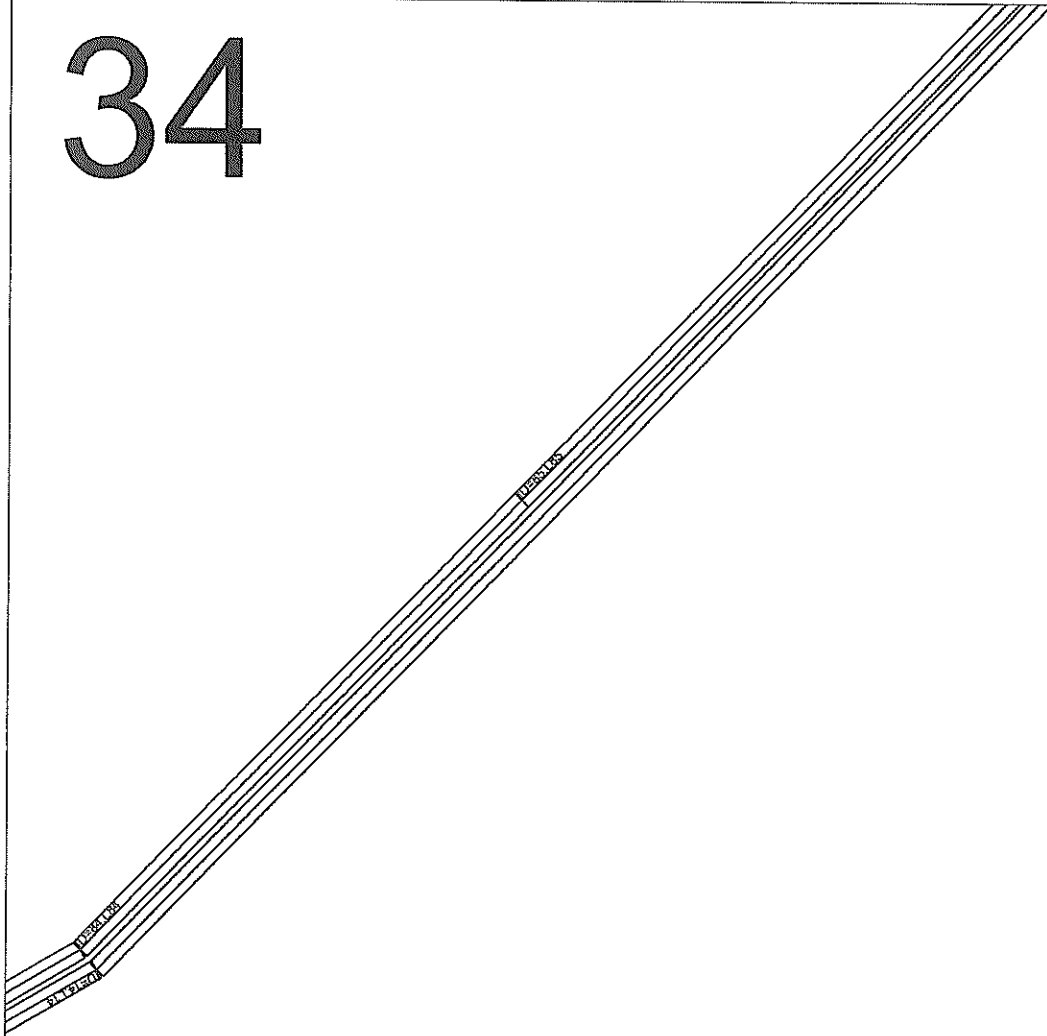

35

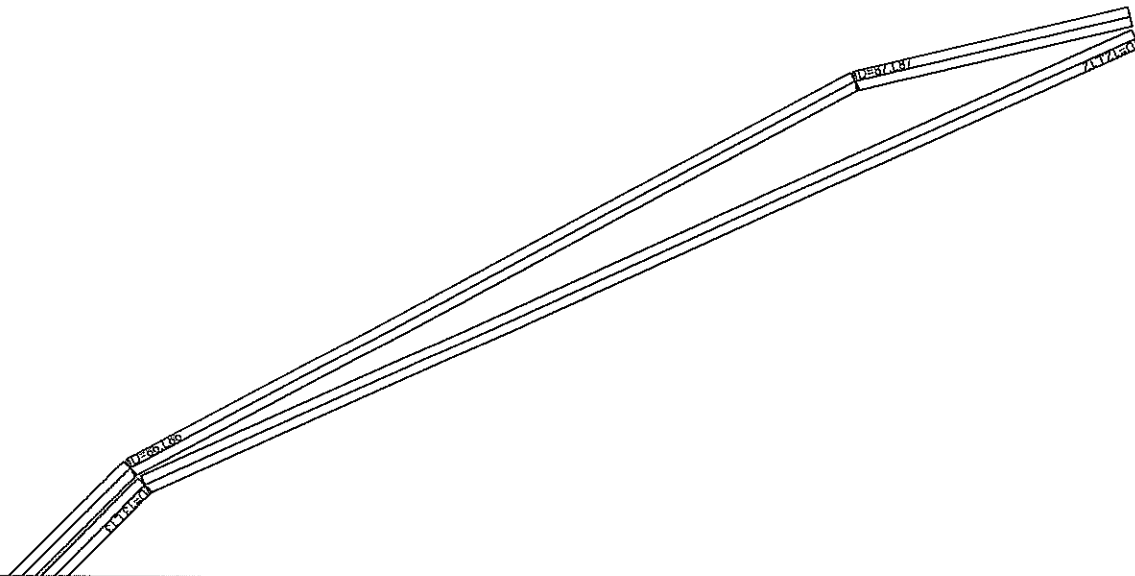

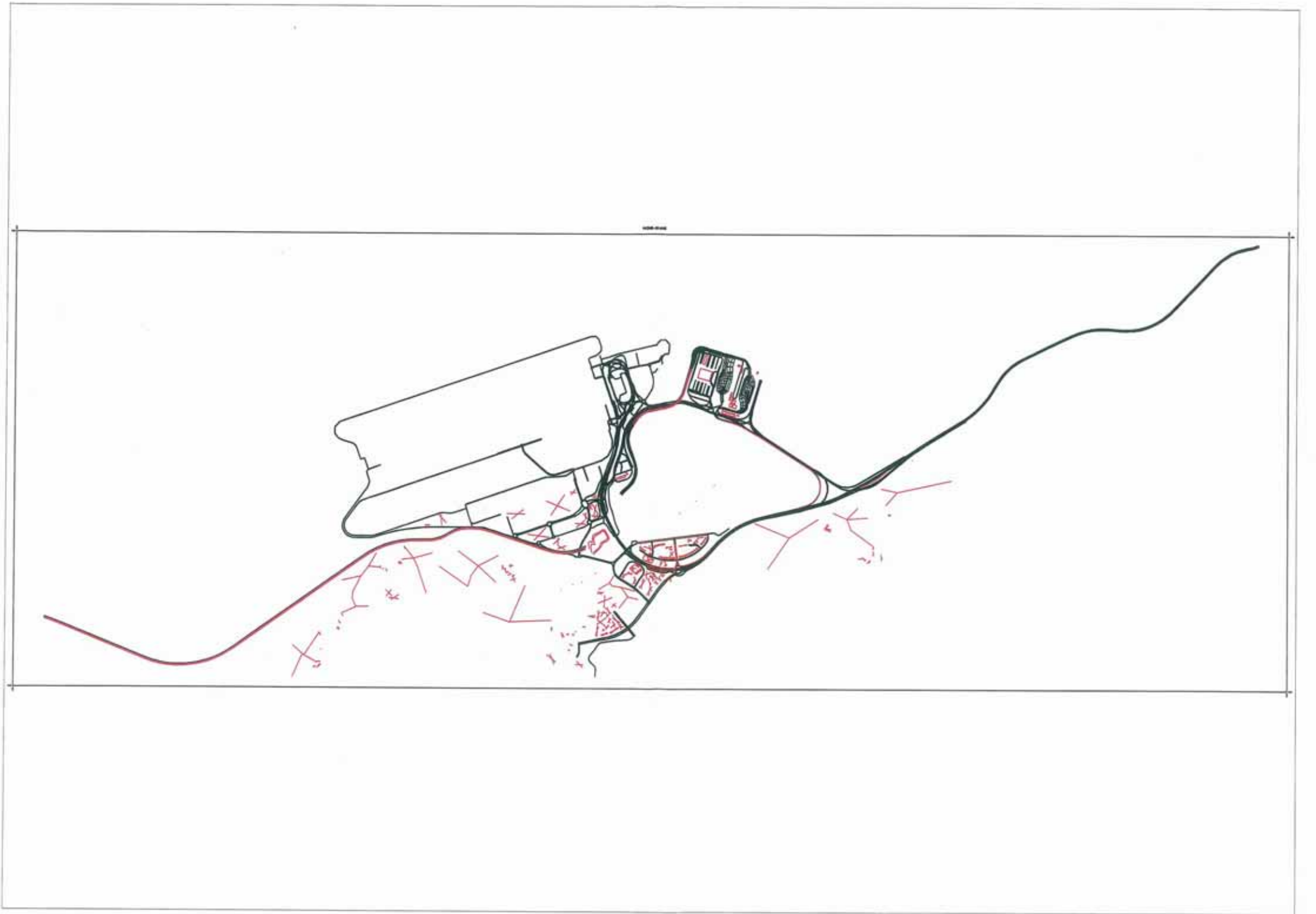

Table with columns: Row Label, Row No., Column Label, and numerical data. Columns include 'Head Line' (Hr 01-Hr 24) and 'Data' (LNK No., Column Labels, Values). Rows are grouped by 'Head Line' and include various alphanumeric labels like 'Hr 01' to 'Hr 24'.

Road Link	Link No	Road				Hr 01		Hr 02		Hr 03		Hr 04		Hr 05		Hr 06		Hr 07		Hr 08		Hr 09		Hr 11		Hr 12		Hr 13		Hr 14		Hr 16		Hr 17		Hr 18		Hr 19		Hr 20		Hr 21		Hr 22		Hr 23		Hr 24								
		Start	End	Wdth	Flow	Flow	Flow	Flow	Flow	Flow	Flow	Flow	Flow	Flow	Flow	Flow	Flow	Flow	Flow	Flow	Flow	Flow	Flow	Flow	Flow	Flow	Flow	Flow	Flow	Flow	Flow	Flow	Flow	Flow	Flow	Flow	Flow	Flow	Flow	Flow	Flow	Flow	Flow	Flow	Flow	Flow	Flow	Flow	Flow							
TMCLEC Road No1 Flyover-1	L710	SR13252-SR13263	SR13263-SR13273	6	28	5.602	43.527	30.0	5.655	21.8	5.892	24.0	5.850	50.0	5.926	15.0	6.021	25.0	6.116	29.0	6.217	33.0	6.324	37.0	6.438	41.0	6.558	45.0	6.683	49.0	6.814	53.0	6.950	57.0	7.092	61.0	7.239	65.0	7.392	69.0	7.550	73.0	7.713	77.0	7.881	81.0	8.054	85.0	8.232	89.0	8.415	93.0	8.603	97.0	8.796	101.0
TMCLEC Road No2 Flyover-1	L711	SR13273-SR13283	SR13283-SR13293	6	28	5.602	43.527	30.0	5.655	21.8	5.892	24.0	5.850	50.0	5.926	15.0	6.021	25.0	6.116	29.0	6.217	33.0	6.324	37.0	6.438	41.0	6.558	45.0	6.683	49.0	6.814	53.0	6.950	57.0	7.092	61.0	7.239	65.0	7.392	69.0	7.550	73.0	7.713	77.0	7.881	81.0	8.054	85.0	8.232	89.0	8.415	93.0	8.603	97.0	8.796	101.0
TMCLEC Road No3 Flyover-1	L712	SR13293-SR13303	SR13303-SR13313	6	28	5.602	43.527	30.0	5.655	21.8	5.892	24.0	5.850	50.0	5.926	15.0	6.021	25.0	6.116	29.0	6.217	33.0	6.324	37.0	6.438	41.0	6.558	45.0	6.683	49.0	6.814	53.0	6.950	57.0	7.092	61.0	7.239	65.0	7.392	69.0	7.550	73.0	7.713	77.0	7.881	81.0	8.054	85.0	8.232	89.0	8.415	93.0	8.603	97.0	8.796	101.0

Road Link	Line No.	Start	End	Hr 01		Hr 02		Hr 03		Hr 04		Hr 05		Hr 06		Hr 07		Hr 08		Hr 09		Hr 10		Hr 11		Hr 12		Hr 13		Hr 14		Hr 15		Hr 16		Hr 17		Hr 18		Hr 19		Hr 20		Hr 21		Hr 22		Hr 23		Hr 24				
				Flow	Flow	Flow	Flow	Flow	Flow	Flow	Flow	Flow	Flow	Flow	Flow	Flow	Flow	Flow	Flow	Flow	Flow	Flow	Flow	Flow	Flow	Flow	Flow	Flow	Flow	Flow	Flow	Flow	Flow	Flow	Flow	Flow	Flow	Flow	Flow	Flow	Flow	Flow	Flow	Flow	Flow	Flow	Flow	Flow	Flow	Flow	Flow			
TMC/EC Sp Road 017	L603	183523	183524	183525	183526	183527	183528	183529	183530	183531	183532	183533	183534	183535	183536	183537	183538	183539	183540	183541	183542	183543	183544	183545	183546	183547	183548	183549	183550	183551	183552	183553	183554	183555	183556	183557	183558	183559	183560	183561	183562	183563	183564	183565	183566	183567	183568	183569	183570	183571	183572	183573	183574	
	L604	183575	183576	183577	183578	183579	183580	183581	183582	183583	183584	183585	183586	183587	183588	183589	183590	183591	183592	183593	183594	183595	183596	183597	183598	183599	183600	183601	183602	183603	183604	183605	183606	183607	183608	183609	183610	183611	183612	183613	183614	183615	183616	183617	183618	183619	183620	183621	183622	183623	183624	183625	183626	183627

