

NOTES :

Guillotine Failure of Aboveground Pipe (Liquid-Inlet Pipework, Flexible Hose to Vessel)

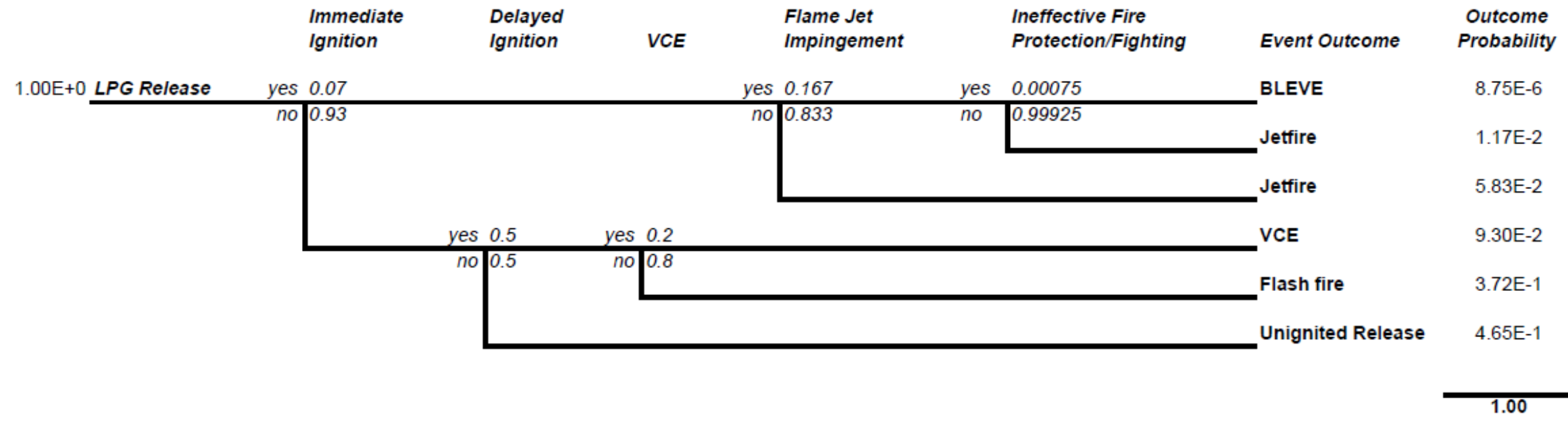

Leak of Aboveground Pipe (Liquid-Inlet Pipework, Flexible Hose to Vessel)

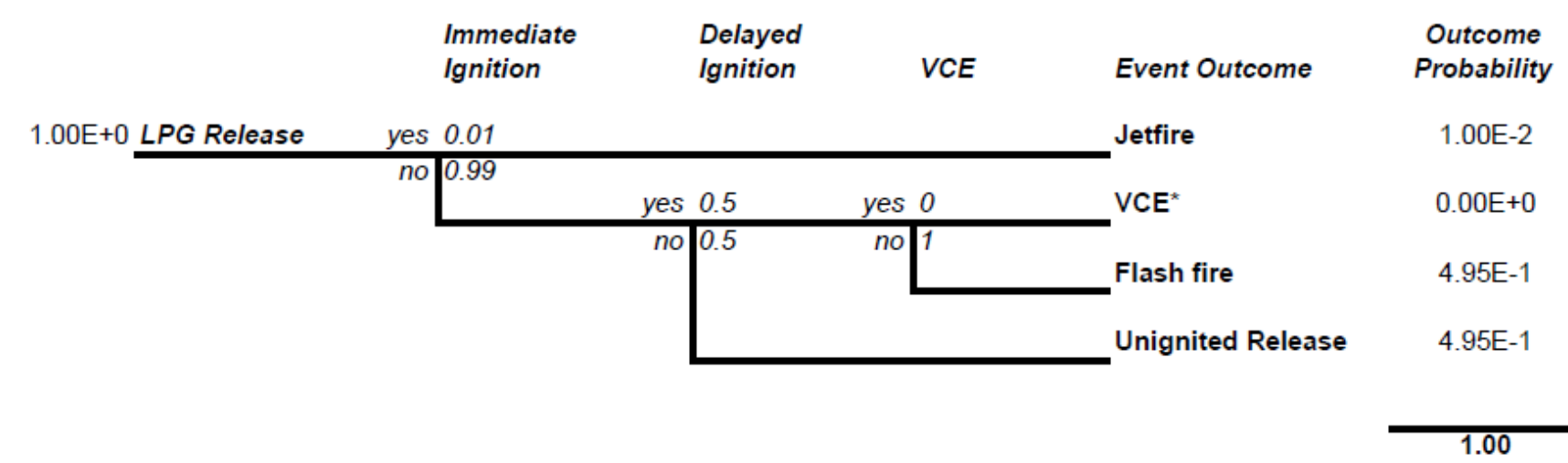

* VCE is not considered for a small release.

Consultant



AEC

Allied Environmental Consultants Limited
ACOUSTICIANS & ENVIRONMENTAL ENGINEERS

Project No. : 1158

File Name :

Project :
Chai Wan Government Complex and Vehicle Depot

Drawing Title :
Event Trees for Guillotine Failure and Leak of Aboveground Pipe of Petrol Cum LPG Station

Drawing No : Figure 10.15 Revision : 2

Scale : NTS Date : May 2015

DO NOT SCALE OFF DRAWING. THIS DRAWING IS NOT FOR CONSTRUCTION PURPOSES UNLESS EXPRESSLY STATED. ALL RIGHTS RESERVED AND REPRODUCTION IN ANY FORM MUST BE APPROVED BY ALLIED ENVIRONMENTAL CONSULTANTS LIMITED.