

NOTES :

**Cold Catastrophic Failure of LPG Cylinder (Sinopec HK Oil Terminal Chai Wan)**

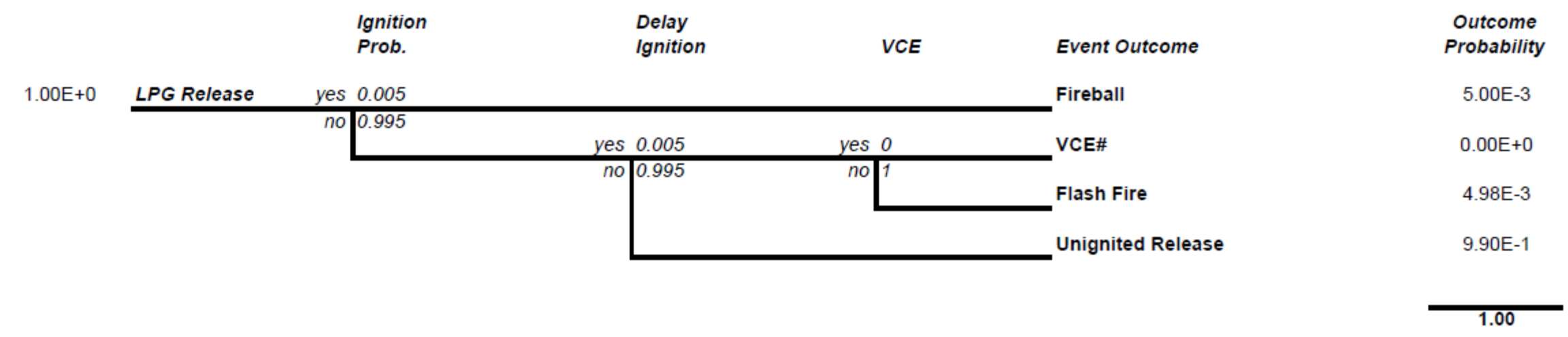

# VCE is not considered for a small release.

**Cold Partial Failure of LPG Cylinder (Sinopec HK Oil Terminal Chai Wan)**

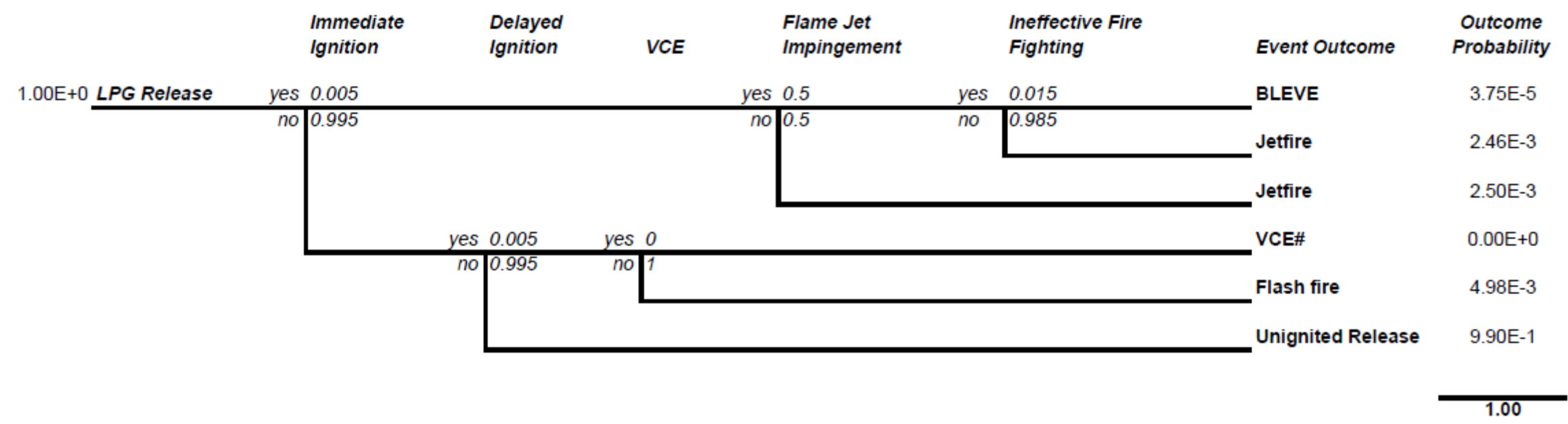

# VCE is not considered for a small release.

Consultant



**AEC**

Allied Environmental Consultants Limited  
ACOUSTICIANS & ENVIRONMENTAL ENGINEERS

Project No. : 1158

File Name :

Project :  
Chai Wan Government Complex and Vehicle Depot

Drawing Title :  
Event Trees for Catastrophic and Partial Failure of LPG Cylinder (Sinopec HK Oil Terminal)

Drawing No : Figure 10.9      Revision : 2

Scale : NTS      Date : May 2015

DO NOT SCALE OFF DRAWING. THIS DRAWING IS NOT FOR CONSTRUCTION PURPOSES UNLESS EXPRESSLY STATED. ALL RIGHTS RESERVED AND REPRODUCTION IN ANY FORM MUST BE APPROVED BY ALLIED ENVIRONMENTAL CONSULTANTS LIMITED.