

ISO A1 594mm x 841mm
 Approved:
 Checked:
 Designer:
 Project Management Initials:
 816450 N
 816440 N
 20180715
 P:\PROJECTS\60494885\DRAWING\REPORT\EA\EA_408.dgn

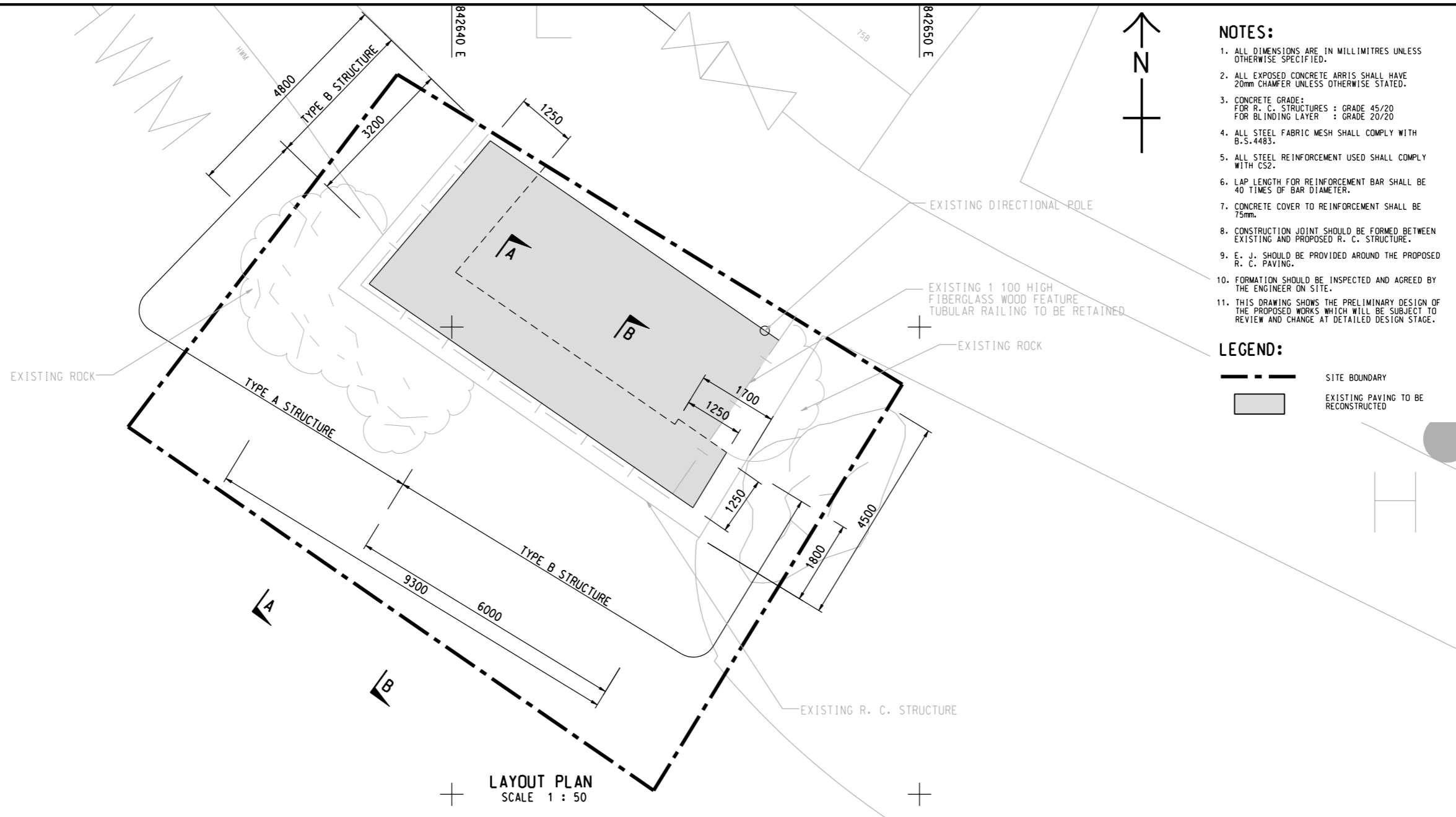

- NOTES:**
1. ALL DIMENSIONS ARE IN MILLIMETRES UNLESS OTHERWISE SPECIFIED.
 2. ALL EXPOSED CONCRETE ARRIS SHALL HAVE 20mm CHAMFER UNLESS OTHERWISE STATED.
 3. CONCRETE GRADE:
FOR R. C. STRUCTURES : GRADE 45/20
FOR BLINDING LAYER : GRADE 20/20
 4. ALL STEEL FABRIC MESH SHALL COMPLY WITH B.S.4483.
 5. ALL STEEL REINFORCEMENT USED SHALL COMPLY WITH CS2.
 6. LAP LENGTH FOR REINFORCEMENT BAR SHALL BE 40 TIMES OF BAR DIAMETER.
 7. CONCRETE COVER TO REINFORCEMENT SHALL BE 75mm.
 8. CONSTRUCTION JOINT SHOULD BE FORMED BETWEEN EXISTING AND PROPOSED R. C. STRUCTURE.
 9. E. J. SHOULD BE PROVIDED AROUND THE PROPOSED R. C. PAVING.
 10. FORMATION SHOULD BE INSPECTED AND AGREED BY THE ENGINEER ON SITE.
 11. THIS DRAWING SHOWS THE PRELIMINARY DESIGN OF THE PROPOSED WORKS WHICH WILL BE SUBJECT TO REVIEW AND CHANGE AT DETAILED DESIGN STAGE.

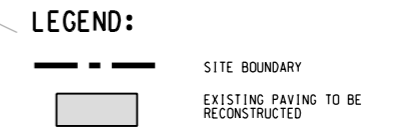

AECOM

PROJECT
LEI YUE MUN WATERFRONT ENHANCEMENT PROJECT - ENVIRONMENTAL AND TRAFFIC IMPACT ASSESSMENT STUDIES - INVESTIGATION

CLIENT
 土木工程拓展署
 Civil Engineering and Development Department

CONSULTANT
 AECOM Asia Company Ltd.
 www.aecom.com

SUB-CONSULTANTS
 分判工程師/顧問公司

ISSUE/REVISION

NO.	DATE	DESCRIPTION	CHK.

STATUS
 預覽

SCALE
 A1 AS SHOWN

DIMENSION UNIT
 MILLIMETRES

KEY PLAN A1 1:10000

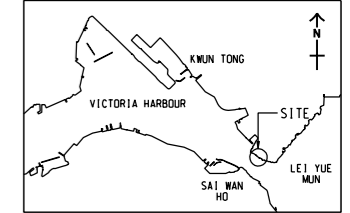

PROJECT NO.
60494885

AGREEMENT NO.

SHEET TITLE
IMPROVEMENT WORKS AT LOOKOUT POINT 3

SHEET NUMBER
60494885/EIA/APPENDIX 2.8

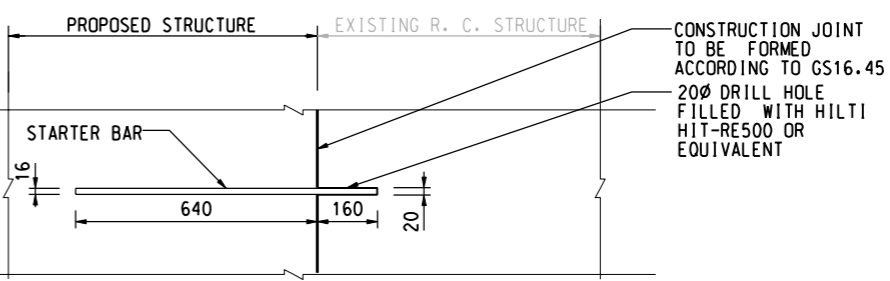
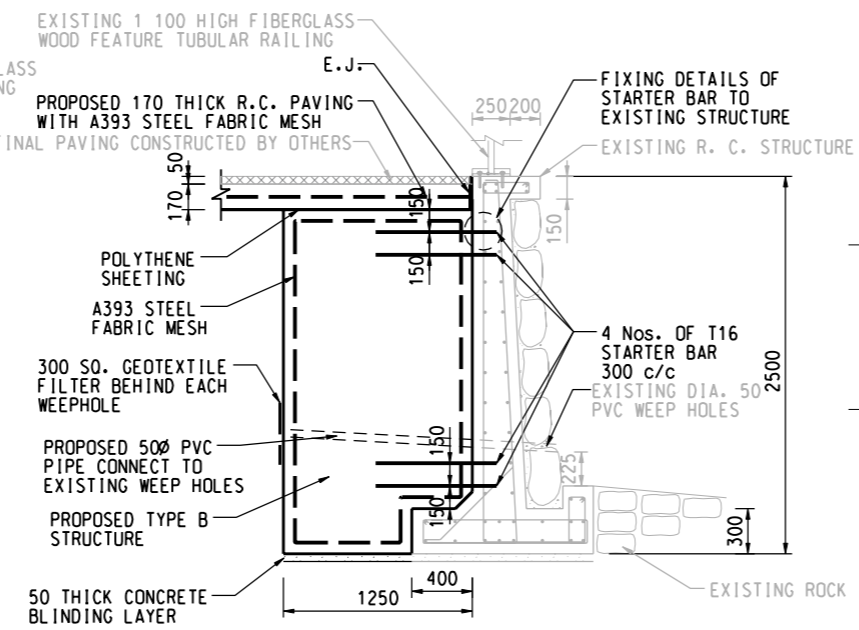
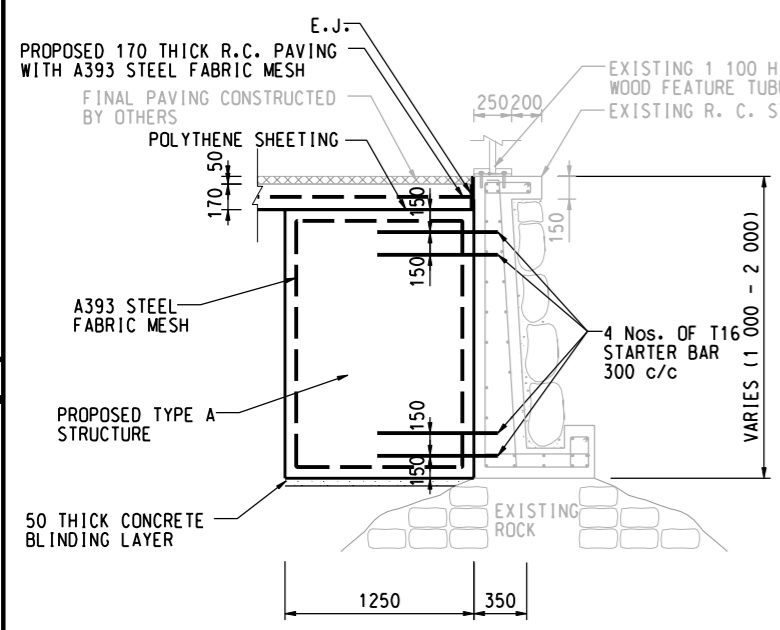

This drawing has been prepared for the use of AECOM's client. It may not be used, modified, reproduced or relied upon by third parties, except as agreed by AECOM or as required by law. AECOM accepts no responsibility, and denies any liability whatsoever, for any party that uses or relies on this drawing without AECOM's express written consent. Do not scale this document. All measurements must be obtained from the stated dimensions.